



VISHAY INTERTECHNOLOGY, INC.

INTERACTIVE

data book

LARGE AND SCREW TERMINAL ALUMINUM CAPACITORS

VISHAY

VSD-DB0078-0810

Notes:

1. To navigate:
 - a) Click on the Vishay logo on any datasheet to go to the Contents page for that section. Click on the Vishay logo on any Contents page to go to the main Table of Contents page.
 - b) Click on the products within the Table of Contents to go directly to the datasheet.
 - c) Use the scroll or page up/page down functions.
 - d) Use the Adobe® Acrobat® page function in the browser bar.
2. To search the text of the catalog use the Adobe® Acrobat® search function.



VISHAY INTERTECHNOLOGY, INC.



DATA BOOK

LARGE AND SCREW TERMINAL ALUMINUM CAPACITORS

SEMICONDUCTORS

RECTIFIERS

Schottky (single, dual)
 Standard, Fast, and Ultra-Fast Recovery
 (single, dual)
 Bridge
 Superrectifier®
 Sinterglass Avalanche Diodes

HIGH-POWER DIODES AND THYRISTORS

High-Power Fast-Recovery Diodes
 Phase-Control Thyristors
 Fast Thyristors

SMALL-SIGNAL DIODES

Schottky and Switching (single, dual)
 Tuner/Capacitance (single, dual)
 Bandswitching
 PIN

ZENER AND SUPPRESSOR DIODES

Zener (single, dual)
 TVS (TRANSZORB®, Automotive, ESD, Arrays)

FETs

Low-Voltage TrenchFET® Power MOSFETs
 High-Voltage TrenchFET® Power MOSFETs
 High-Voltage Planar MOSFETs
 JFETs

OPTOELECTRONICS

IR Emitters and Detectors,
 and IR Receiver Modules
 Optocouplers and Solid-State Relays
 Optical Sensors
 LEDs and 7-Segment Displays
 Infrared Data Transceiver Modules
 Custom Products

ICs

Power ICs
 Analog Switches
 RF Transmitter and Receiver Modules
 ICs for Optoelectronics

MODULES

Power Modules (contain power diodes,
 thyristors, MOSFETs, IGBTs)
 DC/DC Converters

PASSIVE COMPONENTS

RESISTIVE PRODUCTS

Foil Resistors
 Film Resistors
 Metal Film Resistors
 Thin Film Resistors
 Thick Film Resistors
 Metal Oxide Film Resistors
 Carbon Film Resistors
 Wirewound Resistors
 Power Metal Strip® Resistors
 Chip Fuses
 Variable Resistors
 Cermet Variable Resistors
 Wirewound Variable Resistors
 Conductive Plastic Variable Resistors
 Networks/Arrays
 Non-Linear Resistors
 NTC Thermistors
 PTC Thermistors
 Varistors

MAGNETICS

Inductors
 Transformers

CAPACITORS

Tantalum Capacitors
 Molded Chip Tantalum Capacitors
 Coated Chip Tantalum Capacitors
 Solid Through-Hole Tantalum Capacitors
 Wet Tantalum Capacitors
 Ceramic Capacitors
 Multilayer Chip Capacitors
 Disc Capacitors
 Film Capacitors
 Power Capacitors
 Heavy-Current Capacitors
 Aluminum Capacitors
 Silicon RF Capacitors

STRAIN GAGE TRANSDUCERS AND STRESS ANALYSIS SYSTEMS

PhotoStress®
 Strain Gages
 Load Cells
 Force Transducers
 Instruments
 Weighing Systems
 Specialized Strain Gage Systems

Large and Screw Terminal Aluminum Capacitors

**Vishay BCcomponents
Austria GmbH**
Ebentaler Strasse 140
A-9021 Klagenfurt
Austria
Phone: +43 463 3834 0
Fax: +43 463 3834 303
www.vishay.com

**Vishay BCcomponents
Nederland B.V.**
Ceintuurbaan 15
NL-8022 AW Zwolle
Netherlands
Phone: +31 38 4575 111
Fax: +31 38 4575 462
www.vishay.com

**Vishay Electronic
GmbH**
Geheimrat-Rosenthal-Strasse 100
D-95100 Selb
Germany
Phone: +49 9287 710
Fax: +49 9287 70435
www.vishay.com

DISCLAIMER

All product specifications and data are subject to change without notice.

Vishay Intertechnology, Inc., its affiliates, agents, and employees, and all persons acting on its or their behalf (collectively, "Vishay"), disclaim any and all liability for any errors, inaccuracies or incompleteness contained herein or in any other disclosure relating to any product.

Vishay disclaims any and all liability arising out of the use or application of any product described herein or of any information provided herein to the maximum extent permitted by law. The product specifications do not expand or otherwise modify Vishay's terms and conditions of purchase, including but not limited to the warranty expressed therein, which apply to these products.

No license, express or implied, by estoppel or otherwise, to any intellectual property rights is granted by this document or by any conduct of Vishay.

The products shown herein are not designed for use in medical, life-saving, or life-sustaining applications unless otherwise expressly indicated. Customers using or selling Vishay products not expressly indicated for use in such applications do so entirely at their own risk and agree to fully indemnify Vishay for any damages arising or resulting from such use or sale. Please contact authorized Vishay personnel to obtain written terms and conditions regarding products designed for such applications.

Product names and markings noted herein may be trademarks of their respective owners.



Large and Screw Terminal Aluminum Capacitors

Alphabetical Index	2
Replacement Table	4
Selection Chart.....	5

VISHAY BCcomponents

Introduction	8	
Product Safety	24	
Tests and Requirements	26	
Product Coding	33	
Quality Flowchart	35	
093 PMG-SI	Power Miniaturized General Purpose Snap-In, 85 °C	36
156 PUM-SI	Power Ultra Miniature Snap-In, Low Voltage, 85 °C	41
157 PUM-SI	Power Ultra Miniature Snap-In, High Voltage, 85 °C	47
197 PGP-SI	Power General Purpose Snap-In, 85 °C	55
056/057 PSM-SI	Power Standard Miniature Snap-In, 85 °C	62
198 PHR-SI	Power High Ripple Current Snap-In, High Voltage, 85 °C	72
094 PME-SI	Power Miniaturized Economy Long Life Snap-In, 105 °C.....	78
090 PUL-SI	Power Ultra Long Life Snap-In, 105 °C	85
158 PUL-SI	Power Ultra Long Life Snap-In, 105 °C	91
159 PUL-SI	Power Ultra Long Life Snap-In, 105 °C	99
199 PEL-SI	Power Economy Long Life Snap-In, 105 °C	106
058/059 PLL-SI	Power Long Life Snap-In, 105 °C	113
Mounting Accessories	123	
050/052 PED-PW	Power Eurodin Printed Wiring, 85 °C	126
051/053 PEC-PW	Power Economic Printed Wiring, 85 °C	136
095 PLL-4TSI	Power Long Life 4-Terminal Snap-In, 85 °C	145
096 PLL-4TSI	Power Long Life 4-Terminal Snap-In, 85 °C	151
162/163 PLL-PW	Power Long Life Printed Wiring, 105 °C	157
500 PGP-ST	Power General Purpose Screw Terminals, 85 °C	164
101/102 PHR-ST	Power High Ripple Current Screw Terminals, 85 °C	168
106 PED-ST	Power Eurodin Screw Terminals, 85 °C	178
104 PHL-ST	Power High Ripple Current Long Life Screw Terminals, 105 °C	183

VISHAY ROEDERSTEIN

Introduction	192	
EYN	Snap-In, 85 °C	206
EYH	Snap-In, 105 °C	214
EYC	Snap-In, Long Life, 105 °C	222
EYD	Solder Pin, 85 °C	230
EYK	Solder Lug, 85 °C	236
EYV	Solder Pin, 85 °C	240
EY	Solder Lug, 85 °C	246
EYZ	Solder Pin, 105 °C	250

VISHAY SPRAGUE

80D	Snap-In, 85 °C	258
82D	Snap-In, General Purpose, 85 °C	262
82DA	Snap-In, General Purpose, 85 °C	267
81D	Snap-In, 105 °C	270
81DA	Snap-In, 105 °C	274
36DY	Screw Terminals, General Purpose, 85 °C	277
36D, 36DE, 36DX.....	Screw Terminals, Powerlytic®, 85 °C	283
36DA	Screw Terminals, 85 °C/95 °C.....	288

E-Series Values	Standard Series Values in a Decade for Resistance and Capacitances.....	294
-----------------------	---	-----

BRAND	CODE	DATA BOOK	CODE
BCcomponents	BC	SMD . Radial . Axial (VSE-DB0111-0810)	S . R . A
Roederstein	RO	Large and Screw Terminal (VSE-DB0078-0810)	L & S
Sprague	SP		

PRODUCT DESIGNATION	DESCRIPTION	PAGE	BRAND	DATA BOOK
013 RLC	Radial Low Leakage Current, 85 °C	95	BC	S . R . A
021 ASM	Axial Standard Miniature, 85 °C	172	BC	S . R . A
030/031 AS	Axial Standard, 85 °C	179	BC	S . R . A
036 RSP	Radial Semi Professional, 85 °C	101	BC	S . R . A
038 RSU	Radial Standard Ultra Miniature, 85 °C	89	BC	S . R . A
041 - 043 ASH	Axial Standard, High Voltage, 85 °C	187	BC	S . R . A
042/043 AHH-ELB	Axial High Temp. High Voltage for Electronic Lighting Ballast, 105 °C	200	BC	S . R . A
042/043 AMH-ELB	Axial Miniature High Voltage for Electronic Lighting Ballast, 85 °C	195	BC	S . R . A
048 RML	Radial Miniature Long Life, 105 °C	118	BC	S . R . A
050/052 PED-PW	Power Eurodin Printed Wiring, 85 °C	126	BC	L & S
051/053 PEC-PW	Power Economic Printed Wiring, 85 °C	136	BC	L & S
056/057 PSM-SI	Power Standard Miniature Snap-In, 85 °C	62	BC	L & S
058/059 PLL-SI	Power Long Life Snap-In, 105 °C	113	BC	L & S
090 PUL-SI	Power Ultra Long Life Snap-In, 105 °C	85	BC	L & S
093 PMG-SI	Power Miniaturized General Purpose Snap-In, 85 °C	36	BC	L & S
094 PME-SI	Power Miniaturized Economy Long Life Snap-In, 105 °C	78	BC	L & S
095 PLL-4TSI	Power Long Life 4-Terminal Snap-In, 85 °C	145	BC	L & S
096 PLL-4TSI	Power Long Life 4-Terminal Snap-In, 85 °C	151	BC	L & S
097 RLP 7	Radial Low Profile, 7 mm, 85 °C	85	BC	S . R . A
101/102 PHR-ST	Power High Ripple Current Screw Terminals, 85 °C	168	BC	L & S
104 PHL-ST	Power High Ripple Current Long Life Screw Terminals, 105 °C	183	BC	L & S
106 PED-ST	Power Eurodin Screw Terminals, 85 °C	178	BC	L & S
116 RLL	Radial Long Life, 105 °C	113	BC	S . R . A
117 ASD	Axial Smallest Diameter, 85 °C	168	BC	S . R . A
118 AHT	Axial, High Temperature, 125 °C	224	BC	S . R . A
119 AHT-DIN	Axial High Temperature, DIN Based, 125 °C	234	BC	S . R . A
120 ATC	Axial High temperature, High Ripple Current, 125 °C	244	BC	S . R . A
123 SAL-A	Axial, Solid, 125 °C	251	BC	S . R . A
128 SAL-RPM	Solid Aluminum Radial Pearl Miniature, 125 °C	153	BC	S . R . A
132/133 ALL-DIN	Axial Long-Life, DIN Based, 85 °C	216	BC	S . R . A
134 RLP 5	Radial Low Profile, 5 mm, 85 °C	81	BC	S . R . A
136 RVI	Radial Very Low Impedance, 105 °C	130	BC	S . R . A
138 AML	Axial Miniature Long-Life, 105 °C	205	BC	S . R . A
140 CRH	SMD Long Life, High Temperature, 125 °C	66	BC	S . R . A
140 RTM	Radial High Temperature Miniature, 125 °C	147	BC	S . R . A
148 RUS	Ultra High CV per Volume, Semi-Professional, 105 °C	106	BC	S . R . A
150 CRZ	SMD, Long Life , Low Impedance, 105 °C	58	BC	S . R . A
150 RMI	Radial Miniature, Low Impedance, 105 °C	140	BC	S . R . A
152 RMH	Radial Miniature, High Voltage, 105 °C	125	BC	S . R . A
153 CRV	SMD Long Life, 105 °C	50	BC	S . R . A
156 PUM-SI	Power Ultra Miniature Snap-In, Low Voltage, 85 °C	41	BC	L & S
157 PUM-SI	Power Ultra Miniature Snap-In, High Voltage, 85 °C	47	BC	L & S
158 PUL-SI	Power Ultra Long Life Snap-In, 105 °C	91	BC	L & S
159 PUL-SI	Power Ultra Long Life Snap-In, 105 °C	99	BC	L & S
162/163 PLL-PW	Power Long Life Printed Wiring, 105 °C	157	BC	L & S
175 TMP	SMD High Temperature Solid Electrolyte, 175 °C	74	BC	S . R . A
196 DLC	Double Layer Capacitors, 70 °C	162	BC	S . R . A
197 PGP-SI	Power General Purpose Snap-In, 85 °C	55	BC	L & S
198 PHR-SI	Power High Ripple Current Snap-In, High Voltage, 85 °C	72	BC	L & S
199 PEL-SI	Power Economy Long Life Snap-In, 105 °C	106	BC	L & S
30D	Axial General Purpose Miniature, 105 °C	485	SP	S . R . A



PRODUCT DESIGNATION	DESCRIPTION	PAGE	BRAND	DATA BOOK
36D, 36DE, 36DX	Screw Terminals, Powerlytic®, 85 °C	283	SP	L & S
36DA	Screw Terminals, 85 °C/95 °C	288	SP	L & S
36DY	Screw Terminals, General Purpose, 85 °C	277	SP	L & S
39D	Axial, Powerlytic®, 85 °C	452	SP	S . R . A
500D	Axial, General Purpose Miniature, 85 °C	462	SP	S . R . A
500 PGP-ST	Power General Purpose Screw Terminals, 85 °C	164	BC	L & S
510D	Radial, Miniature, Low Leakage, 105 °C	430	SP	S . R . A
510DX	Radial, Miniature, 125 °C	444	SP	S . R . A
511D	Radial, General Purpose, Miniature, 105 °C	402	SP	S . R . A
515D	Radial, Miniature, 85 °C	394	SP	S . R . A
516D	Axial, Miniature, 85 °C	471	SP	S . R . A
517D	Radial, General Purpose, Miniature, 105 °C	407	SP	S . R . A
53D	Axial, General Purpose, 85 °C	459	SP	S . R . A
600D	Axial, Miniature, High Reliability, 125 °C	491	SP	S . R . A
601D	Axial, Miniature, 105 °C	481	SP	S . R . A
604D	Axial, 4-Terminal, 105 °C	483	SP	S . R . A
610D	Axial, Miniature, Non-Polar, 125 °C	497	SP	S . R . A
630D	Axial, Miniature, 125 °C	489	SP	S . R . A
672D	Radial, Miniature, Low Impedance, 105 °C	424	SP	S . R . A
678D	Radial, Miniature, 105 °C	414	SP	S . R . A
757D	Radial, Miniature, Long Life, 105 °C	418	SP	S . R . A
80D	Snap-In, 85 °C	258	SP	L & S
81D	Snap-In, 105 °C	270	SP	L & S
81DA	Snap-In, 105 °C	274	SP	L & S
82D	Snap-In, General Purpose, 85 °C	262	SP	L & S
82DA	Snap-In, General Purpose, 85 °C	267	SP	L & S
94SA	Radial, Miniaturized, Organic Electrolyte, 105 °C	379	SP	S . R . A
94SC	Radial, Standard, Organic Electrolyte, 105 °C	376	SP	S . R . A
94SH	Radial, Long Life, Organic Electrolyte, 105 °C	384	SP	S . R . A
94SL	Radial, Low Profile, 5 mm, Organic Electrolyte, 105 °C	381	SP	S . R . A
94SP	Radial, Low ESR, Organic Electrolyte, 105 °C	390	SP	S . R . A
94SS	Radial, Miniaturized, Organic Electrolyte, 105 °C	387	SP	S . R . A
94SVP	SMD, Organic Electrolyte, 105 °C	361	SP	S . R . A
94SVPD	SMD, Organic Electrolyte, 125 °C	364	SP	S . R . A
ECA	SMD, Standard, 85 °C	278	RO	S . R . A
ECL	SMD, Low Impedance, 105 °C	287	RO	S . R . A
ECV	SMD, Standard, 105 °C	283	RO	S . R . A
EKA	Radial, Miniature, 85 °C	291	RO	S . R . A
EKB	Radial, Miniature, 105 °C	298	RO	S . R . A
EKE	Radial, Low Impedance, 105 °C	310	RO	S . R . A
EKI	Radial, Low Leakage, 105 °C	306	RO	S . R . A
EKL	Radial, High Temperature, 125 °C	326	RO	S . R . A
EKSU	Radial, Non Polarized, 105 °C	332	RO	S . R . A
EKV	Radial, Lighting Ballast, 105 °C	322	RO	S . R . A
EKX	Radial, Extra Low Impedance, 105 °C	317	RO	S . R . A
EY	Solder Lug, 85 °C	246	RO	L & S
EYC	Snap-In Long Life, 105 °C	222	RO	L & S
EYD	Solder Pin, 85 °C	230	RO	L & S
EYH	Snap-In, 105 °C	214	RO	L & S
EYK	Solder Lug, 85 °C	236	RO	L & S
EYN	Snap-In, 85 °C	206	RO	L & S
EYV	Solder Pin, 85 °C	240	RO	L & S
EYZ	Solder Lug, 85 °C	250	RO	L & S
TE	Axial, Little-Lytic®, 105 °C	477	SP	S . R . A
TVA ATOM®	Axial, Standard Miniature, 85 °C	448	SP	S . R . A
U673D and U674D	Radial, 105 °C	432	SP	S . R . A

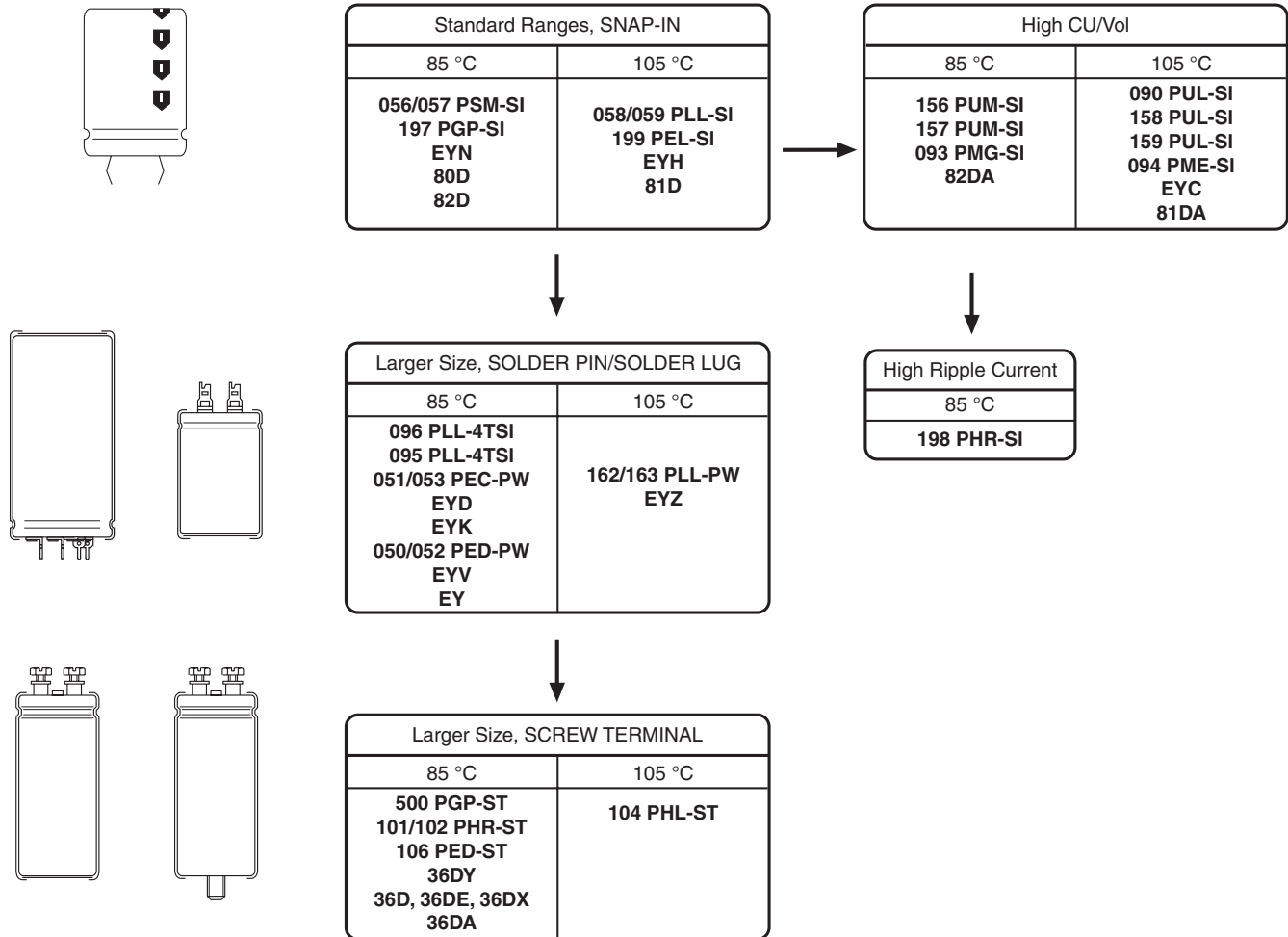
Replacement Table

Vishay



REPLACEMENT SERIES TABLE				
WITHDRAWN SERIES		DESIGN	REMARK	REPLACEMENT SERIES
ORDERING CODE	FORMER PARTNUMBER			
-	2222 054	Snap-In	General purpose, 85 °C	056/057 PSM-SI
-	2222 055	Snap-In	General purpose, 85 °C	056/057 PSM-SI
-	2222 086	Screw Terminal	General purpose, 85 °C	101/102 PHR-ST
-	2222 087	Screw Terminal	General purpose, 85 °C	101/102 PHR-ST
-	2222 088	Screw Terminal	General purpose, 85 °C	101/102 PHR-ST
-	2222 089	Screw Terminal	General purpose, 85 °C	101/102 PHR-ST
-	2222 111	Screw Terminal	General purpose, 85 °C	101/102 PHR-ST
-	2222 112	Screw Terminal	General purpose, 85 °C	101/102 PHR-ST
-	2222 114	Screw Terminal	Long Life, 85 °C	106 PED-ST
-	2222 115	Screw Terminal	Long Life, 85 °C	101/102 PHR-ST
-	2222 154	Screw Terminal	Long Life, 85 °C	101/102 PHR-ST
-	2222 155	Screw Terminal	Long Life, 85 °C	101/102 PHR-ST
-	2222 166	4 Terminal Snap-In	Long Life, 85 °C	Contact sales
-	2222 167	4 Terminal Snap-In	Long Life, 85 °C	Contact sales
-	2222 168	4 Terminal Snap-In	Long Life, 105 °C	Contact sales
-	2222 169	4 Terminal Snap-In	Long Life, 105 °C	Contact sales
-	3148.....	Screw Terminal	High Ripple ≤ 75 V, 105 °C	Contact sales
-	3173.....	Screw Terminal	Long Life, 85 °C	101/102 PHR-ST
-	3186.....	Screw Terminal	General purpose, 85 °C	101/102 PHR-ST
-	3188.....	Screw Terminal	General purpose, 85 °C	101/102 PHR-ST
-	3191.....	Screw Terminal	General purpose, 85 °C	101/102 PHR-ST
-	3198.....	Screw Terminal	General purpose, 105 °C	104 PHL-ST
-	3199.....	Screw Terminal	General purpose, 85 °C	101/102 PHR-ST
-	3500.....	Screw Terminal	Motor Start	No replacement
MALTEYE.....	EYE.....	Screw Terminal	General purpose, 85 °C	101/102 PHR-ST
MALTEYM.....	EYM.....	Screw Terminal	General purpose, 85 °C	101/102 PHR-ST
MALTEYP.....	EYP.....	Screw Terminal	General purpose, 85 °C	101/102 PHR-ST
MALIEYS.....	EYS.....	Snap-In	General purpose ≤ 100 V, 105 °C	EYH
MALIEYS.....	EYS.....	Snap-In	General purpose > 100 V, 85 °C	093 PMG-SI

Large and Screw Terminal Series







Vishay BCcomponents

Contents

Introduction	8
Product Safety	24
Tests and Requirements	26
Product Coding	33
Quality Flowchart	35
093 PMG-SI	36
156 PUM-SI	41
157 PUM-SI	47
197 PGP-SI	55
056/057 PSM-SI	62
198 PHR-SI	72
094 PME-SI	78
090 PUL-SI	85
158 PUL-SI	91
159 PUL-SI	99
199 PEL-SI	106
058/059 PLL-SI	113
Mounting Accessories	123
050/052 PED-PW	126
051/053 PEC-PW	136
095 PLL-4TSI	145
096 PLL-4TSI	151
162/163 PLL-PW.....	157
500 PGP-ST	164
101/102 PHR-ST	168
106 PED-ST	178
104 PHL-ST	183

Aluminum Capacitors

TRANSLATION OF TECHNICAL TERMS		
SOME IMPORTANT TERMS	DES TERMES IMPORTANTES	EINIGE WICHTIGE BEGRIFFE
Ambient temperature (T_{amb})	température ambiante	Umgebungstemperatur
Assessment level	niveau d'assurance	Gütebestätigungsstufe
Axial terminations	sorties axiales	axiale Anschlußdrähte
Capacitance	capacité	Kapazität
Charge	charge	laden
Climatic category	catégorie climatique	Klimakategorie
Dimensions	dimensions	Maße
Discharge	décharge	entladen
Dissipation factor ($\tan \delta$)	tangente de l'angle de pertes	Verlustfaktor
Endurance	endurance	Dauerspannungsprüfung
Equivalent series resistance (ESR)	résistance série équivalente	äquivalenter Serienwiderstand
Equivalent series inductance (ESL)	inductance série équivalente	äquivalente Serieninduktivität
Failure rate	taux de fiabilité	Ausfallrate
Frequency (f)	fréquence	Frequenz
General purpose grade	usage général	allgemeine Anforderungen
Impedance (Z)	impédance	Scheinwiderstand, Impedanz
Leadless	sans fils	unbedrahtet
Leakage current (I_l)	courant de fuite	Reststrom
Long life grade	longue durée de vie	erhöhte Anforderungen
Method	méthode	Verfahren
Mounting	montage	Montage
No visible damage	aucun dommage	keine sichtbaren Schäden
Open circuit	circuit ouvert	Unterbrechung
Mounting hole diagram	dessin de montage	Bohrungsraster
Rated capacitance (C_R)	capacité nominale	Nennkapazität
Rated voltage (U_R)	tension nominale	Nennspannung
Recovery	reprise	Nachbehandlung
Forming voltage (U_F)	tension de formation	Formierspannung
Requirements	exigences	Anforderungen
Reverse voltage (U_{rev})	tension inverse	Umpolspannung
Ripple current (I_R)	courant ondulé	überlagerter Wechselstrom
Short circuit	court-circuit	Kurzschluß
Surface mounting device (SMD)	composant pour montage en surface	oberflächenmontierbares Bauelement
Surge voltage (U_S)	surtension	Spitzenspannung
Terminal pitch	distance entre les connections	Rastermaß
Terminations	sorties	Anschlüsse
Useful life	durée de vie	Brauchbarkeitsdauer
Visual examination	examen visuel	Sichtkontrolle

CAPACITOR PRINCIPLES

The essential property of a capacitor is to store electrical charge. The amount of electrical charge (Q) in the capacitor (C) is proportional to the applied voltage (U). The relationship of these parameters is:

$$Q = C \times U$$

where:

- Q = charge in coulombs (C)
- C = capacitance in farads (F)
- U = voltage in volts (V)

The value of capacitance is directly proportional to the (anode) surface area and inversely proportional to the thickness of the dielectric layer, thus:

$$C = \epsilon_0 \times \epsilon_r \times \frac{A}{d}$$

where:

- ϵ_0 = absolute permittivity (8.85×10^{-12} F/m)
- ϵ_r = relative dielectric constant (dimensionless)
- A = surface area (m²)
- d = thickness of the dielectric (oxide layer in aluminum capacitors) (m).

ENERGY CONTENT OF A CAPACITOR

The energy content of a capacitor is given by:

$$W_E = \frac{1}{2} \times (C \times U^2)$$

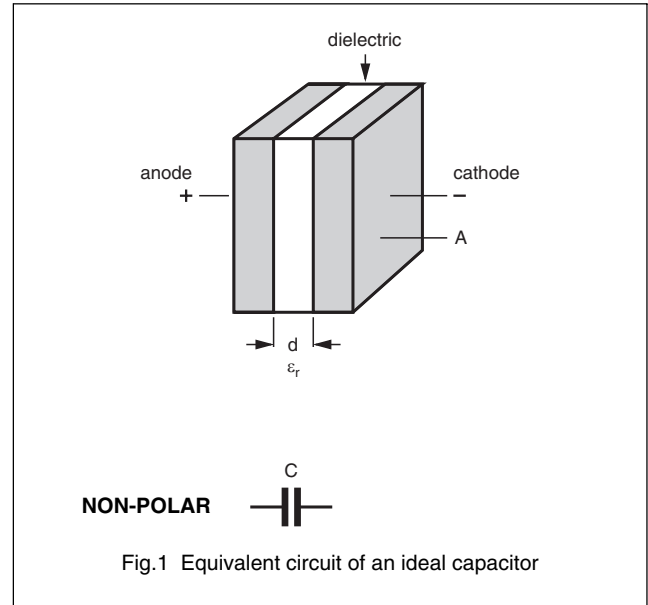


Fig.1 Equivalent circuit of an ideal capacitor

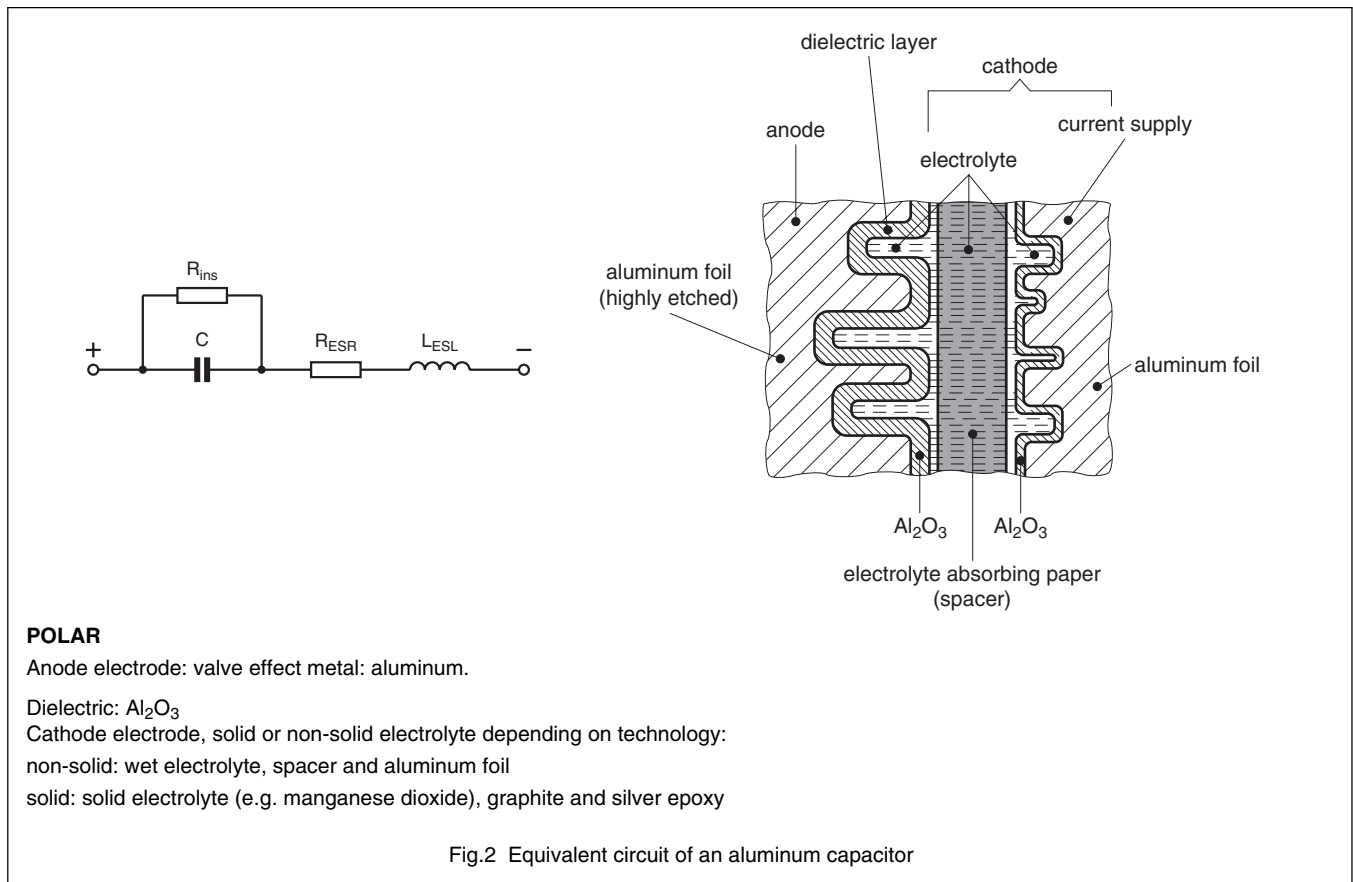


Fig.2 Equivalent circuit of an aluminum capacitor

POLAR

Anode electrode: valve effect metal: aluminum.

Dielectric: Al₂O₃

Cathode electrode, solid or non-solid electrolyte depending on technology:

non-solid: wet electrolyte, spacer and aluminum foil

solid: solid electrolyte (e.g. manganese dioxide), graphite and silver epoxy

ELECTRICAL BEHAVIOR

Characteristics of aluminum capacitors vary with temperature, time and applied voltage.

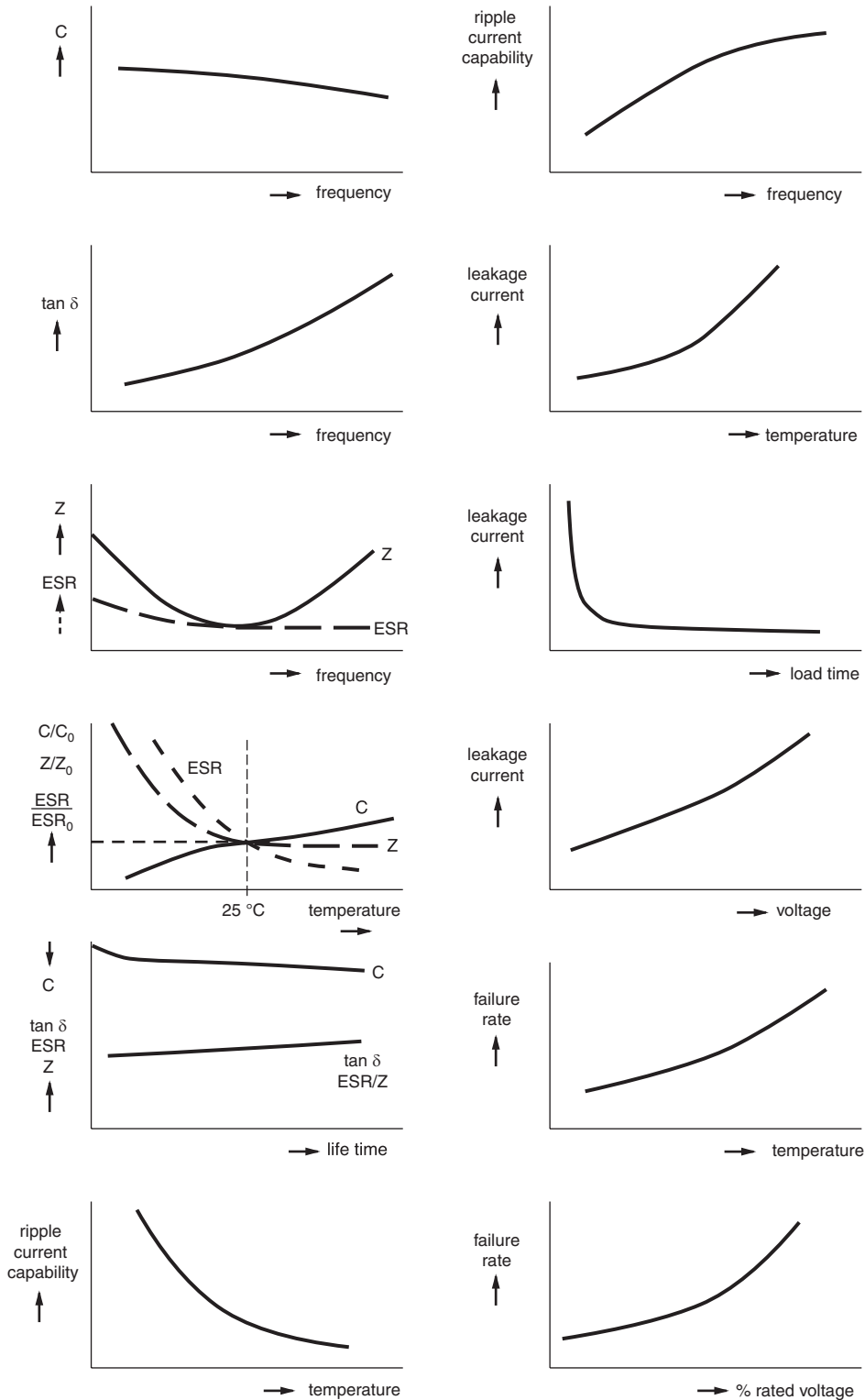


Fig.3 Typical variation of electrical parameters as a function of frequency, ambient temperature, voltage and time

CONSTRUCTION

Examples

Wound cell, consisting of:

- Aluminum foil anode with aluminum oxide dielectric
- Paper spacer impregnated with electrolyte
- Aluminum foil cathode

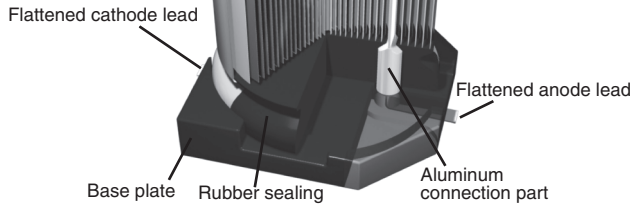


Fig.4 Surface Mount Device (vertical style)

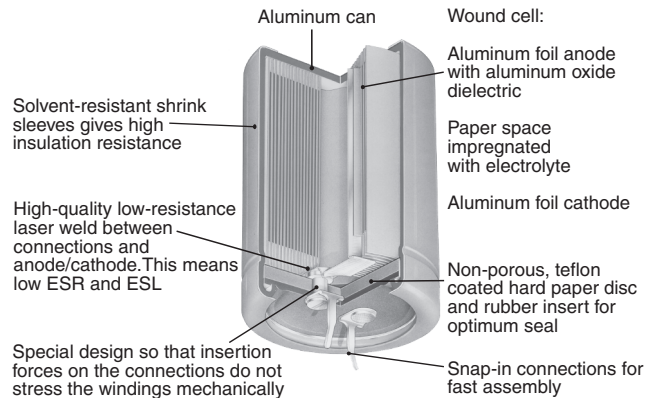


Fig.7 Large Aluminum, snap-in

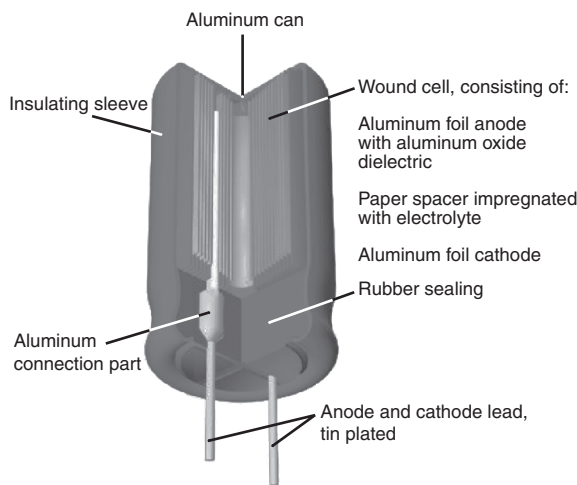


Fig.5 Radial Aluminum

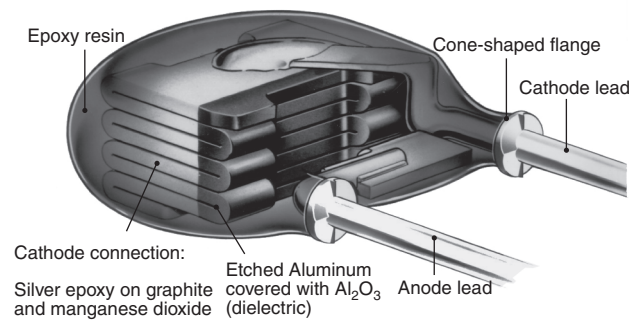


Fig.8 Solid Aluminum (SAL), radial

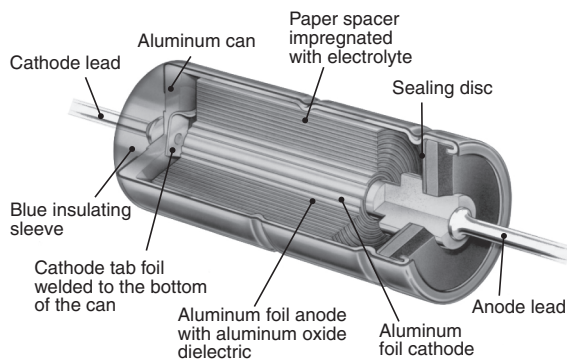


Fig.6 Axial Aluminum

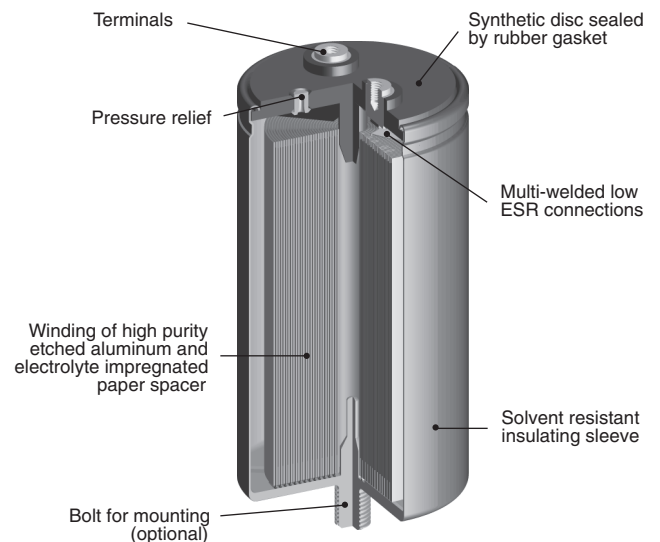


Fig.9 Large Aluminum, screw terminal

DEFINITIONS OF ELECTRICAL PARAMETERS

Sequence of measurement for tests are in accordance with "IEC 60384-4":

1. Leakage current (I_L)
2. Capacitance (C_R)
3. Dissipation factor ($\tan \delta$ or ESR)
4. Impedance (Z)

CAPACITANCE

AC CAPACITANCE OF AN ALUMINUM CAPACITOR

The capacitance of an equivalent circuit, having capacitance, resistance and inductance in series, measured with alternating current of approximately sinusoidal waveform at a specified frequency; refer to Fig.10.

Standard measuring frequencies for aluminum capacitors are 100 Hz or 120 Hz



Fig.10 AC equivalent circuit of an aluminum capacitor

DC CAPACITANCE OF AN ALUMINUM CAPACITOR (FOR TIMING CIRCUITS)

DC capacitance is given by the amount of charge which is stored in the capacitor at the rated voltage (U_R).

DC capacitance is measured by a single discharge of the capacitor under defined conditions. Measuring procedures are described in "DIN 41328, sheet 4" (withdrawn).

At any given time, the DC capacitance is higher than the AC capacitance.

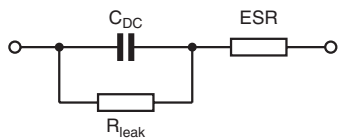


Fig.11 DC equivalent circuit of an aluminum capacitor

RATED CAPACITANCE (C_R)

The capacitance value for which the capacitor has been designed and which is usually indicated upon it.

Preferred values of rated capacitance and their decimal multiples are preferably chosen from the E3 series of "IEC Publication 60063".

TOLERANCE ON RATED CAPACITANCE

Preferred values of tolerances on rated capacitance

- 20/+ 20 %	- 10/+ 50 %	- 10/+ 30 %	- 10/+ 10 %
M	T	Q	K

These values depend on the relevant series.

VOLTAGE

RATED VOLTAGE (U_R)

The maximum DC voltage, or peak value of pulse voltage which may be applied continuously to a capacitor at any temperature between the lower category temperature and the rated temperature.

CATEGORY VOLTAGE (U_C)

The maximum voltage which may be applied continuously to a capacitor at its upper category temperature.

TEMPERATURE DERATED VOLTAGE

The temperature derated voltage is the maximum voltage that may be applied continuously to a capacitor, for any temperature between the rated temperature and the upper category temperature.

RIPPLE VOLTAGE (U_{RPL})

An alternating voltage may be applied, provided that the peak voltage resulting from the alternating voltage, when superimposed on the DC voltage, does not exceed the value of rated DC voltage or fall under 0 V and that the ripple current is not exceeded.

REVERSE VOLTAGE (U_{REV})

The maximum voltage applied in the reverse polarity direction to the capacitor terminations.

SURGE VOLTAGE (U_S)

The maximum instantaneous voltage which may be applied to the terminations of the capacitor for a specified time at any temperature within the category temperature range.

TEMPERATURE

CATEGORY TEMPERATURE RANGE

The range of ambient temperatures for which the capacitor has been designed to operate continuously: this is defined by the temperature limits of the appropriate category.

RATED TEMPERATURE

The maximum ambient temperature at which the rated voltage may be continuously applied.

MINIMUM STORAGE TEMPERATURE

The minimum permissible ambient temperature which the capacitor shall withstand in the non-operating condition, without damage.

RESISTANCE/REACTANCE

EQUIVALENT SERIES RESISTANCE (ESR)

The ESR of an equivalent circuit having capacitance, inductance and resistance in series measured with alternating current of approximately sinusoidal waveform at a specified frequency; refer to Fig.10.

**EQUIVALENT SERIES INDUCTANCE (ESL)**

The ESL of an equivalent circuit having capacitance, resistance and inductance in series measured with alternating current of approximately sinusoidal waveform at a specified frequency; refer to Fig.10.

DISSIPATION FACTOR (TANGENT OF LOSS ANGLE; $\tan \delta$)

The power loss of the capacitor divided by the reactive power of the capacitor at a sinusoidal voltage of specified frequency. The dissipation factor can be approximated by following formula:

$$\tan \delta = \text{ESR} \times 2 \pi f C$$

IMPEDANCE (Z)

The impedance (Z) of an aluminum capacitor is given by capacitance, ESR and ESL in accordance with the following equation (see Fig.12):

$$Z = \sqrt{\text{ESR}^2 + \left(2 \pi f \text{ESL} - \frac{1}{2 \pi f C}\right)^2}$$

CURRENT**LEAKAGE CURRENT (I_L)**

The DC current flowing through a capacitor when a DC voltage is applied in correct polarity. It is dependent on voltage, temperature and time.

LEAKAGE CURRENT FOR ACCEPTANCE TEST (I_{L5})

In accordance with international standards ("IEC 60384-4" and "EN130300") the leakage current (I_{L5}) **after 5 minutes** application of rated voltage at 20 °C is considered as an acceptance requirement.

The leakage current requirements for the majority of Vishay BCcomponents aluminum capacitors, are lower than specified in "IEC 60384-4" or "EN130300".

If, for example, after prolonged storage and/or storage at excessive temperature (> 40 °C), the leakage current at the first measurement does not meet the requirements, pre-conditioning shall be carried out in accordance with "EN130300 subclause 4.1".

LEAKAGE CURRENT AT DELIVERY (I_{L1} OR I_{L2})

In addition to I_{L5} , the leakage current **after 1 minute** application of rated voltage (I_{L1}) is specified in most of the detail specifications.

For some series this value is specified **after 2 minutes** (I_{L2}).

OPERATIONAL LEAKAGE CURRENT (I_{OP})

After continuous operation (1 hour or longer) the leakage current will normally decrease to less than 20 % of the 5 minute value (I_{L5}).

The operational leakage current depends on applied voltage and ambient temperature; see Tables 1 and 2.

LEAKAGE CURRENT AFTER STORAGE WITH NO VOLTAGE APPLIED (SHELF LIFE)

If non-solid aluminum capacitors are stored above room temperature for long periods of time, the oxide layer may react with the electrolyte, causing increased leakage current when switched on for the first time after storage.

Table 1

TYPICAL MULTIPLIER OF OPERATIONAL LEAKAGE CURRENT AS A FUNCTION OF AMBIENT TEMPERATURE										
SYMBOL	MULTIPLIER ⁽¹⁾									
T_{amb} (°C)	- 55	- 40	- 25	0	20	45	65	85	105	125
I_{OP}/I_L	< 0.5	0.5	0.6	0.8	1	1.5	2.5	4	7	10

Note

(1) As far as allowed for the corresponding series

Table 2

TYPICAL MULTIPLIER OF OPERATIONAL LEAKAGE CURRENT AS A FUNCTION OF APPLIED VOLTAGE										
SYMBOL	MULTIPLIER									
U/U_R	< 0.2	0.3	0.4	0.5	0.6	0.7	0.8	0.9	1.0	
I_{OP}/I_L	0.1	0.15	0.2	0.3	0.4	0.5	0.65	0.8	1	

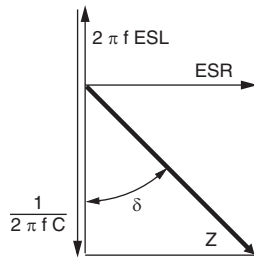


Fig.12 Vector diagram showing the AC parameters of a capacitor

RATED RIPPLE CURRENT (I_R)

Any pulsating voltage (or ripple voltage superimposed on DC bias) across a capacitor results in an alternating current through the capacitor.

Because of ohmic and dielectric losses in the capacitor, this alternating current produces an increase of temperature in the capacitor cell.

The heat generation depends on frequency and waveform of the alternating current.

The maximum RMS value of this alternating current, which is permitted to pass through the capacitor during its entire specified useful life (at defined frequency and defined ambient temperature), is called **rated ripple current** (I_R).

The rated ripple current is specified in the relevant detail specifications at 100 Hz or 120 Hz (in special cases at 100 kHz and at upper category temperature).

Usually the rated ripple current will cause a temperature increase of the capacitor's surface of approximately 3 K or 5 K (dependent on series) compared with ambient temperature. A further temperature increase of 3 K or 5 K will be found in the core of the capacitor.

This temperature rise is the result of the balance between heat generated by electric losses:

$$P = I_R^2 \text{ ESR}$$

and the heat carried off by radiation, convection and conduction:

$$P = \Delta T \times A \times \beta$$

I_R can be determined by the equation:

$$I_R = \sqrt{\frac{\Delta T \times A \times \beta}{\text{ESR}}}$$

where:

ΔT = difference of temperature between ambient and case surface (3 K to 5 K, dependent on series)

A = geometric surface area of the capacitor

β = specific heat conductivity, dependent on the size of the capacitor.

The heat, generated by ripple current, is an important factor of influence for non-solid aluminum capacitors for calculating the useful life under certain circumstances.

In the detail specifications this factor is considered in the so-called 'life-time nomograms' ('Multiplier of useful life' graph) as a ratio between actual ripple current (I_A) and rated ripple current (I_R), drawn on the vertical axis.

Care should be taken to ensure that the actual ripple current remains inside the graph at any time of the entire useful life. If this cannot be realized, it is more appropriate to choose a capacitor with a higher rated voltage or higher capacitance, than originally required by the application.

The internal losses and the resultant ripple current capability of aluminum capacitors are frequency dependent. Therefore, a relevant frequency conversion table ('Multiplier of ripple current as a function of frequency') is stated in the detail specifications. See also "CALCULATION OF USEFUL LIFE BY MEANS OF 'LIFE-TIME NOMOGRAMS'."

CALCULATION OF THE APPLICABLE RMS RIPPLE CURRENT

Non-sinusoidal ripple currents (if not accessible by direct measurement) have to be analysed into a number of sinusoidal ripple currents by means of Fourier-analysis; the vectorial sum of the currents thus found may not exceed the applicable ripple current.

For some frequently occurring waveforms, approximation formulae are stated in Fig.13 for calculating the corresponding RMS value.

WAVE FORM	RMS VALUE
	$A \sqrt{\frac{t_0}{T}}$
	$A \sqrt{\frac{t_1 + t_2}{3T}}$
	$A \sqrt{\frac{2 t_1 + 3 t_2}{3T}}$
	$A \sqrt{\frac{t_0}{2T}}$

Fig.13 Approximation formulae for RMS values of non-sinusoidal ripple currents

STORAGE

No pre-condition will be necessary for Vishay BCcomponents aluminum capacitors, when stored under standard atmospheric conditions (15 °C to 25 °C; 25 % to 75 % RH; 860 mbar to 1060 mbar) for the following periods of time:

- 3 years for non-solid 85 °C types
- 4 years for non-solid 105 °C types
- 10 years for non-solid 125 °C types
- 20 years for solid types.

After these periods, the leakage current for acceptance test shall not exceed twice the specified I_{L5} requirement.

A limited current can be applied to reduce the leakage current of long stored capacitors to normal values. The maximum allowed current when doing this at room temperature is given by the following formula:

$$I_{\max.} = \frac{\beta \times \pi}{U_r} \times \left(\left(\frac{D}{2} \right)^2 + D \times L \right)$$

In this equation, U_r is the rated voltage, D the diameter of the capacitor can and L the length of the capacitor can. When $I_{\max.}$ is in mA, D in mm and L in mm, the value for β is 1 mW/mm². During this reforming process, the rated voltage shall not be exceeded. The process has ended when the current drops below the specified leakage current.

To ensure good solderability and quality of taping, for all types and prior to mounting, the storage time shall not exceed 3 years. This means for example: 2 years storage time between manufacture and arrival at the customer, plus 1 year in customer storage.

OPERATIONAL CONDITIONS

CHARGE-DISCHARGE PROOF

This term means the capability of capacitors to withstand frequent switching operations without significant change of capacitance.

Vishay BCcomponents aluminum capacitors are charge-discharge proof in accordance with “IEC 60384-4” and “EN130300 subclause 4.20”: unless otherwise specified, 10⁶ switching operations (RC = 0.1 s) shall not cause a capacitance change of more than 10 %.

Non-frequent charging and discharging, without a series resistor, will not damage the capacitor.

If a capacitor is charged and discharged continuously several times per minute, the charge and discharge currents have to be considered as ripple currents flowing through the capacitor. The RMS value of these currents should be determined and the resultant value must not exceed the applicable limit.

ENDURANCE TEST

In “IEC 60384-4” or “EN130300” the criteria for the acceptable drift of electrical parameters after the endurance test at U_R and upper category temperature are defined.

Test duration and conditions per series are stated in the relevant detail specification.

The endurance test does not provide information about the useful life of a capacitor, as no failure percentage is defined for this test.

USEFUL LIFE

Useful life (other names: load life, life time or typical life time) is that period of time, during which a given failure percentage may occur, under well defined conditions and requirements. Useful life data are usually calculated with a confidence level of 60 %.

High quality of materials and controlled manufacturing processes provided, the useful life of non-solid aluminum capacitors is, in most cases, determined by evaporation of electrolyte through the sealing.

Figure 14 shows the principal electrical consequences of this electrolyte loss: increasing impedance and decreasing capacitance at the end of useful life, for different non-solid types.

Due to the fact that no liquid electrolyte is used in solid aluminum capacitors, the associated failure mechanism does not occur.

For non-solid aluminum capacitors the influence of temperature on useful life is approximated by the so-called ‘10 K-rule’. The ‘10 K-rule’ states that double the life time can be expected per 10 K temperature decrease; this principle is derived from the well known law of Arrhenius about acceleration of reaction processes.

The exact temperature dependence of useful life for a particular range is given in the corresponding detail specification in the ‘life-time nomogram’ (‘Multiplier of useful life’ graph in the detail specifications). Detailed performance requirements, on which the definition ‘useful life’ is based, are also stated in the relevant detail specifications.

Exceeding those requirements shall not necessarily induce a malfunction of the equipment involved. The performance requirements offer advice on the choice of components and design of the circuitry.

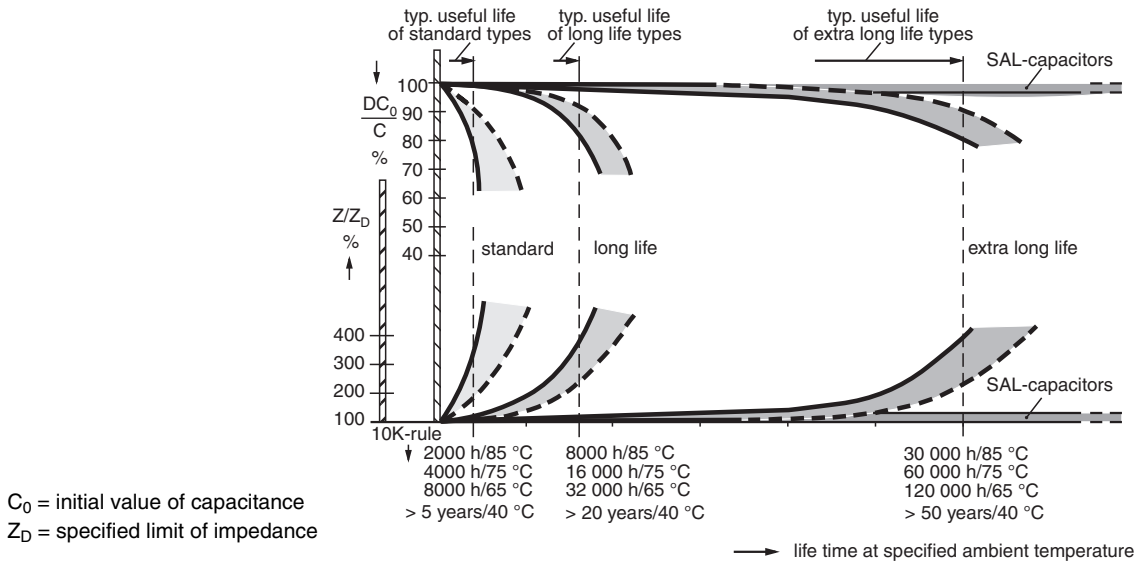


Fig.14 Principal trend of electrical parameters during useful life of different aluminum capacitors

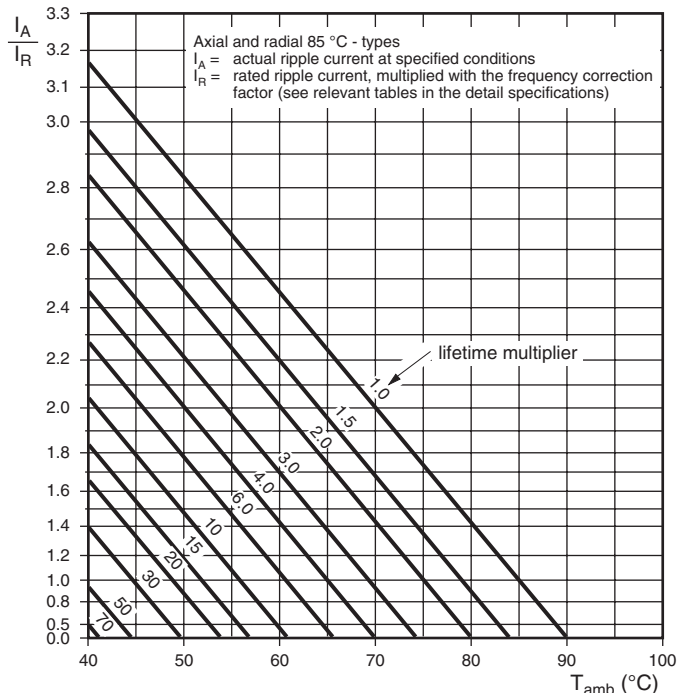
CALCULATION OF USEFUL LIFE BY MEANS OF 'LIFE-TIME NOMOGRAMS'

Based on the Arrhenius law and on experience for some decades, a nomogram is specified in the detail specification for each range, where the influence of ambient temperature and ripple current on the expected useful life is shown. Ripple currents at other frequencies than specified must be corrected using the frequency conversion tables in the relevant detail specification.

The ratio of actual ripple current to rated ripple current (I_A/I_R) is plotted on the vertical axis and the ambient temperature (T_{amb}) on the horizontal.

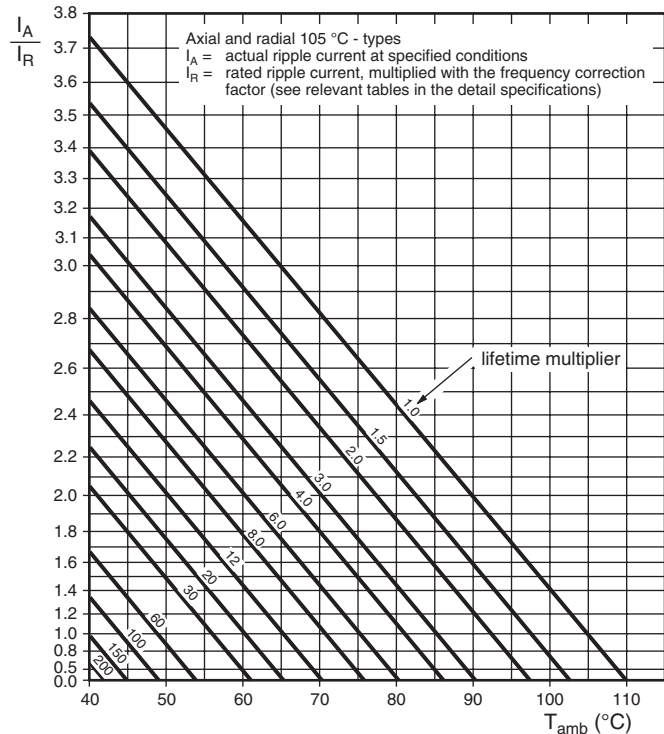
At the intersection of these two operational conditions the appropriate multiplier (correction factor) for useful life can be read. The useful life under certain conditions shall be calculated by multiplying (or dividing respectively) the specified useful life, with the resultant correction factor.

The useful life determined by this procedure is normally valid for applications without forced cooling. Under certain conditions and with additional cooling, the useful life may be considerably extended.



Axial and radial 85 °C types

Fig.15 Typical example of a life-time nomogram: useful life as a function of ambient temperature and ripple current load



Axial and radial 105 °C types

Fig.16 Typical example of a life-time nomogram: useful life as a function of ambient temperature and ripple current

EXAMPLES FOR THE USE OF ‘LIFE-TIME NOMOGRAMS’

Example 1

Temperature in (operating) equipment is 45 °C.

Ripple current load is exactly the rated value (thus: $I_A/I_R = 1$).

Which useful life can be expected (without pause and storage times):

1. for a capacitor with a specified useful life of 2000 hours at 85 °C
2. for a capacitor with a specified useful life of 2000 hours at 105 °C

Solution:

The corresponding life-time multiplier may be found at the intersection between the vertical ‘45 °C-line and the horizontal ‘1’-line. For the 85 °C type this is ‘30’ (see Fig.15) and for the 105 °C type it is ‘90’ (see Fig.16).

Resulting useful life is thus:

1. for 85 °C type: 30 x 2000 hours = 60 000 hours or about 7 years
2. for 105 °C type: 90 x 2000 hours = 180 000 hours or about 20 years.

Example 2

Which life time requirement has to be fulfilled by the capacitors, if the equipment life shall be 10 years (approx. 100 000 hours), consisting of 1000 hours at 75 °C + 9000 hours at 65 °C + 90 000 hours at 40 °C
No ripple current applied (thus: $I_A/I_R = 0$).

Solution:

The mentioned life-times shall be converted to specified 85 °C or 105 °C life-times, i.e. they have to be divided through the correction factors found at the intersection of the respective operational conditions (see Table 4).

The required life-time can be fulfilled by types with a specified useful life of:

1. > 2970 hours at 85 °C i.e. a 3000 hours/85 °C type, or
2. > 935 hours at 105 °C i.e. a 1000 hours/105 °C type.

Example 3

Which internal temperature may occur in the equipment, if the actual ripple current at 10 kHz is 3 times higher than specified for a 16 V-type and the load limit may not be exceeded?

Solution:

The ripple current must first be converted from 10 kHz to 100 Hz by using the conversion table (see typical example, Table 3). This shows that the conversion factor for a 16 V-type is 1.2.

$I_A/I_R = 3$ at 10 kHz and must be divided by 1.2, resulting in $I_A/I_R = 2.5$ at 100 Hz.

The load limit is defined by the diagonal line ‘multiplier 1’ in the relevant nomogram.

This means here: the vertical line on the intersection of $I_A/I_R = 2.5$ and the multiplier 1-line shows the maximum permitted internal temperature:

1. for 85 °C types this is max. 59 °C
2. for 105 °C types this is max. 79 °C

The corresponding life-time in this case is equal to the specified useful life.

Table 3

TYPICAL EXAMPLE OF A FREQUENCY CONVERSION TABLE ⁽¹⁾			
FREQUENCY (Hz)	I _R MULTIPLIER		
	U _R = 6.3 to 25 V	U _R = 35 and 40 V	U _R = 50 and 63 V
50	0.95	0.85	0.80
100	1.00	1.00	1.00
300	1.07	1.20	1.25
1000	1.12	1.30	1.40
3000	1.15	1.35	1.50
≥ 10 000	1.20	1.40	1.60

Note

⁽¹⁾ (I_R / I_R) as a function of frequency; I_R = rated ripple current at 100 Hz

Table 4

LIFE-TIME CALCULATION in "example 2"		
LIFE CONDITIONS	85 °C TYPES (see Fig.15)	105 °C TYPES (see Fig.16)
1000 h at 75 °C	1000/2.9 = 345 h	1000/8 = 125 h
9000 h at 65 °C	9000/6 = 1500 h	9000/20 = 450 h
90 000 h at 40 °C	90 000/80 = 1125 h	90 000/250 = 360 h
	sum for 85 °C = 2970 h	sum for 105 °C = 935 h

FAILURE RATE (λ) TOTAL FAILURE PERCENTAGE

Aluminum capacitors, like many other electronic components and devices, exhibit a failure rate which varies with time as depicted in the familiar 'bathtub' curve (see Fig.17). Three distinct regions can be discerned:

- (a) Burn-in period, showing a rapidly decreasing failure rate. During production of Vishay BCcomponents' aluminum capacitors all capacitors undergo a re-forming process which is a short burn-in. All capacitors shipped have passed burn-in.
- (b) Constant failure period, showing a low failure rate for a long period. This is the 'useful life' period of the aluminum capacitor. The detail specifications of the relevant series specify the upper limit for the total failure percentage (TFP) during this period. For non-solid aluminum capacitors this limit is usually not reached before the wear-out period begins.
- (c) Wear-out period, showing an increasing failure rate due to gradual deterioration. For aluminum capacitors with non-solid electrolyte, the onset of this period can be calculated with the nomogram (see Fig.18).

The failure rate is the number of components failing within a unit of time. For region (b), where the failure rate has a constant value λ, the total failure percentage as a function of time, TFP(t), can be expressed as:

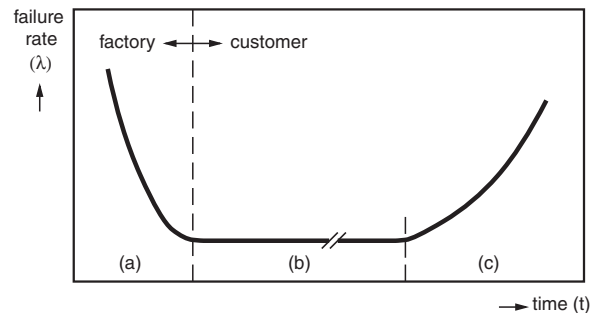
$$TFP(t) = \left\{ 1 - \frac{N(t)}{N(0)} \right\} \times 100 \% = (1 - e^{-\lambda \times t}) \times 100 \%$$

with

$$\lambda = (\lambda_{40\text{ °C}, 0.5 U_R} \times \text{mult})(T, U/U_R)$$

N(t) is the number of components that have not failed after time t. As λ mainly depends on two stress factors, temperature and the ratio of applied voltage to rated voltage, it is common to normalise it to reference conditions, T_{amb} = 40 °C and U = 0.5 x U_R. The value for λ_{40 °C, 0.5 U_R} is calculated from results of periodical tests in the quality laboratories or derived from field observations.

In order to calculate λ for other operating conditions, the value for the failure rate multiplying factor, mult (T, U/U_R) in the formula above, must be taken from Fig.18 (non-solid aluminum capacitors) or Fig.19 (solid aluminum capacitors).



- a) Initial failure period ('infant mortality')
- b) Random failure period (= useful life period)
- c) Wear-out failure period

Fig.17 Failure rate (λ) as a function of time ('bathtub' curve)

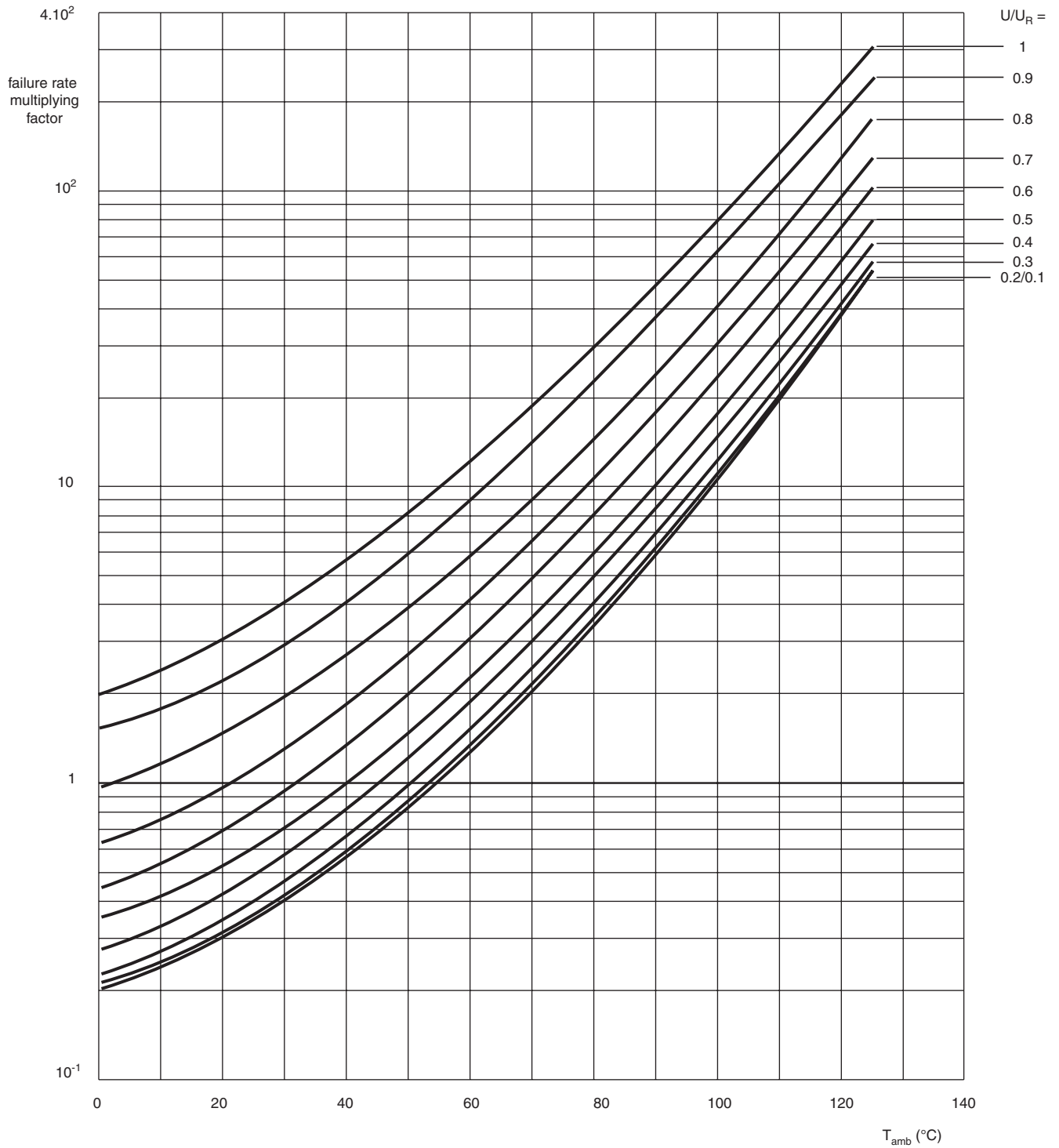


Fig.18 Conversion factors for failure rate (λ) as a function of ambient temperature (T_{amb}) and voltage ratio (U/U_R) for non-solid aluminum capacitors

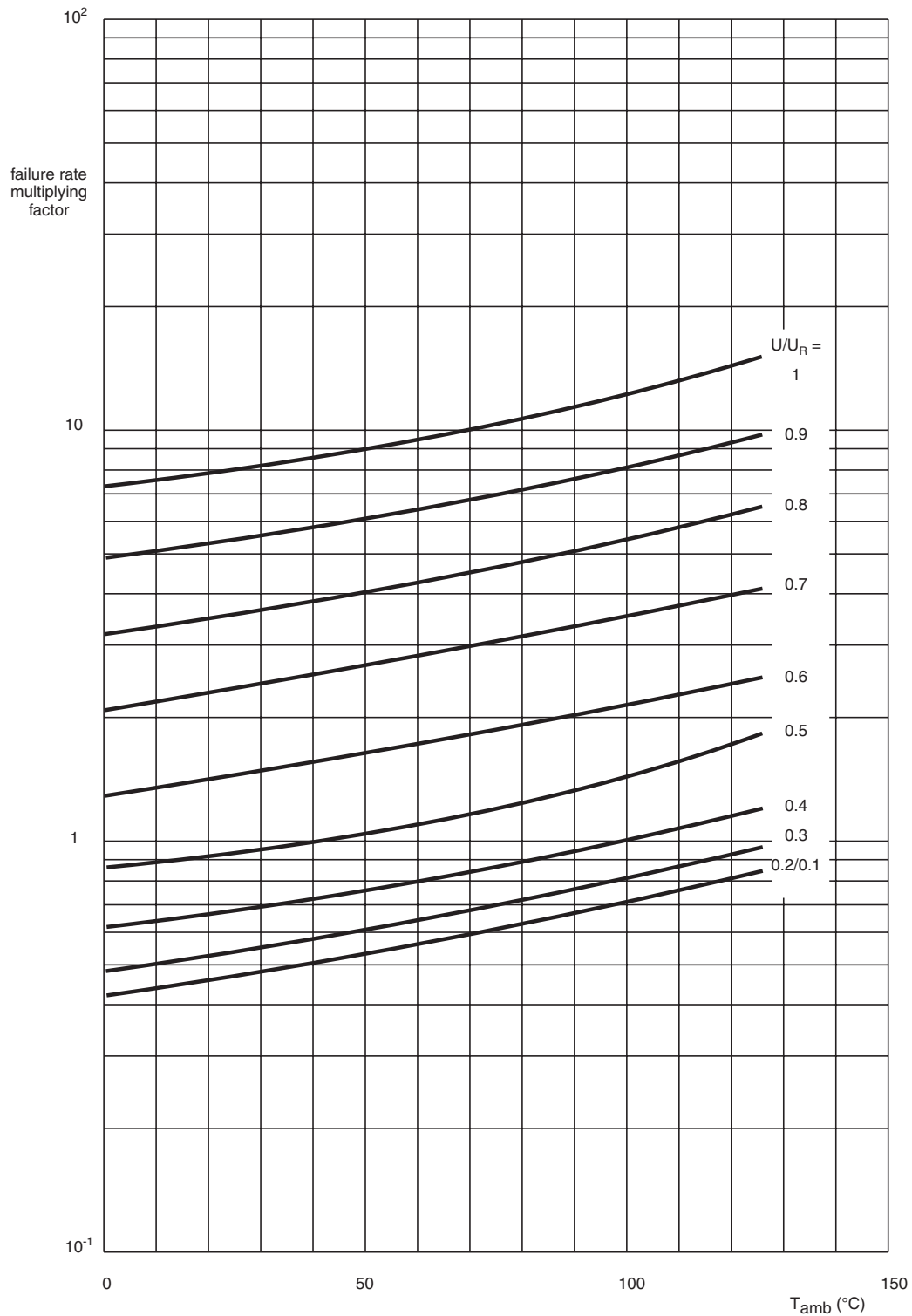


Fig.19 Conversion factors for failure rate (λ) as a function of ambient temperature (T_{amb}) and voltage ratio (U/U_R) for solid aluminum capacitors

**CLIMATIC CATEGORY**

For each capacitor range the climatic category in accordance with “IEC 60068-1” is stated in the relevant detail specification. The climatic category consists of three digit groups; example given in Table 5.

Table 5

EXAMPLE OF CLIMATIC CATEGORIES				
Example:	40	085	56	
	40			lower category temperature (here: - 40 °C)
		085		upper category temperature (here: + 85 °C)
			56	duration of test 'damp heat, steady state' (here: 56 days)

Table 6

MAXIMUM HUMIDITY CONDITION INDICATION FOR THE APPLICATION CLASS				
CODE LETTER	RELATIVE AIR HUMIDITY			
	YEARLY AVERAGE	30 DAYS PER YEAR	OCCASIONALLY	DEWING
C	≤ 95 %	100 %	100 %	permitted
D	≤ 80 %	100 %	90 %	permitted
E	≤ 75 %	95 %	85 %	slightly/rarely
F	≤ 75 %	95 %	85 %	not permitted

APPLICATION CLASS

Although the German standard “DIN 40040” has been withdrawn, it is still widely used in industrial specifications for the definition of climatic working conditions. The application class consists of 3 code letters which have the following meanings.

CODE LETTER MEANINGS

1 st letter:	lower category temperature F: - 55 °C; G: - 40 °C; H: - 25 °C
2 nd letter:	upper category temperature P: + 85 °C; M: + 100 (+ 105) °C; K: + 125 °C
3 rd letter:	maximum humidity conditions (see Table 6)

MOUNTING**MOUNTING POSITION OF NON-SOLID ALUMINUM CAPACITORS**

Snap-in and printed wiring (PW) as well as solder lug (SL) aluminum capacitors, in addition to the larger case sizes of axial and radial types, are normally equipped with pressure relief in the aluminum case. These and all smaller case size types, may be mounted in any position.

Screw-terminal aluminum capacitors have a pressure relief in the sealing disc. These types shall be mounted so that no emissions of electrolyte or vapour may reach either the conductors under voltage, or other parts of the printed circuit board. Vertical (pressure relief up) or horizontal (pressure relief on the upper side) mounting position is recommended.

DESIGN RULES FOR ‘CAPACITOR BATTERIES’**MECHANICAL**

Vishay BCcomponents large aluminum capacitors are mainly used in power supply applications under high ripple current load. In these circumstances, the capacitors must be mounted with a distance of ≥ 15 mm from each other, in order to allow sufficient air circulation and to prevent mutual radiation.

Likewise, if axial or radial types are subject to high ripple load, they shall be mounted with sufficient distance (e.g. ≥ 10 mm) from each other for good convection.

ELECTRICAL*Parallel connection*

Aluminum capacitors may be connected in parallel, but for safety reasons, large sizes should be individually guarded against sudden energy discharge of the whole battery due to a defective specimen.

Series connection

If two aluminum capacitors are connected in series, balancing resistors are required; see Fig. 20. Without these resistors, leakage current through both capacitors is the same. Because the leakage current for two capacitors can be quite different when the same voltage is applied, forcing the same current through both capacitors will mean that the voltage will not divide evenly. One capacitor might be subjected to a voltage exceeding its rated voltage. Parallel balancing resistors limit the difference in voltage across the capacitors under DC conditions.

For practical purposes the following equation can be used to calculate the maximum possible resistor

$$\text{values in ohms: } R = \frac{2 \times U_m - U_{\text{total}}}{I_{L5}}$$

Here, U_m is the maximum (rated) voltage that may be present on one of the capacitors and I_{L5} is the specified leakage current in amperes after 5 minutes (used as an approximation of the difference in leakage current between C1 and C2).

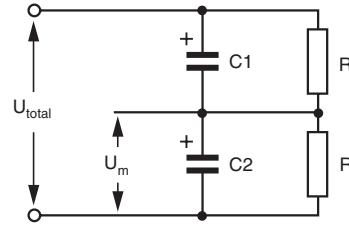


Fig.20 Balancing resistors for two aluminum capacitors in series

Combined series/parallel connection

The above mentioned rules for both series and parallel connection are accordingly valid for any combination of these two cases.



MARKING

Vishay BCcomponents aluminum capacitors are identified in accordance with "IEC" rules. When sufficient space is available, capacitors are marked with the following details:

Rated capacitance	in μ F (the 'μ' sign represents the position of the decimal point)	
Rated voltage	in V	
Tolerance on rated capacitance	if necessary, as a letter code in accordance with "IEC 60062", e.g. T for - 10/+ 50 % M for \pm 20 % K for \pm 10 % Q for - 10/+ 30 % A for tolerance according to detail specification	
Group number	3-digit part of the catalog number, e.g. 036 for RSP series	
Catalog number	or last 8-digits of the catalog number	
Name of manufacturer	BCcomponents or BCC or BC	
Date code	abbreviation in 2 digits ("IEC 60062"), e.g. 1 st digit R = 2003 S = 2004 T = 2005 U = 2006 V = 2007 W = 2008 X = 2009 A = 2010 B = 2011 2 nd digit 1 = January 2 = February ... 9 = September O = October N = November D = December	

example:

WO = produced in 2008, October

production date may also be stated as year/week code

Date code may also be stamped in the case.

Factory code indicating the factory of origin

Polarity identification strip, band or negative symbol ('-' sign) to indicate the negative terminal and/or a '+' sign to identify the positive terminal.



Aluminum Capacitors

WARNING

Correct application and strict adherence to the important information listed below will ensure optimum performance of the capacitors over their entire specified useful life.

Please note that ignoring these rules may reduce the equipment lifetime or even destroy the capacitor, together with parts of the equipment or property involved. The consequences may be a short or open circuit of the component, leakage of electrolyte or heat generation. Opening of the case or vent (danger of injury) may be regarded as hazardous and cause liquids, vapors or dust to be released. Similar precautions should be taken when testing aluminum capacitors.

Please consult your local Vishay sales organization, if one or more of these limits cannot be adhered to.

GUIDELINES		
PARAMETER	IMPORTANT INFORMATION - PRODUCT SAFETY	MORE DETAILS
DESIGN		
VOLTAGE	<p>Do not apply a voltage exceeding the capacitor's voltage rating.</p> <p>Check the maximum voltage across the capacitor that may occur over the whole equipment life. In normal operation the rated voltage of the capacitor shall not be exceeded; if so, early failures may occur. However, for short periods the voltage may be raised up to surge voltage value (see Detail Specification); for conditions and maximum parameter changes, see section "Tests and Requirements".</p>	<p>Detail Specification</p> <p>TESTS AND REQUIREMENTS</p>
RIPPLE LOAD	<p>Do not allow excessive ripple current to pass.</p> <p>The rated ripple current as calculated for the application conditions (see section "Introduction"), shall not be exceeded. If so, early failure may result.</p> <p>Keep ripple voltage within ratings.</p> <p>The sum of DC-bias and maximum amplitude of ripple voltage shall be within rated voltage and 0 V. Aluminum capacitors are not normally designed for AC application.</p>	<p>Detail Specification</p> <p>INTRODUCTION</p>
TEMPERATURE CHANGE	<p>Use capacitors within specified temperature range.</p> <p>Applicable temperature range is given in the relevant detail specification.</p> <p>A general principle is that lower ambient temperature means longer life; therefore, wherever possible, aluminum capacitors should be placed at the coolest positions on the board (please ensure that aluminum capacitors are placed away from 'heating' components such as power resistors, switching diodes/transistors or transformers). Exceeding the permitted temperature range may cause early failures.</p>	<p>Detail Specification</p>
CHARGE-DISCHARGE	<p>Observe charge-discharge limitations.</p> <p>Frequent charge-discharge load via low resistance may cause capacitance drop or destroy the capacitor. Under well defined conditions (see section "Tests and Requirements") frequent charge-discharge operation is allowed. The resulting current through the capacitor must not exceed the ripple current limit. Standard aluminum capacitors are not suitable for flash applications.</p>	<p>TESTS AND REQUIREMENTS</p>
SERIES/PARALLEL CONNECTIONS	<p>When connecting in series/parallel, apply corresponding design rules.</p> <p>Connecting aluminum capacitors in series/parallel is possible, provided that balancing resistors are applied to each capacitor, in order to stabilize the voltage over each individual capacitor. Rules for correct design are given in section "Introduction".</p>	<p>INTRODUCTION</p>
PC BOARD DESIGN	<p>Conducting tracks or lands should not be located under upright mounted aluminum capacitors; short circuits under the capacitor with danger of fire could be the result.</p>	
INSULATION	<p>The capacitor case is not insulated from the cathode terminal.</p> <p>Axial capacitors have a direct contact between case and cathode terminal; radial and power capacitors exhibit an indeterminate resistance between the cathode terminal and the metal case. Metal parts other than terminals should never make contact with conducting tracks or metal parts of other components. Dummy pins should be connected to the cathode.</p>	
MOUNTING		
POLARITY, REVERSE VOLTAGE	<p>Aluminum capacitors for DC applications require polarization.</p> <p>Check the polarity of each capacitor: both in circuit design and in mounting (polarity is clearly indicated on the capacitor). For short periods a limited reverse voltage is allowed (see Detail Specification); for conditions and maximum parameter changes, see section "Tests and Requirements". Exceeding reverse voltage may result in early failures.</p>	<p>Detail Specification</p> <p>TESTS AND REQUIREMENTS</p>



GUIDELINES		
PARAMETER	IMPORTANT INFORMATION - PRODUCT SAFETY	MORE DETAILS
PLACEMENT	<p>Avoid excessive stress to the lead wires or terminals.</p> <p>Excessive stress can be caused by component processing machines if lead wires are not sufficiently fixed during bending, cutting, cropping or inserting operations. Other possible reasons are incorrect hole distance on the printed circuit or bending of the component after soldering. Care should be taken when the manual bending of terminals or mounted capacitors is required. For maximum allowed mechanical load and time of application, see section <i>"Tests and Requirements"</i>.</p> <p>Mechanically damaged capacitors may not be used.</p> <p>Pressure relief should have enough space to function correctly.</p>	TESTS AND REQUIREMENTS
SOLDERING	<p>Keep soldering temperature and time under control.</p> <p>For maximum soldering conditions, see section <i>"Tests and Requirements"</i>. Additional temperature load e.g. for curing the glue of Surface Mount Devices (SMDs) are allowed to a certain limit, which depends on series and exact details. Please apply to your sales engineer for your specific conditions. Molten solder or the soldering iron should not make contact with the capacitor's insulation. Reflow soldering is only suitable for SMD components.</p>	TESTS AND REQUIREMENTS
BOARD CLEANING	<p>No guarantees can be given with regard to solvents based on halogenated hydrocarbons or ozone depleting chemicals (ODCs).</p> <p>Warning: such solvents are hazardous to the environment.</p> <p>Component cleaning using solvents such as demineralized or distilled water, isopropanol, methanol, ethanol and propanol would not normally have any detrimental effects and therefore do not require any special precautions. Aqueous cleaning methods may be used in conjunction with saponification using a neutral detergent like calgonite at 20 g/l. It is recommended that immediate drying of the component in hot air is carried out at approximately 85 °C (or 70 °C for products with an upper category temperature of 70 °C) for at least 5 minutes. For further information regarding the application of solvent temperatures exceeding the temperature mentioned in <i>"IEC 60068-2-45"</i>, consult your local Vishay sales organization.</p>	
ADHESIVES, COATING MATERIALS	<p>Some adhesives and coating materials affect capacitors adversely.</p> <p>For varnishing, coating, lacquering, embedding or gluing at the capacitor's sealing, ensure that the materials used are halogene-free in all their constituent parts (base material, thinners, binders, reacting agents, propellants, additives). For reasons see 'BOARD CLEANING' above.</p> <p>When applying such materials, ensure that the rubber area is not completely sealed off.</p>	
STORAGE AND TRANSPORT		
STORAGE CONDITIONS, HANDLING	<p>Excessive storage time or conditions may have adverse effects on capacitors.</p> <p>Capacitors should be stored at room temperature, low humidity and out of direct sunlight. Storage at elevated temperature and/or high relative humidity may have a negative influence on taping accuracy, solderability, leakage current and life expectancy.</p> <p>Packages with aluminum capacitors should be handled with care, otherwise bent leads and/or incorrect taping dimensions could be the result.</p>	INTRODUCTION TESTS AND REQUIREMENTS
HIGH AIR PRESSURE	<p>Do not expose capacitors to overpressure.</p> <p>Maximum operating pressure is 150 kPa. Higher pressure may cause a short circuit.</p>	
LOW AIR PRESSURE	<p>The capacitors may be used up to an altitude of $\leq 12\ 000$ m.</p> <p>Minimum air pressure: 8.5 kPa for short periods (in accordance with <i>"IEC 60384-4, sub clause 4.11.4"</i>).</p>	TESTS AND REQUIREMENTS
DISINFECTING E.G. FOR SARS	<p>No guarantees can be given when disinfectants are/have been used.</p> <p>Disinfectants may contain halogens like chlorine, fluorine, bromine etc. and alkaline solutions. Disinfectants should not be used near or on the capacitor. Over time they can cause corrosive reactions to capacitors resulting in reduced capacitance, open circuits etc.</p> <p>For further information please consult your local Vishay sales organization</p>	
EMERGENCY		
PERSONNEL SAFETY	<p>WARNING NOTE.</p> <p>Non-solid aluminum capacitors may contain chemicals which can be regarded as hazardous if handled incorrectly. Caution is necessary if the outer case is fractured; vapors or dust particles should not be inhaled (good ventilation is essential); skin, eye or clothing contact with liquids should be avoided. In case of such contact, flush thoroughly with running water as soon as possible, then wash skin or clothing with soap and water or a mild detergent. Any possible discoloration of the wetted skin will disappear after a few days.</p> <p>In the event of fire, the organic parts of aluminum capacitors may release such constituents as carbon monoxide, nitric oxides or dust particles; take caution when breathing-in.</p>	
END OF LIFE		
DISPOSAL	<p>Aluminum capacitors are subject to special waste regulations.</p> <p>Aluminum capacitors are free from PCB- or PBDE-containing substances. Dioxines or furanes are not constituent parts of aluminum capacitors. However, because of other polluting ingredients, larger quantities (in weight) of aluminum capacitors are subject to special waste regulations in accordance with the relevant national laws; please consult your local Vishay sales organization.</p> <p>In general, disposal of aluminum capacitors must take place under controlled circumstances in a high temperature incinerator at minimum 900 °C.</p>	

Aluminum Capacitors

TESTS AND REQUIREMENTS

This datasheet contains an abridged version of tests and requirements given in "IEC 60384-4" or "EN130300" respectively. Correct sequence of measurement for electrical parameters in accordance with "IEC 60384-4":

1. Leakage current
2. Capacitance
3. $\tan \delta$ or ESR
4. Impedance

Table 1

NON-SOLID ALUMINUM TYPES				
NAME OF TEST	IEC 60384-4/ EN130300 SUBCLAUSE	IEC 60068-2 TEST METHOD	PROCEDURE (quick reference)	REQUIREMENTS
Robustness of terminations: Tensile strength	4.4	Ua	leaded types: loading force 10 N for 10 s power types: loading force 20 N for 10 s	no visible damage
Bending		Ub	leaded types: loading force 5 N two consecutive bends	no visible damage
Torsion		Uc	leaded types, axial: two successive rotations of 180° in opposite direction; 5 s per rotation	no visible damage
Torque on nut (stud)		Ud	power types/screw terminal: torque of 176 Nm gradually applied	no visible damage
Resistance to soldering heat	4.5	Tb (method 1A)	solder bath: 260 °C; 10 s	no visible damage; marking legible $\Delta C/C: \pm 5 \%$
Solderability	4.6	Ta	solder bath: 235 °C; 2 s; immersed up to 2 mm from the body; non activated flux	no visible damage; marking legible $\geq 95 \%$ tinning
Rapid change of temperature	4.7	Na	for Snap-In, DIN-PW and Screw Terminal capacitors: 5 cycles of 3 h at lower and upper category temperature for axial, radial and SMD capacitors: 5 cycles of 30 min at lower and upper category temperature	no visible damage; no leakage of electrolyte
Vibration ⁽¹⁾	4.8	Fc	10 Hz to 500 Hz; 0.75 mm or 10 g (whichever is less); 3 directions; 2 h per direction form MR or ST types: 10 Hz to 55 Hz; 0.75 mm or 10 g (whichever is less); 3 directions; 2 h per direction	no visible damage; no leakage of electrolyte; marking legible $\Delta C/C: \pm 5 \%$ with respect to initial measurements
Bump ⁽¹⁾	4.9	Eb	40 g; 2 directions; 4000 bumps total form MR: 40 g; 2 directions; 1000 bumps total	no visible damage; no leakage of electrolyte $\Delta C/C: \pm 5 \%$ with respect to initial measurement
Climatic sequence: Dry heat	4.11 4.11.1	Ba	16 h at upper category temperature; no voltage applied	no visible damage; no leakage of electrolyte
Damp heat, cyclic	4.11.2	Db	1 cycle (55 °C → 25 °C) of 24 h; RH 95 % to 100 %; no voltage applied	
Cold	4.11.3	Aa	2 h at lower category temperature; no voltage applied	



NON-SOLID ALUMINUM TYPES				
NAME OF TEST	IEC 60384-4/ EN130300 SUBCLAUSE	IEC 60068-2 TEST METHOD	PROCEDURE (quick reference)	REQUIREMENTS
Low air pressure	4.11.4	M	5 min at 25 °C ± 10 °C; at atmospheric pressure of 8.5 kPa; U _R applied during last min	no visible damage; no evidence of breakdown or flashover
Damp heat, cyclic	4.11.5	Db	5 cycles (55 °C → 25 °C) of 24 h each; RH 95 % to 100 %; no voltage applied	
Sealing	4.11.6	Qc	1 min in water at 90 °C	no continuous chain of bubbles
	4.11.7		final measurement after climatic sequence	no visible damage; no leakage of electrolyte; marking legible leakage current ≤ stated limit tan δ ≤ 1.2 x stated limit ΔC/C: ± 10 %
Insulation resistance	4.3.5		insulation sleeve: foil method	insulation resistance ≥ 100 MΩ
Voltage proof	4.3.6		insulation sleeve: foil method; 1000 V for 1 min	no breakdown or flashover
Damp heat, steady state	4.12	Ca	56 d at 40 °C; RH 90 % to 95 %; no voltage applied	no visible damage; no leakage of electrolyte; marking legible leakage current ≤ stated limit tan δ ≤ 1.2 x stated limit insulation resistance > 100 MΩ; no breakdown or flashover below 1000 V ΔC/C: ± 10 %
Endurance	4.13		for test duration, refer to the relevant datasheet in this data book; at upper category temperature; U _R applied	no visible damage; no leakage of electrolyte; marking legible leakage current ≤ stated limit insulation resistance > 100 MΩ; no breakdown or flashover below 1000 V U _R ≤ 6.3 V; ΔC/C: + 15 %/- 30 %; 6.3 V < U _R < 200 V; ΔC/C: ± 15 %; U _R ≥ 200 V; ΔC/C: ± 10 % tan δ ≤ 1.3 x stated limit impedance ≤ 2 x stated limit
Surge	4.14		from source of 1.15 x U _R for U _R ≤ 315 V or 1.1 x U _R for U _R > 315 V RC = 0.1 s ± 0.05 s 1000 cycles of 30 s on, 330 s off, at upper category temperature	no visible damage; no leakage of electrolyte leakage current ≤ stated limit tan δ ≤ stated limit ΔC/C: ± 15 %



NON-SOLID ALUMINUM TYPES				
NAME OF TEST	IEC 60384-4/ EN130300 SUBCLAUSE	IEC 60068-2 TEST METHOD	PROCEDURE (quick reference)	REQUIREMENTS
Reverse voltage	4.15		1 V in reverse polarity followed by U_R in forward polarity, both for 125 h at upper category temperature	leakage current \leq stated limit $\tan \delta \leq$ stated limit $\Delta C/C: \pm 10 \%$
Pressure relief (only for types with vent)	4.16		DC voltage applied in reverse direction producing a current of 1 A to 10 A	pressure relief opens prior to danger of explosion or fire
Storage at upper category temperature	4.17	Ba	test duration 500 h at upper category temperature; for longer test duration (shelf life), refer to the relevant datasheet in this data book	no visible damage; no leakage of electrolyte leakage current $\leq 2 \times$ stated limit $\tan \delta \leq 1.2 \times$ stated limit $\Delta C/C: \pm 10 \%$
Storage at low temperature	4.18	Ab	72 h at the lower category temperature	no visible damage; no leakage of electrolyte leakage current \leq stated limit $\tan \delta \leq$ stated limit $\Delta C/C: \pm 10 \%$
Characteristics at high and low temperatures	4.19		step 1: reference measurement of impedance at 20 °C and 100 Hz	
		Aa	step 2: measurement at lower category temperature	impedance at 100 Hz: $\leq 7 \times$ value of step 1 for $U_R \leq 6.3 \text{ V}$ or $U_R > 160 \text{ V}$; $\leq 5 \times$ value of step 1 for $6.3 \text{ V} < U_R \leq 16 \text{ V}$; $\leq 4 \times$ value of step 1 for $16 \text{ V} < U_R < 160 \text{ V}$
		Ba	step 3: measurement at upper category temperature	leakage current: $\leq 10 \times$ stated limit at 125 °C; $\leq 8 \times$ stated limit at 105 °C; $\leq 5 \times$ stated limit at 85 °C; $\leq 3 \times$ stated limit at 70 °C
Charge and discharge	4.20		for $U_R \leq 160 \text{ V}$: 10^6 cycles of 0.5 s charge to U_R (RC = 0.1 s) and 0.5 s discharge (RC = 0.1 s); for $U_R > 160 \text{ V}$: under consideration	no visible damage; no leakage of electrolyte $\Delta C/C: \pm 10 \%$
Additional tests in accordance with IEC 60384-1 and EN 130000				
Solvent resistance	4.31	Xa	immersion: 5 min \pm 0.5 min with or without ultrasonic at 55 °C \pm 0.5 °C solvents: demineralized water and/or calgonite solution (20 g/l)	visual appearance not affected
Passive flammability	4.38	IEC 60695-2-2	needle flame test	category of flammability: B

Notes

For vibration and bump testing, the components shall be mounted by their terminations (with mounting accessories where applicable). The following capacitors shall also be clamped by their body:

- a) Radial types: $\varnothing D_{nom} \geq 12.5 \text{ mm}$; $L_{nom} \geq 15 \text{ mm}$
- b) Axial types: $\varnothing D_{nom} \geq 12.5 \text{ mm}$; $L_{nom} \geq 30 \text{ mm}$



Table 2

SOLID ALUMINUM TYPES, SAL				
NAME OF TEST	IEC 60384-4/ EN130300 SUBCLAUSE	IEC 60068-2 TEST METHOD	PROCEDURE (quick reference)	REQUIREMENTS
Robustness of terminations: Tensile strength ⁽¹⁾ Bending ⁽¹⁾ Torsion (axial types)	4.4	Ua Ub Uc	loading force; 10 N for 10 s loading force; 5 N; two consecutive bends two successive rotations of 180° in opposite direction; 5 s duration per rotation	no visible damage no visible damage no visible damage
Resistance to soldering heat	4.5	Tb (method 1A)	radial types: solder bath: 260 °C; 10 s	no visible damage; markings legible
		Tb (method 1B)	axial types: solder bath 350 °C for 3.5 s	$\Delta C/C: \pm 5\%$ with respect to initial measurement
Solderability	4.6	Ta (method 1)	solder bath: 235 °C; 2 s immersed up to 2 mm from the body; non activated flux	no visible damage; marking legible $\geq 95\%$ tinning
Rapid change of temperature	4.7	Na	5 cycles of 30 min at lower and upper category temperature	no visible damage leakage current $\tan \delta$ and $Z \leq$ stated limit
Vibration ⁽²⁾	4.8	Fc	10 Hz to 500 Hz; 0.75 mm or 10 g (whichever is less severe); in 3 directions; 2 h per direction	no visible damage; markings legible $\Delta C/C: \pm 5\%$ with respect to initial measurement
			128 SAL-RPM: 10 Hz to 2000 Hz; 1.5 mm or 20 g (whichever is less severe); in 3 directions; 2 h per direction	no visible damage; markings legible $\Delta C/C: \pm 5\%$ with respect to initial measurement
Bump ⁽²⁾	4.9	Eb	40 g; 2 directions; 4000 bumps total	no visible damage $\Delta C/C: \pm 5\%$ with respect to initial measurement
Shock ⁽²⁾	4.10	Ea	123 SAL-AG: acceleration: 29 400 m/s ² or 3000 g; duration of pulse: 0.2 ms; total number of shocks: 18	no visible damage $\Delta C/C: \pm 5\%$ with respect to initial measurement



SOLID ALUMINUM TYPES, SAL				
NAME OF TEST	IEC 60384-4/ EN130300 SUBCLAUSE	IEC 60068-2 TEST METHOD	PROCEDURE (quick reference)	REQUIREMENTS
Climatic sequence: Dry heat	4.11			
	4.11.1	Ba	16 h at upper category temperature; no voltage applied	no breakdown, flashover, or harmful deformation of case
Damp heat, cyclic	4.11.2	Db	1 cycle (55 °C → 25 °C) of 24 h; RH 95 % to 100 %; no voltage applied	
Cold	4.11.3	Aa	2 h at lower category temperature; no voltage applied	
Low air pressure	4.11.4	M	5 min at 25 °C ± 10 °C; atmospheric pressure: 8.5 kPa; U _R applied during last min of test	
Damp heat, cyclic	4.11.5	Db	5 cycles (55 °C → 25 °C) of 24 h each; 25 °C; RH 95 % to 100 %; no voltage applied	
	4.11.7		final measurements after climatic sequence	no visible damage; markings legible leakage current ≤ stated limit tan δ and Z ≤ 1.2 x stated limit
Damp heat, steady state	4.12	Ca	56 d at 40 °C; RH 90 % to 95 %; no voltage applied	no visible damage; markings legible leakage current ≤ stated limit tan δ and Z ≤ 1.2 x stated limit ΔC/C: ± 10 % of initial measurement
Insulation resistance	4.3.5		insulation sleeve: foil method	insulation resistance ≥ 100 MΩ
Voltage proof	4.3.6		insulation sleeve: foil method; 1000 V for 1 min	no breakdown or flashover
Endurance	4.13		for test duration, refer to the relevant datasheet in this data book; at upper category temperature; U _R applied ⁽³⁾	no visible damage; markings legible leakage current ≤ stated limit ΔC/C: ± 10 % with respect to initial measurement tan δ and Z ≤ 1.2 x stated limit axial types: insulation resistance ≥ 100 MΩ; no breakdown or flashover at 1000 V
Endurance (additional)			2000 h at 175 °C; maximum 0.63 x U _R applied	leakage current ≤ stated limit ΔC/C: ± 20 % with respect to initial measurement tan δ ≤ 1.5 x stated limit Z ≤ 2.5 x stated limit



SOLID ALUMINUM TYPES, SAL					
NAME OF TEST	IEC 60384-4/ EN130300 SUBCLAUSE	IEC 60068-2 TEST METHOD	PROCEDURE (quick reference)	REQUIREMENTS	
Surge	4.14		applied voltage source of 1.15 x U _R ⁽³⁾ at 125 °C; 1000 cycles; 30 s on, 330 s off	no visible damage leakage current ≤ stated limit tan δ ≤ stated limit	
				axial types: ΔC/C: ± 5 % with respect to initial measurement	
				radial types: ΔC/C: ± 10 % with respect to initial measurement	
Reverse voltage	4.15		0.15 x U _R ⁽³⁾ in reverse polarity at 125 °C for 125 h, followed by U _R ⁽³⁾ in forward polarity at 125 °C for 125 h	leakage current ≤ stated limit ΔC/C: ± 10 % with respect to initial measurement tan δ and Z ≤ stated limit	
Reverse voltage (additional): Radial types				0.30 x U _R ⁽³⁾ in reverse polarity at 125 °C for 125 h, followed by U _R ⁽³⁾ in forward polarity at 125 °C for 125 h	leakage current ≤ stated limit ΔC/C: ± 10 % with respect to initial measurement tan δ and Z ≤ stated limit
Reverse voltage (additional): Axial types				0.30 x U _R in reverse polarity at 125 °C for 2000 h	leakage current ≤ stated limit ΔC/C: ± 10 % with respect to initial measurement tan δ and Z ≤ stated limit
Storage at upper category temperature	4.17	Ba	500 h at upper category temperature	no visible damage leakage current ≤ stated limit ΔC/C: ± 10 % with respect to initial measurement	
Long storage ≥ 1 year (additional)			at ambient temperature	leakage current ≤ stated limit	
Characteristics at high and low temperature	4.19		step 1: reference measurement at 20 °C of capacitance, tan δ and impedance at 100 Hz		
			step 2: measurement at - 55 °C; tan δ and impedance at 100 Hz	ΔC/C: ± 20 % with respect to value in step 1 impedance ratio (100 Hz) ≤ 2 x the value of step 1 tan δ ≤ 2 x the stated limit	
			step 3: measurement at 125 °C capacitance, leakage current and tan δ	leakage current ≤ 15 x the stated limit; ⁽⁴⁾ ⁽⁵⁾ ΔC/C: ± 20 % of the value measured in step 1 tan δ ≤ stated limit	
Charge and discharge	4.20		10 ⁶ cycles charging to U _R for 0.5 s, and then discharging for 0.5 s	no visible damage ΔC/C: ± 5 % with respect to initial measurement	



SOLID ALUMINUM TYPES, SAL				
NAME OF TEST	IEC 60384-4/ EN130300 SUBCLAUSE	IEC 60068-2 TEST METHOD	PROCEDURE (quick reference)	REQUIREMENTS
Additional tests in accordance with IEC 60384-1 and EN130000				
Solvent resistance	4.31	Xa	immersion: 5 min ± 0.5 min with or without ultrasonic at 55 °C ± 0.5 °C solvents: demineralized water and/or calgonite solution (20 g/l)	visual appearance not affected
Passive flammability	4.38	IEC 60695-2-2	needle flame test	category of flammability: B

Notes

- (1) SPECIAL PLIERS MUST BE USED TO PROTECT THE CELL BODY AND CONSEQUENTLY KEEP THE BENDING LOCATION UNDER CONTROL.
- (2) Axial capacitors shall be mounted by clamping both the body and the leads.
- (3) U_R at 125 °C is 25 V for 35 V and 40 V versions.
- (4) For radial types, 40 V version: < 8 x the stated limit.
- (5) Leakage current for axial types: $\leq 1.5 \times U_R \times C_R$.



Aluminum Capacitors

INTRODUCTION

For unambiguous processing of customer orders, a component supplier defines a system of product codes to uniquely identify a component, including its packaging. Two systems can be used:

1. Cleartext type
2. Index type

Cleartext Type

In this system the letters/digits in the product code are grouped. Each group has a predefined interpretation. This could be something like “positions number 6 and 7 describe product dimensions”. The accompanying table provides the reserved codes, e.g. “CF” for a radial product corresponds to dimensions 8.5 x 22 mm. The predefined interpretations give a direct link between the product code and the component’s parameters.

Index Type

In this system the product code is the index or sequence number of a record in a database. This record contains all information describing and uniquely identifying the component. Therefore this system does not require a relation between the product code and the component’s parameters.

VISHAY BCCOMPONENTS PRODUCT CODE

The Vishay BCcomponents Product Code, formerly known as 12NC, is an Index type product code. Although this system allows to use random product codes, a systematic approach is used to generate the bulk of the codenumbers. Unfortunately, the number of component variations is larger than the number of variations possible in this system. Therefore the interpretation described below covers about 80 % of the aluminum capacitor product codes found in the datasheets.

GROUP	PRODUCT CODE													
	1				2			3	4	5			6	
DIGIT	1	2	3	4	5	6	7	8	9	10	11	12	13	14
ORDER CODE	M	A	L	2	0	3	8	3	1	4	7	9	E	3
FORMER 12NC	2	2	2	2	0	3	8	3	1	4	7	9		

Note

The order code (MAL....) was introduced in 2007 to accommodate a change in the logistic system. To minimize errors when converting from the former 12NC to the new order code, or vice versa, only six conversion schemes are used:

ORDER CODE	FORMER 12NC	COMMENT
MAL2xxxxyyyyE3	2222 xxx yyyyy	
MAL2xxxxyyyy	2222 xxx yyyyy	For non lead (Pb)-free versions, e.g. 123 SAL-A
MAL2xxxxyyyyE3	2281 xxx yyyyy	See explanation of Group 1
MAL2xxxxyyyyE6	2222 xxx yyyyy	See explanation of Group 6
MAL5xxxxyyyyE3	2215 xxx yyyyy	See explanation of Group 1
MAL8xxxxyyyy	4322 xxx yyyyy	For Accessories

Group 1

This group consists of 4 digits, positions 1 to 4. It can have the following values:

ORDER CODE	FORMER 12NC	COMMENT
MAL2	2222	Most common. No special meaning
MAL2	2281	Lead (Pb)-free, RoHS compliant product. Only used for specific series.
MAL5	2215	Lead (Pb)-free, RoHS compliant product. Only used for specific series.
MAL8	4322	Accessories



Group 2

This group consists of 3 digits, positions 5 to 7. This group identifies the series.

The digits are the same as those in the series name. In some cases a series name contains two groups of three digits. In that case the first group in the series name identifies components with rated voltage ≤ 100 V and the second group the components with rated voltage > 100 V.

Examples

038	Component from 038 RSU series
056	≤ 100 V rated component from 056/057 PSM-SI series
057	> 100 V rated component from 056/057 PSM-SI series

Group 3

This group consists of 1 digit, position 8. This group describes packaging, termination type, case size and tolerance. Due to its many functions, there is no single interpretation.

Example, for radial products

3	Form TFA, taped, wide lead pitch, in ammopack
5	Form CA, bulk packaging, long leads
6	Form CB, bulk packaging, short leads
7	Form TNA, taped, narrow lead pitch, in ammopack

For a non-catalogue component, a.k.a. "special", the digits for Group 3 and Group 4 are "90", as in e.g. MAL203890012E3

Group 4

This group consists of 1 digit, position 9. This group describes the rated voltage. The interpretation of the digit is linked to the coding of Group 2.

≤ 100 V

0	35 V	5	16 V
1	50 V	6	25 V
2	4.0 V/80 V	7	40 V
3	6.3 V	8	63 V
4	10 V	9	100 V

> 100 V

0	Reserved	5	350 V
1	160 V	6	400 V
2	200 V	7	450 V
3	250 V	8	385 V
4	420 V	9	500 V

For a non-catalogue component, a.k.a. "special", the digits for Group 3 and Group 4 are "90", as in e.g. MAL203890012E3

Group 5

This group consists of 3 digits, positions 10 to 12. This group reflects the capacitance value in μF . The first two digits represent the value, the third digit represents the multiplier, e.g. 479 means $47 \times 1 = 47 \mu\text{F}$.

Multiplier (position 12)

0	Not used	5	$\times 100\,000$
1	$\times 10$	6	$\times 1\,000\,000$
2	$\times 100$	7	$\times 0.01$
3	$\times 1000$	8	$\times 0.1$
4	$\times 10\,000$	9	$\times 1$

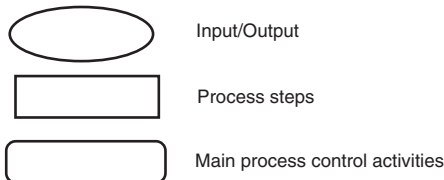
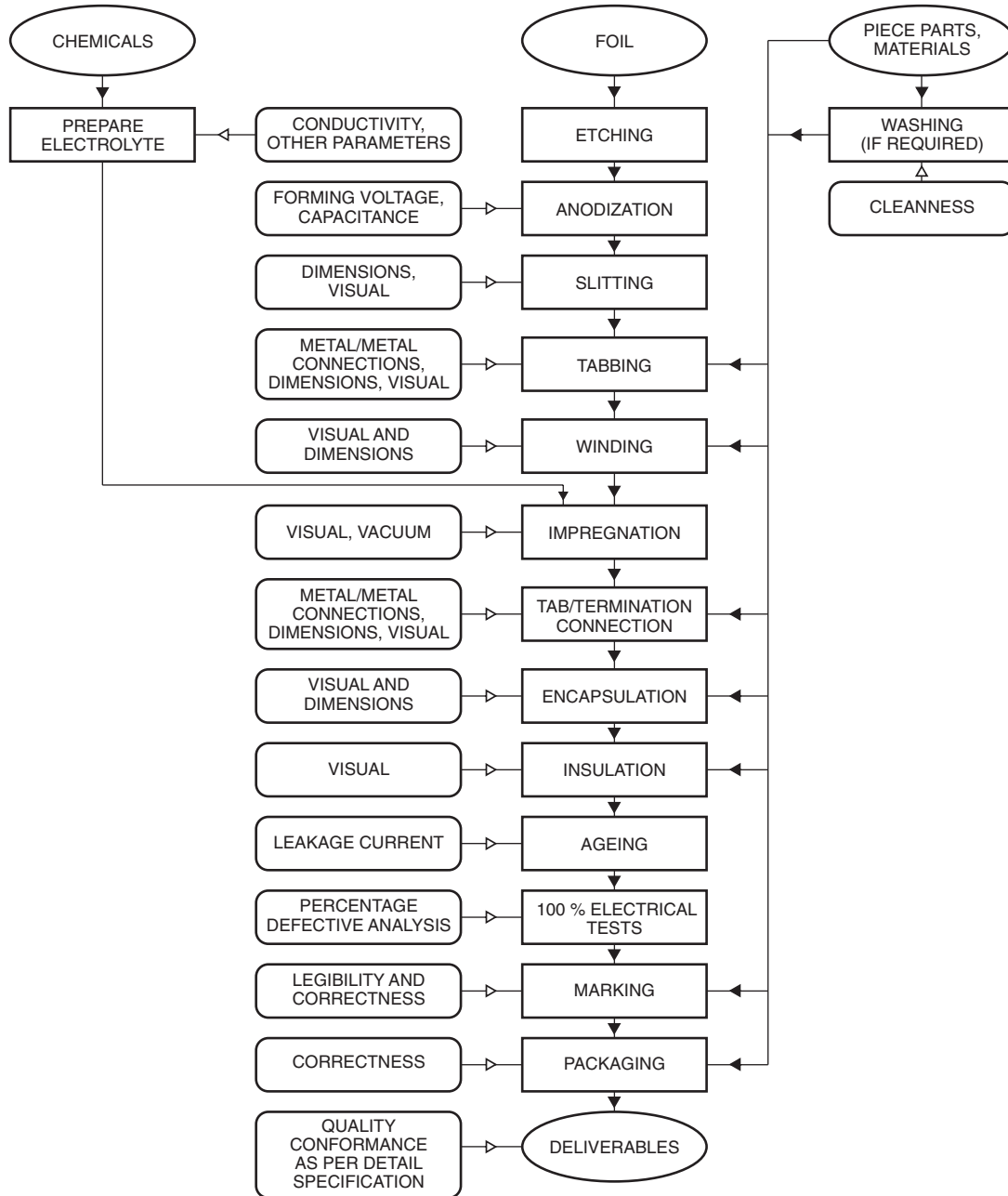
For a non-catalogue component, a.k.a. "special", the digits for Group 5 are sequential numbers.

Group 6

This group consists of 2 alphanumeric characters, positions 13 to 14. It enables to differentiate, between a lead (Pb)-free, RoHS compliant version and non lead (Pb)-free, non RoHS compliant version, when both could exist. It can have following values:

	Non lead (Pb)-free, non RoHS compliant product
E3	Lead (Pb)-free, RoHS compliant product.
E6	Lead (Pb)-free, RoHS compliant product. Bismuth, Bi, containing solder finish.

Generic Quality Flowchart for Non-Solid Electrolytic Capacitors



Layout and wording are based on CECC 210 011 (Technology Approval Schedule Electrolytic Capacitors).

Aluminum Capacitors Power Miniaturized General Purpose Snap-In

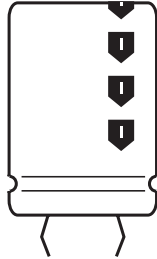
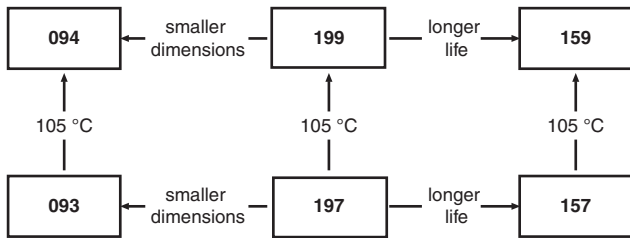


Fig.1 Component outlines



QUICK REFERENCE DATA	
DESCRIPTION	VALUE
Nominal case size (∅ D x L in mm)	22 x 25 to 35 x 50
Rated capacitance range, C _R	68 μF to 2200 μF
Tolerance on C _R	± 20 %
Rated voltage range, U _R	200 V to 450 V
Category temperature range	- 25 °C to + 85 °C
Useful life at 85 °C	2000 hours
Useful life at 40 °C and 1.4 x I _R applied	36 000 hours
Shelf life at 0 V, 85 °C	500 hours
Based on sectional specification	IEC 60384-4/EN130300/W of JISC5141

FEATURES

- Polarized aluminum electrolytic capacitors, non-solid electrolyte
- Large types, miniaturized dimensions, cylindrical aluminum case insulated with a blue sleeve
- Useful life: 2000 hours at 85 °C



RoHS
COMPLIANT

APPLICATIONS

- Consumer electronics
- Whitegood motor control
- Electronic drives
- Smps/ups

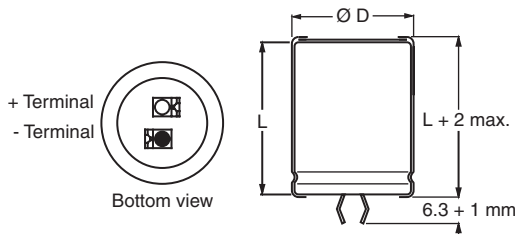
MARKING

The capacitors are marked (where possible) with the following information:

- Rated capacitance (in μF)
- Tolerance on rated capacitance, code letter in accordance with IEC 60062 (M for ± 20 %)
- Rated voltage (in V)
- Date code
- Name of manufacturer
- '-' sign to identify the negative terminal, visible from the top and side of the capacitor
- Code number (last 8 digits)
- Maximum operating temperature

SELECTION CHART FOR C _R , U _R AND RELEVANT NOMINAL CASE SIZES (∅ D x L in mm)					
C _R (μF)	U _R (V)				
	200	250	400	420	450
68	-	-	22 x 25	-	-
82	-	-	-	-	22 x 25
100	-	-	22 x 25	22 x 25	22 x 30
120	-	-	-	-	22 x 30 25 x 25
150	-	-	22 x 30 25 x 25	-	22 x 35
180	-	-	22 x 35 25 x 30	22 x 35 25 x 30	22 x 40 25 x 30 30 x 25
220	-	22 x 25	22 x 40 25 x 30 30 x 25	25 x 35 30 x 25	22 x 50 25 x 35 30 x 25
270	22 x 25	22 x 30	22 x 50 30 x 25	22 x 50 30 x 30	30 x 30 35 x 25

SELECTION CHART FOR C_R, U_R AND RELEVANT NOMINAL CASE SIZES (∅ D x L in mm)					
C _R (μF)	U _R (V)				
	200	250	400	420	450
330	-	22 x 35	25 x 40 30 x 30 35 x 25	25 x 50 30 x 35	25 x 50 35 x 30
390	22 x 30 25 x 25	22 x 35 25 x 30	25 x 50 30 x 35 35 x 30	35 x 30	30 x 40 35 x 35
470	22 x 35	25 x 35	30 x 40 35 x 30	35 x 35	35 x 40
560	25 x 30	25 x 40	30 x 45 35 x 35	30 x 50 35 x 40	35 x 45
680	25 x 35	30 x 30	35 x 40	35 x 45	35 x 50
820	25 x 40	30 x 35	35 x 50	-	-
1000	30 x 35	30 x 40	-	-	-
1200	30 x 40	35 x 40	-	-	-
1500	30 x 45	35 x 45	-	-	-
1800	30 x 50 35 x 40	35 x 50	-	-	-
2200	35 x 45	-	-	-	-

DIMENSIONS in millimeters AND AVAILABLE FORMS


The minus and/or plus terminal can be marked with an imprinted sign

Fig.2 Two terminal snap-in

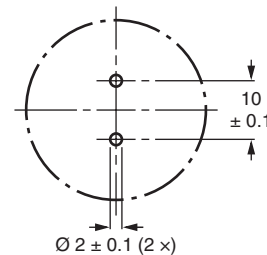


Fig.3 Mounting hole diagram

Table 1

DIMENSIONS in millimeters, MASS AND PACKAGING QUANTITIES					
NOMINAL CASE SIZE ∅ D x L	∅ D _{max.}	L _{max.}	MASS (g)	PACKAGING QUANTITIES	CARDBOARD BOX DIMENSIONS L x W x H
22 x 25	22.5	25.5	≈ 12	216	280 x 240 x 140
22 x 30	22.5	30.5	≈ 16	216	280 x 240 x 140
22 x 35	22.5	35.5	≈ 20	144	280 x 240 x 105
22 x 40	22.5	40.5	≈ 23	144	280 x 240 x 105
22 x 45	22.5	45.5	≈ 26	144	280 x 240 x 140
22 x 50	22.5	50.5	≈ 29	72	280 x 240 x 105
25 x 25	25.5	25.5	≈ 20	216	280 x 240 x 140
25 x 30	25.5	32.0	≈ 22	216	280 x 240 x 140
25 x 35	25.5	35.5	≈ 24	144	280 x 240 x 105
25 x 40	25.5	40.5	≈ 27	144	280 x 240 x 105
25 x 45	25.5	45.5	≈ 32	144	280 x 240 x 140
25 x 50	25.5	50.5	≈ 38	144	280 x 240 x 140
30 x 25	30.5	27.5	≈ 25	168	280 x 240 x 140
30 x 30	30.5	32.5	≈ 30	168	280 x 240 x 140
30 x 35	30.5	37.5	≈ 35	112	280 x 240 x 105
30 x 40	30.5	41.5	≈ 40	112	280 x 240 x 105
30 x 45	30.5	46.5	≈ 45	112	280 x 240 x 140
30 x 50	30.5	51.5	≈ 50	112	280 x 240 x 140
35 x 25	35.5	25.5	≈ 33	126	280 x 240 x 140
35 x 30	35.5	32.5	≈ 40	126	280 x 240 x 140
35 x 35	35.5	35.5	≈ 48	84	280 x 240 x 105
35 x 40	35.5	41.5	≈ 55	84	280 x 240 x 105
35 x 45	35.5	46.5	≈ 63	84	280 x 240 x 140
35 x 50	35.5	51.5	≈ 72	84	280 x 240 x 140

ELECTRICAL DATA	
SYMBOL	DESCRIPTION
C_R	rated capacitance at 120 Hz
I_R	rated RMS ripple current at 120 Hz, 85 °C
I_{L5}	max. leakage current after 5 minutes at U_R
ESR	max. equivalent series resistance at 120 Hz ⁽¹⁾

Notes

⁽¹⁾ ESR at 100 Hz is approximately 1.05 x ESR 120 Hz

- Unless otherwise specified, all electrical values in table 2 apply at $T_{amb} = 20\text{ °C}$, $P = 86\text{ kPa}$ to 106 kPa , $RH = 45\%$ to 75%

Table 2

ELECTRICAL DATA AND ORDERING INFORMATION							
U_R (V)	C_R 120 Hz (μF)	NOMINAL CASE SIZE $\varnothing D \times L$ (mm)	I_R 120 Hz (A)	I_{L5} (mA)	MAX. ESR ⁽¹⁾ 120 Hz (Ω)	MAX. Z 10 kHz (Ω)	ORDERING CODE MAL2093.....
200	270	22 x 25	1.26	1.08	0.47	0.31	52271E3
	390	22 x 30	1.55	1.50	0.33	0.22	52391E3
	390	25 x 25	1.46	1.50	0.36	0.25	42391E3
	470	22 x 35	1.78	1.50	0.27	0.18	52471E3
	560	25 x 30	1.83	1.50	0.25	0.17	42561E3
	680	25 x 35	2.06	1.50	0.21	0.15	42681E3
	820	25 x 40	2.36	1.50	0.18	0.12	42821E3
	1000	30 x 35	2.35	1.50	0.18	0.13	32102E3
	1200	30 x 40	2.69	1.50	0.15	0.11	32122E3
	1500	30 x 45	3.00	1.50	0.12	0.09	32152E3
	1800	30 x 50	3.36	1.50	0.11	0.08	32182E3
	1800	35 x 40	2.91	1.50	0.14	0.10	22182E3
	2200	35 x 45	3.23	1.50	0.12	0.09	22222E3
250	220	22 x 25	1.18	1.10	0.50	0.32	53221E3
	270	22 x 30	1.37	1.35	0.40	0.25	53271E3
	330	22 x 35	1.58	1.50	0.32	0.20	53331E3
	390	22 x 35	1.67	1.50	0.29	0.18	53391E3
	390	25 x 30	1.64	1.50	0.29	0.19	43391E3
	470	25 x 35	1.85	1.50	0.25	0.16	43471E3
	560	25 x 40	2.11	1.50	0.21	0.14	43561E3
	680	30 x 30	2.01	1.50	0.22	0.15	33681E3
	820	30 x 35	2.23	1.50	0.19	0.13	33821E3
	1000	30 x 40	2.56	1.50	0.15	0.11	33102E3
	1200	35 x 40	3.82	1.50	0.15	0.11	23122E3
	1500	35 x 45	3.08	1.50	0.13	0.09	23152E3
	1800	35 x 50	3.35	1.50	0.11	0.08	23182E3
400	68	22 x 25	0.80	0.54	2.06	1.49	56689E3
	100	22 x 25	0.98	0.80	1.48	1.09	56101E3
	150	22 x 30	1.11	1.20	1.00	0.74	56151E3
	150	25 x 25	1.10	1.20	1.03	0.77	46151E3
	180	22 x 35	1.26	1.44	0.83	0.61	56181E3
	180	25 x 30	1.27	1.44	0.81	0.59	46181E3
	220	22 x 40	1.46	1.50	0.68	0.50	56221E3
	220	25 x 30	1.38	1.50	0.70	0.52	46221E3
	220	30 x 25	1.43	1.50	0.71	0.53	36221E3
	270	22 x 50	1.58	1.50	0.53	0.39	56271E3
	270	30 x 25	1.53	1.50	0.63	0.48	36271E3
	330	25 x 40	1.82	1.50	0.49	0.37	46331E3
	330	30 x 30	1.77	1.50	0.50	0.39	36331E3
	330	35 x 25	1.77	1.50	0.58	0.46	26331E3
	390	25 x 50	2.21	1.50	0.40	0.30	46391E3
	390	30 x 35	1.98	1.50	0.43	0.33	36391E3
	390	35 x 30	2.10	1.50	0.44	0.34	26391E3
	470	30 x 40	2.20	1.50	0.37	0.28	36471E3
	470	35 x 30	2.14	1.50	0.40	0.32	26471E3
	560	30 x 45	2.48	1.50	0.30	0.23	36561E3
	560	35 x 35	2.35	1.50	0.34	0.27	26561E3
	680	35 x 40	2.68	1.50	0.28	0.22	26681E3
820	35 x 50	3.18	1.50	0.22	0.17	26821E3	

ORDERING EXAMPLE

Electrolytic capacitor 093 series

330 μF /400 V; $\pm 20\%$

Nominal case size: $\varnothing 25 \times 40\text{ mm}$

2-terminal snap-in:

Ordering code: MAL209346331E3

Former 12NC: 222209346331



Aluminum Capacitors
Power Miniaturized General Purpose Snap-In

Vishay BCcomponents

ELECTRICAL DATA AND ORDERING INFORMATION							
U _R (V)	C _R 120 Hz (μF)	NOMINAL CASE SIZE Ø D x L (mm)	I _R 120 Hz (A)	I _{L5} (mA)	MAX. ESR ⁽¹⁾ 120 Hz (Ω)	MAX. Z 10 kHz (Ω)	ORDERING CODE MAL2093.....
420	100	22 x 25	0.89	0.84	1.44	1.05	54101E3
	180	22 x 35	1.29	1.50	0.81	0.59	54181E3
	180	25 x 30	1.29	1.50	0.78	0.57	44181E3
	220	25 x 35	1.47	1.50	0.67	0.50	44221E3
	220	30 x 25	1.44	1.50	0.69	0.52	34221E3
	270	22 x 50	1.61	1.50	0.54	0.39	54271E3
	270	30 x 30	1.67	1.50	0.56	0.41	34271E3
	330	25 x 50	1.47	1.50	0.43	0.31	44331E3
	330	30 x 35	1.88	1.50	0.46	0.35	34331E3
	390	35 x 30	2.05	1.50	0.47	0.37	24391E3
	470	35 x 35	2.27	1.50	0.37	0.28	24471E3
	560	30 x 50	2.66	1.50	0.31	0.25	34561E3
	560	35 x 40	2.57	1.50	0.34	0.27	24561E3
	680	35 x 45	2.87	1.50	0.28	0.23	24681E3
450	82	22 x 25	0.80	0.74	1.77	1.31	57829E3
	100	22 x 30	0.95	0.90	1.45	1.07	57101E3
	120	22 x 30	1.00	1.08	1.26	0.95	57121E3
	120	25 x 25	1.00	1.08	1.29	0.97	47121E3
	150	22 x 35	1.17	1.35	1.01	0.76	57151E3
	180	22 x 40	1.34	1.50	0.85	0.63	57181E3
	180	25 x 30	1.27	1.50	0.86	0.65	47181E3
	180	30 x 25	1.32	1.50	0.86	0.65	37181E3
	220	22 x 50	1.45	1.50	0.66	0.49	57221E3
	220	25 x 35	1.45	1.50	0.73	0.56	47221E3
	220	30 x 25	1.42	1.50	0.76	0.59	37221E3
	270	30 x 30	1.64	1.50	0.61	0.47	37271E3
	270	35 x 25	1.66	1.50	0.68	0.54	27271E3
	330	25 x 50	2.07	1.50	0.46	0.35	47331E3
	330	35 x 30	1.98	1.50	0.50	0.39	27331E3
	390	30 x 40	2.11	1.50	0.42	0.32	37391E3
	390	35 x 35	2.18	1.50	0.43	0.33	27391E3
	470	35 x 40	2.47	1.50	0.35	0.27	27471E3
	560	35 x 45	2.74	1.50	0.30	0.23	27561E3
	680	35 x 50	3.07	1.50	0.25	0.20	27681E3

Note

⁽¹⁾ ESR at 100 Hz is approximately 1.05 x ESR 120 Hz

ADDITIONAL ELECTRICAL DATA		
PARAMETER	CONDITIONS	VALUE
Voltage		
Surge voltage	≥ 200 V versions	U _S = 1.1 x U _R
Reverse voltage	≤ 1 V	-
Current		
Leakage current	After 5 minutes at U _R	I _{L5} ≤ 0.02 C _R x U _R or 1.5 mA, whichever is smaller
Inductance		
Equivalent series inductance (ESL)	All case sizes	19 nH typical/25 nH max.

Table 3

LOW TEMPERATURE CHARACTERISTIC (at 120 Hz)		
DESCRIPTION	U _R (V) ⁽¹⁾	
	200 to 450	
Impedance ratio	Z (- 25 °C)/Z (+ 20 °C)	4

Note

⁽¹⁾ Impedance ratio shall not exceed the given values



RIPPLE CURRENT AND USEFUL LIFE

I_A = actual ripple current at 120 Hz
 I_R = rated ripple current at 120 Hz and 85 °C
 (1) Useful life at 85 °C and I_R applied: 2000 hours

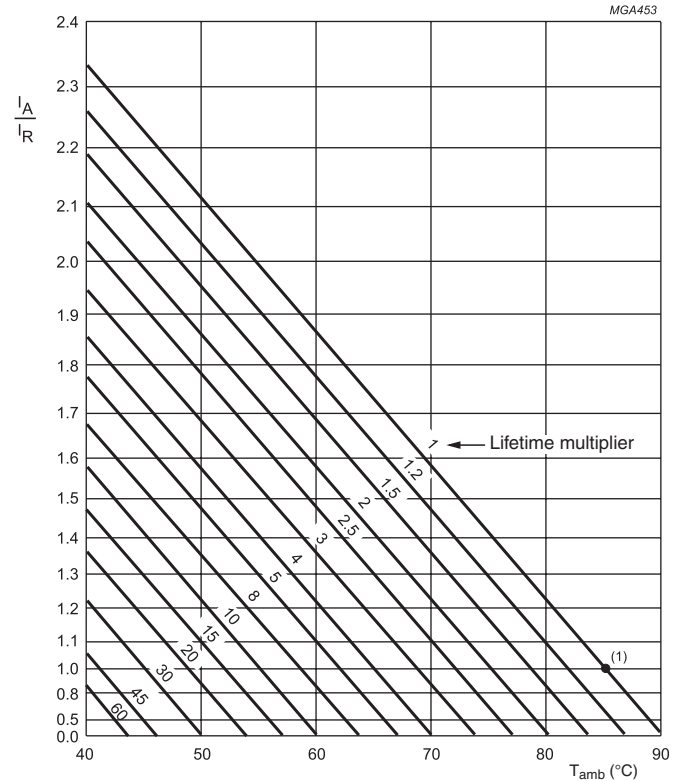


Fig.4 Multiplier of useful life as a function of ambient temperature and ripple current load

Table 4

MULTIPLIER OF RIPPLE CURRENT (I_R) AS A FUNCTION OF FREQUENCY	
FREQUENCY (Hz)	I_R MULTIPLIER 400 V and 450 V
60	0.90
100	0.95
120	1.00
500	1.20
1000	1.30
$\geq 10\ 000$	1.40

Table 5

TEST PROCEDURES AND REQUIREMENTS			
TEST		PROCEDURE (quick reference)	REQUIREMENTS
NAME OF TEST	REFERENCE		
Useful life	CECC 30301 subclause 1.8.1	$T_{amb} = 85\ ^\circ\text{C}$; U_R and I_R applied: 2000 hours	$\Delta C/C: \pm 30\ \%$ ESR $\leq 3 \times$ spec. limit $I_{L5} \leq$ spec. limit no short or open circuit, no visible damage total failure percentage: $\leq 3\ \%$
Shelf life (storage at high temperature)	IEC 60384-4/ EN130300 subclause 4.17	$T_{amb} = 85\ ^\circ\text{C}$; no voltage applied; 500 hours After test: U_R to be applied for 30 minutes, 24 hours to 48 hours before measurement	$\Delta C/C: \pm 20\ \%$ ESR $\leq 2 \times$ spec. limit $I_{L5} \leq 1 \times$ spec. limit

Aluminum Capacitors Power Ultra Miniature Snap-In

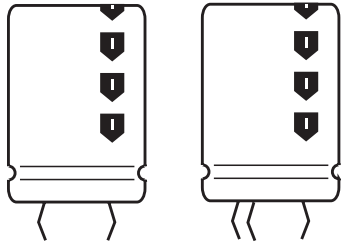


Fig.1 Component outline



QUICK REFERENCE DATA	
DESCRIPTION	VALUE
Nominal case size (\varnothing D x L in mm)	22 x 25 to 35 x 60
Rated capacitance range (E6 series), C_R	1000 μ F to 22 000 μ F
Tolerance on C_R	\pm 20 %
Rated voltage range, U_R	10 V to 100 V
Category temperature range	- 40 °C to + 85 °C
Endurance test at 85 °C	2000 hours
Useful life at 85 °C	5000 hours
Useful life at 40 °C and 1.4 x I_R applied	90 000 hours
Shelf life at 0 V, 85 °C	500 hours
Based on sectional specification	IEC 60384-4/EN130300
Climatic category IEC 60068	40/085/56

FEATURES

- Polarized aluminum electrolytic capacitors, non-solid electrolyte
- Large types, very small dimensions, cylindrical aluminum case, insulated with a blue sleeve
- Charge and discharge proof
- Long useful life: 5000 hours at 85 °C
- High ripple current capability
- Keyed polarity version available


**RoHS
COMPLIANT**
APPLICATIONS

- General purpose, industrial and audio/video systems
- Smoothing and filtering
- Standard and switched mode power supplies
- Energy storage in pulse systems

MARKING

The capacitors are marked (where possible) with the following information:

- Rated capacitance (in μ F)
- Tolerance code on rated capacitance, code letter in accordance with IEC 60062 (M for \pm 20 %)
- Rated voltage (in V)
- Date code (YYMM)
- Name of manufacturer
- Code for factory of origin
- '-' sign to identify the negative terminal, visible from the top and side of the capacitor
- Code number
- Climatic category in accordance with IEC 60068

SELECTION CHART FOR C_R , U_R AND RELEVANT NOMINAL CASE SIZES (\varnothing D x L in mm)

C_R (μ F)	U_R (V)						
	16	25	40	50	63	80	100
1000	-	-	-	-	-	-	22 x 30
1200	-	-	-	-	-	-	22 x 35
1500	-	-	-	-	22 x 25	22 x 30	25 x 30
1800	-	-	-	-	25 x 25	-	-
2200	-	-	-	22 x 25	22 x 30	25 x 30	25 x 40
	-	-	-	-	25 x 25	-	30 x 30
2700	-	-	22 x 25	-	25 x 30	-	30 x 35
	-	-	22 x 30	22 x 30	25 x 35	25 x 40	30 x 40
3300	-	-	25 x 25	-	-	-	35 x 30
	-	-	-	25 x 30	25 x 40	-	-
4700	-	-	25 x 30	25 x 35	22 x 50	30 x 40	30 x 50
	-	22 x 25	-	-	30 x 30	-	35 x 40
5600	-	25 x 25	-	25 x 40	30 x 35	-	-
6800	-	-	25 x 40	30 x 30	30 x 40	30 x 50	35 x 50
8200	-	-	30 x 30	30 x 35	30 x 50	-	35 x 60
10 000	25 x 30	22 x 40	30 x 35	30 x 40	35 x 40	35 x 50	-
12 000	-	25 x 40	30 x 40	30 x 50	35 x 50	-	-
15 000	25 x 40	30 x 35	30 x 50	-	35 x 60	-	-
	30 x 30	-	-	-	-	-	-
18 000	-	30 x 40	35 x 40	35 x 50	-	-	-
22 000	30 x 35	-	35 x 50	35 x 60	-	-	-
27 000	-	35 x 40	-	-	-	-	-
39 000	35 x 40	-	-	-	-	-	-

DIMENSIONS in millimeters **AND AVAILABLE FORMS**

TWO TERMINAL SNAP-IN

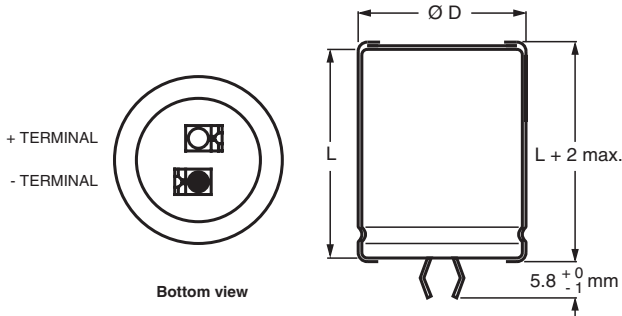


Fig.2 Two terminal snap-in

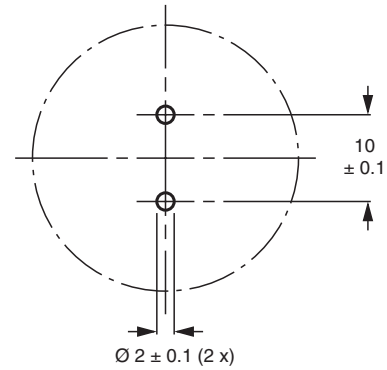


Fig.3 Mounting hole diagram

The minus terminal can be marked with a black dot or with an imprinted '-' sign.

THREE TERMINAL SNAP-IN

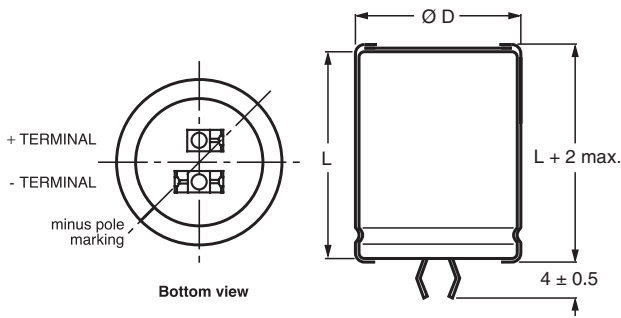


Fig.4 Three terminal snap-in

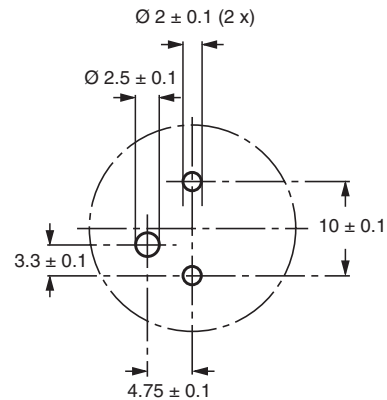


Fig.5 Mounting hole diagram

The negative terminal has **TWO** pins which are **BOTH** electrically connected.

The 10 mm spacing of the 2 pin snap-in is used as the base layout and a third hole is added.

The third hole is closer to the negative primary hole so that polarization is always maintained, together with added mechanical stability.



Table 1

DIMENSIONS in millimeters, MASS AND PACKAGING QUANTITIES					
NOMINAL CASE SIZE Ø D x L	Ø D _{max.} (mm)	L _{max.} (mm)	MASS (g)	PACKAGING QUANTITIES (units per box)	CARDBOARD BOX DIMENSIONS L x W x H
22 x 25	23	27	≈ 12	100	260 x 250 x 39
22 x 30	23	32	≈ 16	100	260 x 250 x 44
22 x 35	23	37	≈ 20	100	260 x 250 x 49
22 x 40	23	42	≈ 23	100	260 x 250 x 54
22 x 50	23	52	≈ 29	100	260 x 250 x 64
25 x 25	26	27	≈ 20	100	290 x 280 x 39
25 x 30	26	32	≈ 22	100	290 x 280 x 44
25 x 35	26	37	≈ 24	100	290 x 280 x 49
25 x 40	26	42	≈ 27	100	290 x 280 x 54
30 x 30	31	32	≈ 30	100	340 x 330 x 44
30 x 35	31	37	≈ 35	100	340 x 330 x 49
30 x 40	31	42	≈ 42	100	340 x 330 x 54
30 x 50	31	52	≈ 52	100	340 x 330 x 64
35 x 30	36	32	≈ 40	50	390 x 198 x 44
35 x 40	36	42	≈ 55	50	390 x 198 x 54
35 x 50	36	52	≈ 72	50	390 x 198 x 64
35 x 60	36	62	≈ 84	50	390 x 198 x 74

ELECTRICAL DATA	
SYMBOL	DESCRIPTION
C _R	rated capacitance at 100 Hz
I _R	rated RMS ripple current at 100 Hz and 85 °C
I _{L1}	max. leakage current after 1 minute at U _R
ESR	max. equivalent series resistance at 100 Hz
Z	max. impedance at 10 kHz

Note

- Unless otherwise specified, all electrical values in table 2 apply at T_{amb} = 20 °C, P = 86 kPa to 106 kPa, RH = 45 % to 75 %

ORDERING EXAMPLE

Electrolytic capacitor 156 series
 1000 µF/25 V; ± 20 %
 Nominal case size: Ø 25 x 40 mm
 2-terminal snap-in:
 Ordering code: MAL2 15626123E3
 Former 12NC: 2222 15626123
 3-terminal snap-in:
 Ordering code: MAL2 15666123E3
 Former 12NC: 2222 15666123

Table 2

ELECTRICAL DATA AND ORDERING INFORMATION								
U _R (V)	C _R 100 Hz (µF)	NOMINAL CASE SIZE Ø D x L (mm)	I _R 100 Hz 85 °C (A)	I _{L5} 5 min (µA)	MAX. ESR 100 Hz (mΩ)	MAX. Z 10 kHz (mΩ)	ORDERING CODE MAL2156.....	
							2-TERM.	3-TERM.
16	10 000	25 x 30	3.93	324	49	33	25103E3	65103E3
	15 000	25 x 40	4.98	484	36	26	35153E3	75153E3
	18 000	30 x 30	4.12	580	53	33	35183E3	75183E3
	22 000	30 x 35	4.71	708	44	29	25223E3	65223E3
	39 000	35 x 40	5.17	1252	45	26	25393E3	65393E3
25	4700	22 x 25	2.37	239	100	90	16472E3	56472E3
	5600	25 x 25	3.03	284	74	46	26562E3	66562E3
	10 000	22 x 40	4.40	504	41	27	16103E3	56103E3
	12 000	25 x 40	4.73	604	40	27	26123E3	66123E3
	15 000	30 x 35	4.55	754	47	31	26153E3	66153E3
	18 000	30 x 40	5.06	904	41	27	16183E3	56183E3
	27 000	35 x 40	5.04	1354	47	27	26273E3	66273E3



ELECTRICAL DATA AND ORDERING INFORMATION								
U _R (V)	C _R 100 Hz (μF)	NOMINAL CASE SIZE Ø D x L (mm)	I _R 100 Hz 85 °C (A)	I _{L5} 5 min (μA)	MAX. ESR 100 Hz (mΩ)	MAX. Z 10 kHz (mΩ)	ORDERING CODE MAL2156.....	
							2-TERM.	3-TERM.
40	2700	22 x 25	2.47	220	97	57	17272E3	57272E3
	3300	22 x 30	2.98	268	74	43	27332E3	67332E3
	3300	25 x 25	2.69	268	93	58	17332E3	57332E3
	4700	25 x 30	3.32	380	68	44	27472E3	67472E3
	6800	25 x 40	4.26	548	49	33	37682E3	77682E3
	8200	30 x 30	3.49	660	74	44	37822E3	77822E3
	10 000	30 x 35	4.02	804	60	38	17103E3	57103E3
	12 000	30 x 40	4.49	964	52	33	17123E3	57123E3
	15 000	30 x 50	5.39	1204	41	28	37153E3	77153E3
	18 000	35 x 40	4.39	1444	62	33	17183E3	57183E3
22 000	35 x 50	5.34	1764	47	28	27223E3	67223E3	
50	2200	22 x 25	2.34	224	107	62	11222E3	51222E3
	3300	22 x 30	2.92	334	76	46	11332E3	51332E3
	3900	25 x 30	3.17	394	74	47	21392E3	61392E3
	4700	25 x 35	3.64	474	62	40	21472E3	61472E3
	5600	25 x 40	4.09	564	53	35	21562E3	61562E3
	6800	30 x 30	3.35	684	79	48	21682E3	61682E3
	8200	30 x 35	3.88	824	65	40	21822E3	61822E3
	10 000	30 x 40	4.32	1004	56	35	11103E3	51103E3
	12 000	30 x 50	5.23	1204	43	29	11123E3	51123E3
	18 000	35 x 50	5.18	1804	50	29	11183E3	51183E3
22 000	35 x 60	5.97	2204	51	46	11223E3	51223E3	
63	1500	22 x 25	2.13	193	128	68	18152E3	58152E3
	1800	25 x 25	2.37	231	120	69	18182E3	58182E3
	2200	22 x 30	2.66	281	92	50	18222E3	58222E3
	2200	25 x 25	2.42	281	115	70	28222E3	68222E3
	2700	25 x 30	2.95	344	86	51	28272E3	68272E3
	3300	25 x 35	3.39	420	71	43	28332E3	68332E3
	3900	25 x 40	3.81	495	61	37	28392E3	68392E3
	4700	22 x 50	4.26	596	50	30	18472E3	58472E3
	4700	30 x 30	3.25	596	85	53	38472E3	78472E3
	5600	30 x 35	3.75	710	69	45	28562E3	68562E3
	6800	30 x 40	4.19	861	59	39	18682E3	58682E3
	6800	35 x 30	3.28	861	97	53	28682E3	68682E3
	8200	30 x 50	5.05	1037	46	32	38822E3	78822E3
	10 000	35 x 40	4.23	1264	67	39	18103E3	58103E3
12 000	35 x 50	5.15	1516	51	32	18123E3	58123E3	
15 000	35 x 60	5.89	1894	52	47	18153E3	58153E3	
80	1500	22 x 30	1.83	244	318	308	12152E3	52152E3
	2200	25 x 30	2.23	356	230	224	22222E3	62222E3
	3300	25 x 40	2.92	532	155	152	22332E3	62332E3
	4700	30 x 40	3.44	756	121	119	12472E3	52472E3
	6800	30 x 50	4.18	1092	88	87	12682E3	52682E3
	10 000	35 x 50	4.51	1604	74	73	12103E3	52103E3
100	1000	22 x 30	1.72	204	338	312	19102E3	59102E3
	1200	22 x 35	1.98	244	282	261	29122E3	59122E3
	1500	25 x 30	2.12	304	239	223	29152E3	59152E3
	2200	25 x 40	2.77	444	164	154	29222E3	59222E3
	2200	30 x 30	2.55	444	181	171	39222E3	79222E3
	2700	30 x 35	2.94	544	148	140	29272E3	69272E3
	3300	30 x 40	3.32	664	123	116	19332E3	59332E3
	3300	35 x 30	2.84	664	147	140	29332E3	69332E3
	4700	30 x 50	4.04	944	90	86	19472E3	59472E3
	4700	35 x 40	3.67	944	102	98	29472E3	69472E3
	6800	35 x 50	4.39	1364	76	73	19682E3	59682E3
	8200	35 x 60	5.21	1644	63	61	19822E3	59822E3



ADDITIONAL ELECTRICAL DATA		
PARAMETER	CONDITIONS	VALUE
Voltage		
Surge voltage		$U_s = 1.15 \times U_R$
Reverse voltage		$U_{rev} \leq 1 \text{ V}$
Current		
Leakage current	After 1 minute at U_R	$I_{L1} \leq 0.006 C_R \times U_R + 4 \mu\text{A}$
	After 5 minutes at U_R	$I_{L5} \leq 0.002 C_R \times U_R + 4 \mu\text{A}$
Inductance		
Equivalent series inductance (ESL)	All case sizes	typ. 19 nH
		max. 25 nH

RIPPLE CURRENT AND USEFUL LIFE

MGA453

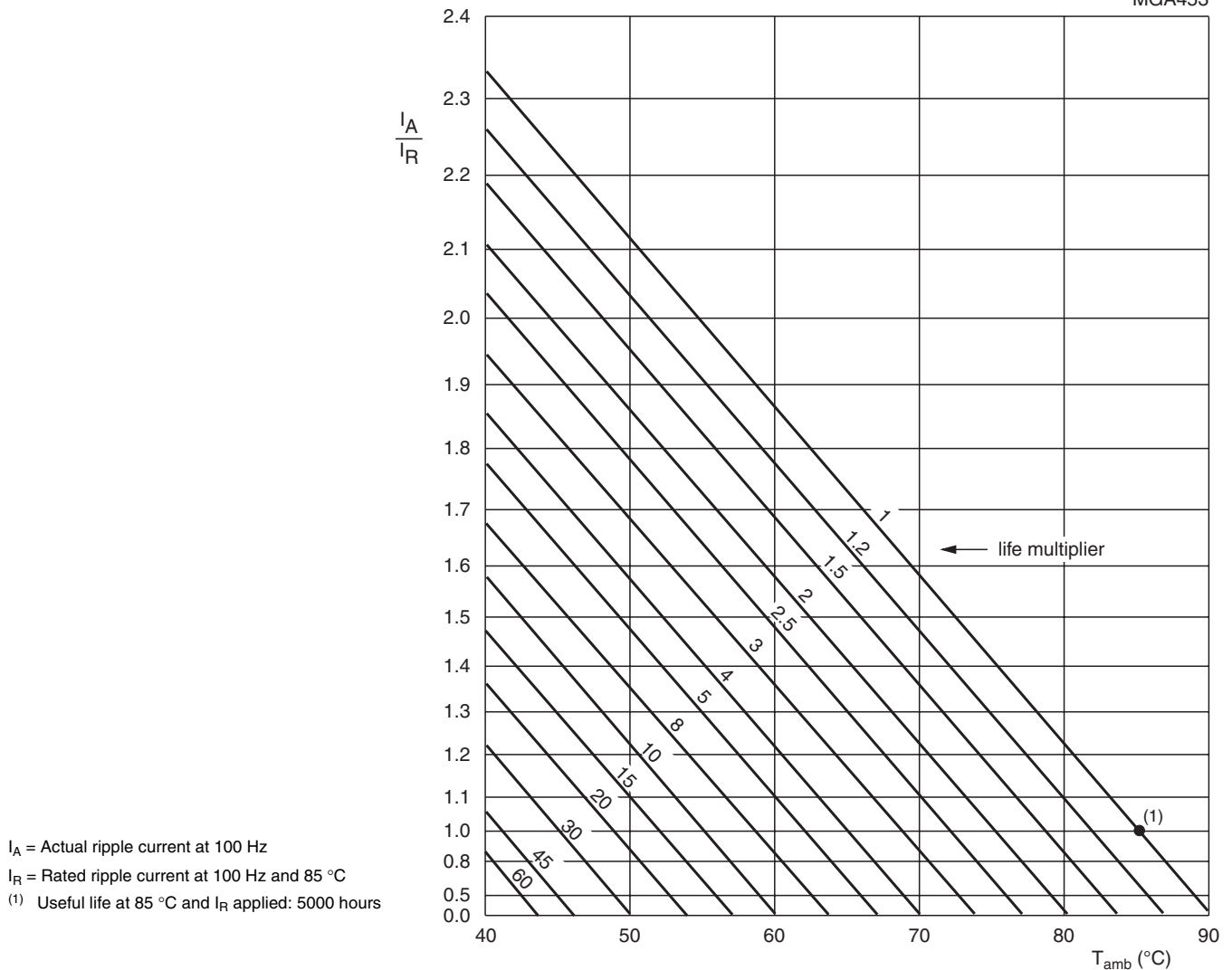


Fig.6 Multiplier of useful life as a function of ambient temperature and ripple current load

Table 3

MULTIPLIER OF RIPPLE CURRENT (I_R) AS A FUNCTION OF FREQUENCY		
FREQUENCY (Hz)	I_R MULTIPLIER	
	$U_R = 10\text{ V to }25\text{ V}$	$U_R = 40\text{ V to }100\text{ V}$
50	0.93	0.91
100	1.00	1.00
200	1.04	1.05
400	1.07	1.09
1000	1.11	1.13
2000	1.13	1.15
4000	1.15	1.18
$\geq 10\ 000$	1.18	1.22

Table 4

TEST PROCEDURES AND REQUIREMENTS			
TEST		PROCEDURE (quick reference)	REQUIREMENTS
NAME OF TEST	REFERENCE		
Endurance	IEC 60384-4/ EN130300 subclause 4.13	$T_{amb} = 85\text{ }^\circ\text{C}$; U_R applied: 2000 hours	$\Delta C/C: \pm 15\%$ $ESR \leq 1.3 \times \text{spec. limit}$ $Z \leq 2 \times \text{spec. limit}$ $I_{L5} \leq \text{spec. limit}$
Useful life	CECC 30301 subclause 1.8.1	$T_{amb} = 85\text{ }^\circ\text{C}$; U_R and I_R applied: 5000 hours	$\Delta C/C: \pm 15\%$ $ESR \leq 3 \times \text{spec. limit}$ $Z \leq 3 \times \text{spec. limit}$ $I_{L5} \leq \text{spec. limit}$ no short or open circuit, no visible damage total failure percentage: $\leq 1\%$
Shelf life (storage at high temperature)	IEC 60384-4/ EN130300 subclause 4.17	$T_{amb} = 85\text{ }^\circ\text{C}$; no voltage applied; 500 hours After test: U_R to be applied for 30 minutes, 24 hours to 48 hours before measurement	$\Delta C/C: \pm 10\%$ $ESR \leq 1.2 \times \text{spec. limit}$ $I_{L5} \leq 2 \times \text{spec. limit}$

Aluminum Capacitors Power Ultra Miniature Snap-In

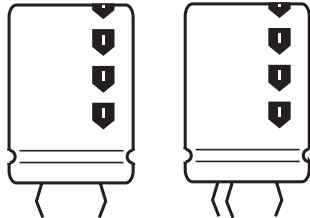
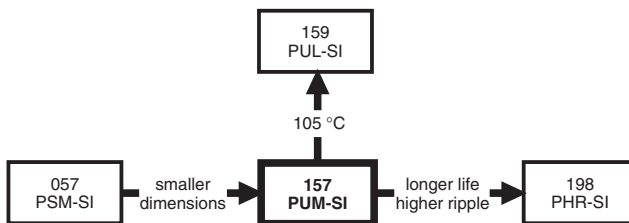


Fig.1 Component outlines


FEATURES

- Polarized aluminum electrolytic capacitors, non-solid electrolyte
- Large types, very small dimensions, cylindrical aluminum case, insulated with a blue sleeve
- Useful life: 5000 hours at 85 °C
- Keyed polarity version available


**RoHS
COMPLIANT**
APPLICATIONS

- General purpose, industrial and audio/video systems
- Smoothing and filtering
- Standard and switched mode power supplies
- Energy storage in pulse systems

MARKING

The capacitors are marked (where possible) with the following information:

- Rated capacitance (in μF)
- Tolerance on rated capacitance, code letter in accordance with IEC 60062 (M for $\pm 20\%$)
- Rated voltage (in V)
- Date code (YYMM)
- Name of manufacturer
- Code for factory of origin
- '-' sign to identify the negative terminal, visible from the top and side of the capacitor
- Code number, all 12 or last 8 digits (2222) 157 xxxxx
- Climatic category in accordance with IEC 60068

QUICK REFERENCE DATA

DESCRIPTION	VALUE
Nominal case sizes (\varnothing D x L in mm)	22 x 25 to 35 x 60
Rated capacitance range (E6/E12 series), C_R	56 μF to 2200 μF
Tolerance on C_R	$\pm 20\%$
Rated voltage range, U_R	200 V, 250 V 400 V, 450 V
Category temperature range	- 25 °C to + 85 °C
Endurance test at 85 °C	3000 hours
Load life at 85 °C	3000 hours
Useful life at 85 °C	5000 hours
Useful life at 40 °C, 1.4 x I_R applied	90 000 hours
Shelf life at 0 V, 85 °C	1000 hours
Based on sectional specification	IEC 60384-4/EN130300
Climatic category IEC 60038	25/085/56

SELECTION CHART FOR C_R , U_R AND RELEVANT NOMINAL CASE SIZES (\varnothing D x L in mm)

C_R (μF)	U_R (V)			
	200	250	400	450
56	-	-	-	22 x 25
68	-	-	22 x 25	22 x 30
82	-	-	22 x 25	22 x 30
	-	-	-	25 x 25
100	-	-	22 x 30	22 x 35
	-	-	-	25 x 30
120	-	-	22 x 30	22 x 40
	-	-	-	25 x 30
	-	-	-	30 x 25

SELECTION CHART FOR C_R, U_R AND RELEVANT NOMINAL CASE SIZES ($\varnothing D \times L$ in mm)				
C_R (μF)	U_R (V)			
	200	250	400	450
150	-	-	22 x 35	25 x 35
	-	-	25 x 30	25 x 40
	-	-	-	30 x 30
180	-	-	22 x 40	25 x 40
	-	-	25 x 35	30 x 35
	-	-	-	35 x 25
220	-	22 x 30	25 x 40	25 x 50
	-	-	30 x 30	30 x 40
	-	-	35 x 25	35 x 30
270	22 x 25	22 x 30	25 x 45	30 x 45
	-	25 x 25	30 x 35	35 x 35
	-	-	35 x 30	-
330	22 x 30	22 x 35	30 x 40	30 x 50
	-	25 x 30	35 x 30	35 x 40
390	22 x 30	22 x 40	30 x 45	35 x 45
	-	30 x 25	35 x 35	-
470	22 x 35	25 x 35	30 x 50	35 x 50
	25 x 30	30 x 30	35 x 40	-
560	22 x 40	25 x 40	35 x 45	-
	25 x 35	30 x 30	-	-
	30 x 25	35 x 25	-	-
680	25 x 40	25 x 45	35 x 50	35 x 60
	30 x 30	30 x 35	-	-
	35 x 25	35 x 30	-	-
820	25 x 45	30 x 40	35 x 60	-
	30 x 35	35 x 35	-	-
	35 x 30	-	-	-
1000	30 x 40	30 x 45	-	-
	35 x 30	35 x 40	-	-
1200	30 x 45	35 x 45	-	-
	35 x 35	-	-	-
1500	30 x 50	35 x 50	-	-
	35 x 40	-	-	-
1800	35 x 45	-	-	-
2200	35 x 50	-	-	-

DIMENSIONS in millimeters AND AVAILABLE FORMS

TWO TERMINAL SNAP-IN

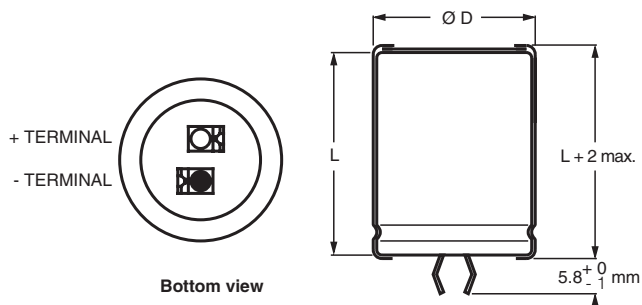


Fig.2 Two terminal snap-in

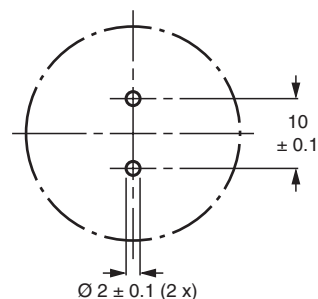
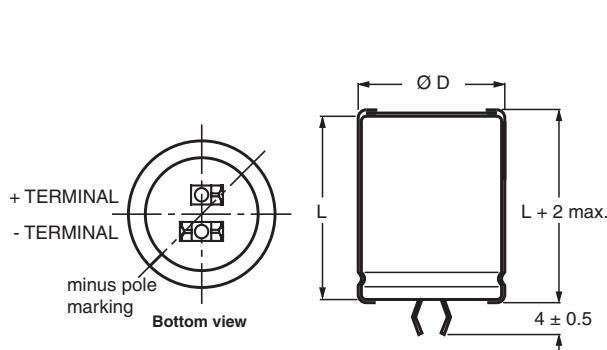


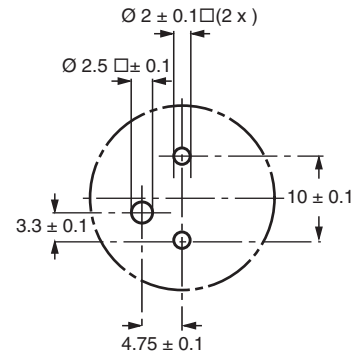
Fig.3 Mounting hole diagram

The minus terminal can be marked with a black dot or with an imprinted '-' sign.

THREE TERMINAL SNAP-IN


The negative terminal has **TWO** pins which are **BOTH** electrically connected.

Fig.4 Three terminal snap-in



The 10 mm spacing of the 2 pin snap-in is used as the base layout and a third hole is added. The third hole is closer to the negative primary hole so that polarization is always maintained, together with added mechanical stability.

Fig.5 Mounting hole diagram

Table 1

DIMENSIONS in millimeters, MASS AND PACKAGING QUANTITIES				
NOMINAL CASE SIZE $\varnothing D \times L$	$\varnothing D_{\text{max.}}$	$L_{\text{max.}}$	MASS (g)	PACKAGING QUANTITIES (units per box)
22 x 25	23	27	≈ 12	100
22 x 30	23	32	≈ 16	100
22 x 35	23	37	≈ 20	100
22 x 40	23	42	≈ 23	100
25 x 25	26	27	≈ 20	100
25 x 30	26	32	≈ 22	100
25 x 35	26	37	≈ 24	100
25 x 40	26	42	≈ 27	100
25 x 45	26	47	≈ 32	100
25 x 50	26	52	≈ 38	100
30 x 25	31	27	≈ 25	100
30 x 30	31	32	≈ 30	100
30 x 35	31	37	≈ 35	100
30 x 40	31	42	≈ 40	100
30 x 45	31	47	≈ 45	100
30 x 50	31	52	≈ 50	100
35 x 25	36	27	≈ 33	50
35 x 30	36	32	≈ 40	50
35 x 35	36	37	≈ 48	50
35 x 40	36	42	≈ 55	50
35 x 45	36	47	≈ 63	50
35 x 50	36	52	≈ 72	50
35 x 60	36	62	≈ 82	50



ELECTRICAL DATA	
SYMBOL	DESCRIPTION
C_R	rated capacitance at 100/120 Hz
I_R	rated RMS ripple current at 120 Hz, 85 °C
I_{L5}	max. leakage current after 5 minutes at U_R
ESR	typ./max. equivalent series resistance at 100 Hz ⁽¹⁾
Z	typ./max. impedance at 10 kHz

Notes

- ⁽¹⁾ ESR at 120 Hz is approximately 0.95 x ESR 100 Hz
- Unless otherwise specified, all electrical values in table 2 apply at $T_{amb} = 20\text{ °C}$, $P = 86\text{ kPa}$ to 106 kPa , $RH = 45\%$ to 75%

ORDERING EXAMPLE

Electrolytic capacitor 157 series
1000 $\mu\text{F}/200\text{ V}$; $\pm 20\%$
Nominal case size: $\varnothing 30 \times 40\text{ mm}$
2-terminal snap-in:
Ordering code: MAL2 157 52102 E3
Former 12NC: 2222 157 52102

3-terminal snap-in:
Ordering code: MAL2 157 72102 E3
Former 12NC: 2222 157 72102

Table 2

ELECTRICAL DATA AND ORDERING INFORMATION										
U_R (V)	C_R 100 Hz (μF)	NOMINAL CASE SIZE $\varnothing D \times L$ (mm)	I_R 120 Hz 85 °C (A)	I_{L5} 5 min (mA)	TYP. ESR 100 Hz ⁽¹⁾ (M Ω)	MAX. ESR 100 Hz ⁽¹⁾ (M Ω)	TYP. Z 10 kHz (M Ω)	MAX. Z 10 kHz (M Ω)	ORDERING CODE MAL2157.....	
									2-TERM.	3-TERM.
200	270	22 x 25	1.15	0.54	550	880	420	700	52271E3	72271E3
	330	22 x 30	1.36	0.66	430	720	300	500	52331E3	72331E3
	390	22 x 30	1.46	0.78	390	650	295	490	52391E3	72391E3
	470	22 x 35	1.68	0.94	350	580	240	400	32471E3	12471E3
	470	25 x 30	1.67	0.94	350	580	240	400	52471E3	72471E3
	560	22 x 40	1.91	1.12	255	425	235	390	42561E3	22561E3
	560	25 x 35	1.91	1.12	255	425	235	390	32561E3	12561E3
	560	30 x 25	1.89	1.12	255	425	235	390	52561E3	72561E3
	680	25 x 40	2.18	1.36	210	350	205	340	42681E3	22681E3
	680	30 x 30	2.04	1.36	210	350	205	340	52681E3	72681E3
	680	35 x 25	2.06	1.36	210	350	205	340	62681E3	82681E3
	820	25 x 45	2.46	1.64	170	290	145	240	62821E3	82821E3
	820	30 x 35	2.35	1.64	170	290	145	240	32821E3	12821E3
	820	35 x 30	2.29	1.64	170	290	145	240	52821E3	72821E3
	1000	30 x 40	2.66	2.00	140	235	135	225	52102E3	72102E3
	1000	35 x 30	2.33	2.00	140	235	135	225	62102E3	82102E3
	1200	30 x 45	2.98	2.40	120	200	110	190	32122E3	12122E3
	1200	35 x 35	2.69	2.40	120	200	110	190	62122E3	82122E3
	1500	30 x 50	3.31	3.00	110	180	95	155	42152E3	22152E3
	1500	35 x 40	3.04	3.00	110	180	95	155	52152E3	72152E3
1800	35 x 45	3.36	3.60	100	160	80	130	42182E3	22182E3	
2200	35 x 50	3.68	4.40	90	150	65	105	52222E3	72222E3	
250	220	22 x 30	1.23	0.55	600	1080	420	700	53221E3	73221E3
	270	22 x 30	1.32	0.67	490	880	335	560	43271E3	23271E3
	270	25 x 25	1.23	0.67	490	880	335	560	53271E3	73271E3
	330	22 x 35	1.53	0.82	400	720	255	430	33331E3	13331E3
	330	25 x 30	1.56	0.82	400	720	255	430	53331E3	73331E3



ELECTRICAL DATA AND ORDERING INFORMATION										
U _R (V)	C _R 100 Hz (μF)	NOMINAL CASE SIZE Ø D x L (mm)	I _R 120 Hz 85 °C (A)	I _{L5} 5 min (mA)	TYP. ESR 100 Hz ⁽¹⁾ (MΩ)	MAX. ESR 100 Hz ⁽¹⁾ (MΩ)	TYP. Z 10 kHz (MΩ)	MAX. Z 10 kHz (MΩ)	ORDERING CODE MAL2157.....	
									2-TERM.	3-TERM.
250	390	22 x 40	1.74	0.97	330	610	250	425	43391E3	23391E3
	390	30 x 25	1.58	0.97	330	610	250	425	53391E3	73391E3
	470	25 x 35	1.87	1.17	280	505	190	320	33471E3	13471E3
	470	30 x 30	1.89	1.17	280	505	190	320	53471E3	73471E3
	560	25 x 40	2.12	1.40	240	425	185	310	43561E3	23561E3
	560	30 x 30	1.97	1.40	240	425	185	310	53561E3	73561E3
	560	35 x 25	1.80	1.40	240	425	185	310	63561E3	83561E3
	680	25 x 45	2.29	1.70	200	350	155	260	63681E3	83681E3
	680	30 x 35	2.28	1.70	200	350	155	260	33681E3	13681E3
	680	35 x 30	2.20	1.70	200	350	155	260	53681E3	73681E3
	820	30 x 40	2.57	2.05	160	290	125	210	53821E3	73821E3
	820	35 x 35	2.54	2.05	160	290	125	210	63821E3	83821E3
	1000	30 x 45	2.88	2.50	140	235	105	180	33102E3	13102E3
	1000	35 x 40	2.86	2.50	140	235	105	180	53102E3	73102E3
	1200	35 x 45	3.17	3.00	120	200	95	160	43122E3	23122E3
	1500	35 x 50	3.49	3.75	90	160	85	140	53152E3	73152E3
400	68	22 x 25	0.71	0.27	1400	2800	1170	1950	56689E3	76689E3
	82	22 x 25	0.77	0.33	1250	2500	970	1620	56829E3	76829E3
	100	22 x 30	0.94	0.40	1125	2250	750	1220	56101E3	76101E3
	120	22 x 30	0.97	0.48	990	1980	700	1140	56121E3	76121E3
	150	22 x 35	1.13	0.60	750	1500	540	900	36151E3	16151E3
	150	25 x 30	1.16	0.60	750	1500	540	900	56151E3	76151E3
	180	22 x 40	1.29	0.72	630	1260	435	725	46181E3	26181E3
	180	25 x 35	1.35	0.72	630	1260	435	725	36181E3	16181E3
	220	25 x 40	1.54	0.88	520	1040	355	590	46221E3	26221E3
	220	30 x 30	1.50	0.88	520	1040	355	590	56221E3	76221E3
	220	35 x 25	1.42	0.88	520	1040	355	590	66221E3	86221E3
	270	25 x 45	1.72	1.08	430	860	335	560	66271E3	86271E3
	270	30 x 35	1.74	1.08	430	860	335	560	36271E3	16271E3
	270	35 x 30	1.71	1.08	430	860	335	560	56271E3	76271E3
	330	30 x 40	1.97	1.32	350	700	315	525	56331E3	76331E3
	330	35 x 30	1.76	1.32	350	700	315	525	66331E3	86331E3
	390	30 x 45	2.19	1.56	300	610	250	420	56391E3	76391E3
	390	35 x 35	2.04	1.56	300	610	250	420	36391E3	16391E3
	470	30 x 50	2.40	1.88	250	505	210	350	46471E3	26471E3
	470	35 x 40	2.30	1.88	250	505	210	350	56471E3	76471E3
560	35 x 45	2.55	2.24	210	425	180	305	46561E3	26561E3	
680	35 x 50	2.79	2.72	190	380	160	265	56681E3	76681E3	
820	35 x 60	3.33	3.28	155	315	115	215	56821E3	76821E3	

ELECTRICAL DATA AND ORDERING INFORMATION

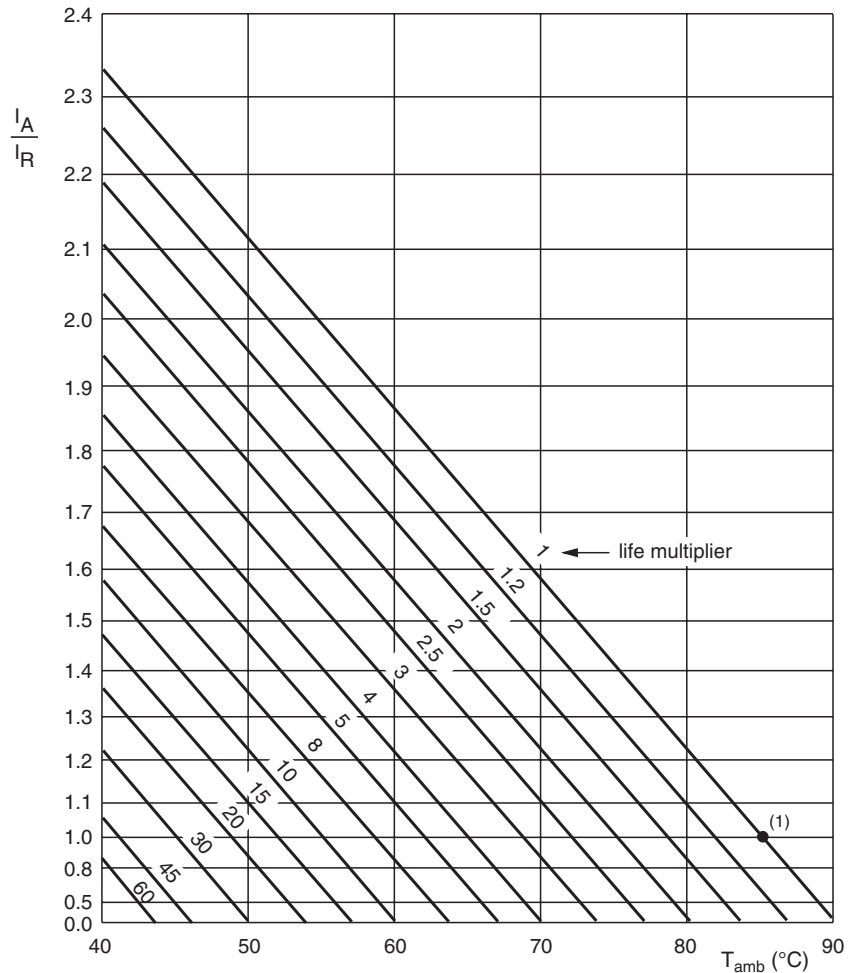
U _R (V)	C _R 100 Hz (μF)	NOMINAL CASE SIZE Ø D x L (mm)	I _R 120 Hz 85 °C (A)	I _{L5} 5 min (mA)	TYP. ESR 100 Hz ⁽¹⁾ (MΩ)	MAX. ESR 100 Hz ⁽¹⁾ (MΩ)	TYP. Z 10 kHz (MΩ)	MAX. Z 10 kHz (MΩ)	ORDERING CODE MAL2157.....	
									2-TERM.	3-TERM.
450	56	22 x 25	0.68	0.25	1650	3300	1120	1880	57569E3	77569E3
	68	22 x 30	0.80	0.30	1400	2800	920	1530	57689E3	77689E3
	82	22 x 30	0.87	0.36	1200	2400	780	1290	47829E3	27829E3
	82	25 x 25	0.85	0.36	1200	2400	780	1290	57829E3	77829E3
	100	22 x 35	1.00	0.45	1000	2000	630	1050	37101E3	17101E3
	100	25 x 30	1.02	0.45	1000	2000	630	1050	57101E3	77101E3
	120	22 x 40	1.15	0.54	800	1600	530	885	47121E3	27121E3
	120	25 x 30	1.09	0.54	800	1600	530	885	57121E3	77121E3
	120	30 x 25	1.10	0.54	800	1600	530	885	67121E3	87121E3
	150	25 x 40	1.35	0.67	650	1300	420	705	47151E3	27151E3
	150	25 x 35	1.27	0.67	650	1300	420	705	67151E3	87151E3
	150	30 x 30	1.32	0.67	650	1300	420	705	57151E3	77151E3
	180	25 x 40	1.45	0.81	570	1150	360	605	47181E3	27181E3
	180	30 x 35	1.49	0.81	570	1150	360	605	57181E3	77181E3
	180	35 x 25	1.35	0.81	570	1150	360	605	67181E3	87181E3
	220	25 x 50	1.73	0.99	450	900	315	525	47221E3	27221E3
	220	30 x 40	1.72	0.99	450	900	315	525	57221E3	77221E3
	220	35 x 30	1.61	0.99	450	900	315	525	67221E3	87221E3
	270	30 x 45	1.95	1.21	380	770	270	450	37271E3	17271E3
	270	35 x 35	1.86	1.21	380	770	270	450	67271E3	87271E3
330	30 x 50	2.19	1.48	300	600	230	390	47331E3	27331E3	
330	35 x 40	2.10	1.48	300	600	230	390	57331E3	77331E3	
390	35 x 45	2.34	1.75	250	500	190	340	47391E3	27391E3	
470	35 x 50	2.60	2.11	210	420	170	290	57471E3	77471E3	
680	35 x 60	3.15	3.06	150	300	110	200	57681E3	77681E3	

Note⁽¹⁾ ESR at 120 Hz is approximately 0.95 x ESR 100 Hz**ADDITIONAL ELECTRICAL DATA**

PARAMETER	CONDITIONS	VALUE
Voltage		
Surge voltage	≥ 400 V versions	U _s = 1.1 x U _R
	≤ 250 V versions	U _s = 1.15 x U _R
Reverse voltage		≤ 1 V
Current		
Leakage current	After 5 minutes at U _R	I _{L5} ≤ 0.01 C _R x U _R
Inductance		
Equivalent series inductance (ESL)	All case sizes	typ. 19 nH
		max. 25 nH

RIPPLE CURRENT AND USEFUL LIFE

MGA453



I_A = actual ripple current at 120 Hz
 I_R = rated ripple current at 120 Hz and 85 °C
 (1) Useful life at 85 °C and I_R applied: 5000 hours

Fig.6 Multiplier of useful life as a function of ambient temperature and ripple current load

Table 3

MULTIPLIER OF RIPPLE CURRENT (I_R) AS A FUNCTION OF FREQUENCY	
FREQUENCY (Hz)	I_R MULTIPLIER
50	0.90
100	0.95
120	1.00
200	1.15
1000	1.30
≥ 10 000	1.40

Table 4

TEST PROCEDURES AND REQUIREMENTS			
TEST		PROCEDURE (quick reference)	REQUIREMENTS
NAME OF TEST	REFERENCE		
Endurance	IEC 60384-4/ EN130300 subclause 4.13	$T_{amb} = 85\text{ }^{\circ}\text{C}$; U_R applied; 3000 hours	$\Delta C/C: \pm 10\%$ $ESR \leq 2 \times \text{spec. limit}$ $I_{L5} \leq \text{spec. limit}$
Load life		$T_{amb} = 85\text{ }^{\circ}\text{C}$; U_R and I_R applied; 3000 hours	$\Delta C/C: \pm 20\%$ $ESR \leq 2 \times \text{spec. limit}$ $I_{L5} \leq \text{spec. limit}$
Useful life	CECC 30301 subclause 1.8.1	$T_{amb} = 85\text{ }^{\circ}\text{C}$; U_R and I_R applied; 5000 hours	$\Delta C/C: \pm 30\%$ $ESR \leq 3 \times \text{spec. limit}$ $I_{L5} \leq \text{spec. limit}$ no short or open circuit, no visible damage total failure percentage: $\leq 3\%$
Shelf life (storage at high temperature)	IEC 60384-4/ EN130300 subclause 4.17	$T_{amb} = 85\text{ }^{\circ}\text{C}$; no voltage applied; 1000 hours After test: U_R to be applied for 30 minutes, 24 hours to 48 hours before measurement	$\Delta C/C: \pm 15\%$ $ESR \leq 1.5 \times \text{spec. limit}$ $I_{L5} \leq 1 \times \text{spec. limit}$

Aluminum Capacitors Power General Purpose Snap-In

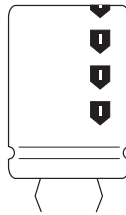
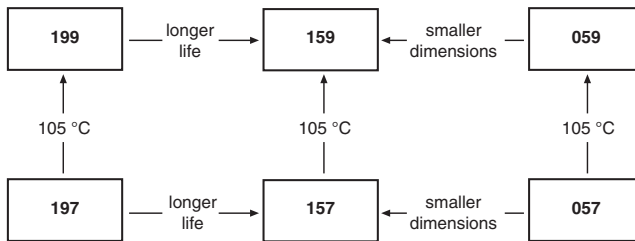


Fig.1 Component outline



QUICK REFERENCE DATA	
DESCRIPTION	VALUE
Nominal case size (Ø D x L in mm)	22 x 25 to 35 x 50
Rated capacitance range (E6/E12 series), C _R	56 µF to 2200 µF
Tolerance on C _R	± 20 %
Rated voltage range, U _R	160 V, 200 V, 250 V, 400 V, 450 V
Category temperature range	- 25 °C to + 85 °C
Useful life at 85 °C	3000 hours
Useful life at 40 °C and 1.4 x I _R applied	90 000 hours
Shelf life at 0 V, 85 °C	1000 hours
Based on sectional specification	IEC 60384-4/EN130300/W of JISC5141

FEATURES

- Polarized aluminum electrolytic capacitors, non-solid electrolyte
- Large types, very small dimensions, cylindrical aluminum case insulated with a blue sleeve
- Useful life: 3000 hours at 85 °C


**RoHS
COMPLIANT**
APPLICATIONS

- Consumer and industrial electronics
- Whitegood motor control
- Electronic drives
- Smmps/ups

MARKING

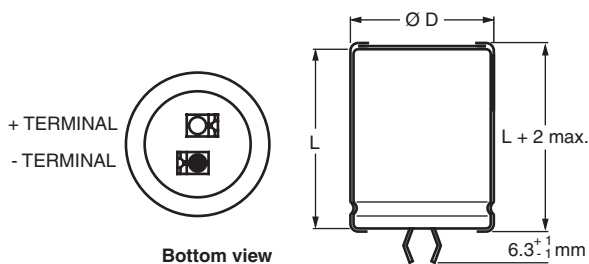
The capacitors are marked (where possible) with the following information:

- Rated capacitance (in µF)
- Tolerance on rated capacitance, code letter in accordance with IEC 60062 (M for ± 20 %)
- Rated voltage (in V)
- Date code
- Name of manufacturer
- ‘-’ sign to identify the negative terminal, visible from the top and side of the capacitor
- Code number (last 8 digits)
- Maximum operating temperature

SELECTION CHART FOR C _R , U _R AND RELEVANT NOMINAL CASE SIZES (Ø D x L in mm)					
C _R (µF)	U _R (V)				
	160	200	250	400	450
56	-	-	-	-	22 x 25
68	-	-	-	22 x 25	22 x 25
82	-	-	-	22 x 25	22 x 30
	-	-	-	-	25 x 25
100	-	-	-	22 x 30	22 x 35
	-	-	-	25 x 25	25 x 30
120	-	-	-	-	22 x 40
	-	-	-	22 x 35	25 x 30
	-	-	-	25 x 35	30 x 25
150	22 x 25	22 x 25	22 x 25	22 x 35	-
	-	-	-	25 x 30	25 x 35
	-	-	-	30 x 25	30 x 30
180	22 x 25	22 x 25	22 x 25	22 x 40	-
	-	-	-	25 x 35	25 x 40
	-	-	-	30 x 25	30 x 30
	-	-	-	-	35 x 30
220	22 x 25	22 x 25	22 x 30	-	-
	-	-	25 x 25	25 x 40	30 x 35
	-	-	-	30 x 30	35 x 30
	-	-	-	-	-

SELECTION CHART FOR C_R, U_R AND RELEVANT NOMINAL CASE SIZES (∅ D x L in mm)					
C _R (μF)	U _R (V)				
	160	200	250	400	450
270	22 x 25	22 x 25	22 x 30	-	30 x 40
	-	-	25 x 25	30 x 35	35 x 35
	-	-	-	35 x 30	-
	-	-	-	-	-
330	22 x 25	22 x 30	22 x 35	25 x 50	30 x 50
	-	25 x 25	25 x 30	30 x 40	35 x 40
	-	-	30 x 25	35 x 30	-
390	22 x 30	22 x 30	22 x 40	30 x 45	30 x 50
	-	25 x 25	25 x 35	35 x 35	35 x 50
	-	-	30 x 25	-	-
470	22 x 30	22 x 35	-	30 x 50	35 x 50
	25 x 25	25 x 30	25 x 40	35 x 40	-
	-	30 x 25	30 x 30	-	-
560	25 x 25	22 x 40	25 x 40	35 x 45	-
	30 x 25	25 x 35	-	-	-
	-	30 x 25	30 x 35	-	-
680	25 x 30	25 x 40	25 x 50	35 x 50	-
	30 x 25	30 x 30	30 x 40	-	-
	-	-	35 x 30	-	-
820	25 x 35	-	30 x 45	-	-
	-	30 x 35	35 x 35	-	-
	-	35 x 30	-	-	-
1000	25 x 40	30 x 40	30 x 50	-	-
	30 x 30	35 x 35	35 x 40	-	-
1200	30 x 35	30 x 45	35 x 50	-	-
	35 x 30	35 x 35	-	-	-
1500	35 x 35	35 x 50	35 x 50	-	-
1800	30 x 50	-	-	-	-
	35 x 40	-	-	-	-
2200	35 x 50	35 x 50	-	-	-

DIMENSIONS in millimeters AND AVAILABLE FORMS



The minus terminal can be marked with an imprinted sign

Fig.2 Two terminal snap-in

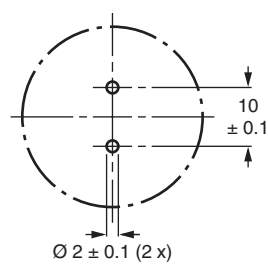


Fig.3 Mounting hole diagram

Table 1

DIMENSIONS in millimeters, MASS AND PACKAGING QUANTITIES					
NOMINAL CASE SIZE ∅ D x L	∅ D _{max.}	L _{max.}	MASS (g)	PACKAGING QUANTITIES	CARDBOARD BOX DIMENSIONS L x W x H
22 x 25	22.5	25.5	≈ 12	216	280 x 240 x 140
22 x 30	22.5	30.5	≈ 16	216	280 x 240 x 140
22 x 35	22.5	35.5	≈ 20	144	280 x 240 x 105
22 x 40	22.5	40.5	≈ 23	144	280 x 240 x 105
22 x 45	22.5	45.5	≈ 26	144	280 x 240 x 140
22 x 50	22.5	50.5	≈ 29	72	280 x 240 x 105
25 x 25	25.5	25.5	≈ 20	216	280 x 240 x 140
25 x 30	25.5	32.0	≈ 22	216	280 x 240 x 140
25 x 35	25.5	35.5	≈ 24	144	280 x 240 x 105



DIMENSIONS in millimeters, MASS AND PACKAGING QUANTITIES					
NOMINAL CASE SIZE Ø D x L	Ø D _{max.}	L _{max.}	MASS (g)	PACKAGING QUANTITIES	CARDBOARD BOX DIMENSIONS L x W x H
25 x 40	25.5	40.5	≈ 27	144	280 x 240 x 105
25 x 45	25.5	45.5	≈ 32	144	280 x 240 x 140
25 x 50	25.5	50.5	≈ 38	144	280 x 240 x 140
30 x 25	30.5	27.5	≈ 25	168	280 x 240 x 140
30 x 30	30.5	32.5	≈ 30	168	280 x 240 x 140
30 x 35	30.5	37.5	≈ 35	112	280 x 240 x 105
30 x 40	30.5	41.5	≈ 40	112	280 x 240 x 105
30 x 45	30.5	46.5	≈ 45	112	280 x 240 x 140
30 x 50	30.5	51.5	≈ 50	112	280 x 240 x 140
35 x 25	35.5	25.5	≈ 33	126	280 x 240 x 140
35 x 30	35.5	32.5	≈ 40	126	280 x 240 x 140
35 x 35	35.5	35.5	≈ 48	84	280 x 240 x 105
35 x 40	35.5	41.5	≈ 55	84	280 x 240 x 105
35 x 45	35.5	46.5	≈ 63	84	280 x 240 x 140
35 x 50	35.5	51.5	≈ 72	84	280 x 240 x 140

ELECTRICAL DATA	
SYMBOL	DESCRIPTION
C _R	rated capacitance at 120 Hz
I _R	rated RMS ripple current at 120 Hz, 85 °C
I _{L5}	max. leakage current after 5 minutes at U _R
ESR	max. equivalent series resistance at 120 Hz ⁽¹⁾

Notes

- ⁽¹⁾ ESR at 100 Hz is approximately 1.05 x ESR 120 Hz
- Unless otherwise specified, all electrical values in table 2 apply at T_{amb} = 20 °C, P = 86 kPa to 106 kPa, RH = 45 % to 75 %

Table 2

ELECTRICAL DATA AND ORDERING INFORMATION						
U _R (V)	C _R 120 Hz (µF)	NOMINAL CASE SIZE Ø D x L (mm)	I _R 120 Hz 85 °C (A)	I _{L5} 5 min (mA)	MAX. ESR 120 ⁽¹⁾ (Ω)	ORDERING CODE MAL2197.....
160	150	22 x 25	0.92	0.48	1.11	11151E3
	180	22 x 25	0.99	0.58	0.92	11181E3
	220	22 x 25	1.08	0.70	0.75	11221E3
	270	22 x 25	1.16	0.86	0.61	11271E3
	330	22 x 25	1.24	1.06	0.50	11331E3
	390	22 x 30	1.45	1.25	0.43	11391E3
	470	22 x 30	1.53	1.50	0.35	11471E3
	470	25 x 25	1.45	1.50	0.35	21471E3
	560	30 x 25	1.67	1.50	0.30	31561E3
	680	25 x 30	1.82	1.50	0.24	21681E3
	680	30 x 25	1.70	1.50	0.24	31681E3
	820	25 x 35	2.04	1.50	0.20	21821E3
	1000	30 x 30	2.07	1.50	0.17	31102E3
	1000	35 x 30	2.24	1.50	0.17	41102E3
	1200	30 x 35	2.28	1.50	0.17	21122E3
	1200	35 x 30	2.22	1.50	0.17	31122E3
	1500	35 x 35	2.42	1.50	0.15	21152E3
	1500	35 x 40	2.72	1.50	0.13	31152E3
1800	30 x 50	3.08	1.50	0.11	11182E3	
1800	35 x 40	2.66	1.50	0.13	21182E3	
2200	35 x 50	3.25	1.50	0.10	41222E3	

ORDERING EXAMPLE

Electrolytic capacitor 197 series
 1000 µF/200 V; ± 20 %
 Nominal case size: Ø 30 x 40 mm
 2-terminal snap-in:
 Ordering code: MAL219722102E3
 Former 12NC: 222219722102

ELECTRICAL DATA AND ORDERING INFORMATION

U_R (V)	C_R 120 Hz (μ F)	NOMINAL CASE SIZE \varnothing D x L (mm)	I_R 120 Hz 85 °C (A)	I_{L5} 5 min (mA)	MAX. ESR 120 ⁽¹⁾ (Ω)	ORDERING CODE MAL2197.....
200	150	22 x 25	1.06	0.60	1.11	12151E3
	180	22 x 25	1.15	0.72	0.92	12181E3
	220	22 x 25	1.24	0.88	0.75	12221E3
	270	22 x 25	1.34	1.08	0.61	12271E3
	330	22 x 30	1.58	1.32	0.50	12331E3
	330	25 x 25	1.53	1.32	0.50	22331E3
	390	25 x 25	1.59	1.50	0.45	22391E3
	470	22 x 35	1.92	1.50	0.35	12471E3
	470	25 x 30	1.92	1.50	0.35	22471E3
	470	30 x 25	1.86	1.50	0.38	32471E3
	560	25 x 35	2.16	1.50	0.30	22561E3
	560	30 x 25	1.90	1.50	0.34	32561E3
	680	25 x 40	2.44	1.50	0.24	22681E3
	680	30 x 30	2.28	1.50	0.27	32681E3
	820	30 x 35	2.55	1.50	0.24	32821E3
	820	35 x 30	2.52	1.50	0.26	42821E3
	1000	30 x 40	2.84	1.50	0.20	22102E3
	1000	35 x 35	2.79	1.50	0.22	32102E3
	1200	30 x 45	3.16	1.50	0.17	12122E3
	1200	35 x 35	2.77	1.50	0.21	22122E3
1500	35 x 50	3.72	1.50	0.15	22152E3	
2200	35 x 50	3.70	1.50	0.11	12222E3	
250	150	22 x 25	1.07	0.75	1.11	13151E3
	180	22 x 25	1.16	0.90	0.92	13181E3
	220	22 x 30	1.36	1.10	0.75	13221E3
	220	25 x 25	1.34	1.10	0.75	23221E3
	270	22 x 30	1.47	1.35	0.61	13271E3
	270	25 x 25	1.42	1.35	0.61	23271E3
	330	22 x 35	1.70	1.50	0.50	13331E3
	330	25 x 30	1.71	1.50	0.50	23331E3
	330	30 x 25	1.68	1.50	0.50	33331E3
	390	22 x 40	1.92	1.50	0.43	13391E3
	390	25 x 35	1.92	1.50	0.43	23391E3
	390	30 x 25	1.74	1.50	0.43	33391E3
	470	25 x 40	2.17	1.50	0.35	23471E3
	470	30 x 30	2.07	1.50	0.35	33471E3
	560	25 x 40	2.28	1.50	0.27	53561E3
	560	30 x 35	2.32	1.50	0.30	33561E3
	680	25 x 50	2.73	1.50	0.24	13681E3
	680	30 x 40	2.60	1.50	0.24	23681E3
	680	35 x 30	2.36	1.50	0.27	33681E3
	820	30 x 45	2.90	1.50	0.20	13821E3
	820	35 x 35	2.61	1.50	0.24	23821E3
	1000	30 x 50	3.21	1.50	0.17	13102E3
	1000	35 x 40	2.89	1.50	0.21	23102E3
	1200	35 x 50	3.49	1.50	0.19	13122E3
	1500	35 x 50	3.56	1.50	0.19	13152E3



Aluminum Capacitors
Power General Purpose Snap-In

Vishay BCcomponents

ELECTRICAL DATA AND ORDERING INFORMATION						
U_R (V)	C_R 120 Hz (μ F)	NOMINAL CASE SIZE \varnothing D x L (mm)	I_R 120 Hz 85 °C (A)	I_{L5} 5 min (mA)	MAX. ESR 120 ⁽¹⁾ (Ω)	ORDERING CODE MAL2197.....
400	68	22 x 25	0.57	0.55	3.66	16689E3
	82	22 x 25	0.62	0.66	3.03	16829E3
	100	22 x 30	0.73	0.80	2.49	16101E3
	100	25 x 25	0.73	0.80	2.49	26101E3
	120	22 x 35	0.84	0.96	2.07	16121E3
	120	25 x 35	0.89	0.96	2.07	26121E3
	150	22 x 35	0.93	1.20	1.66	16151E3
	150	25 x 30	0.94	1.20	1.66	26151E3
	150	30 x 25	0.96	1.20	1.66	36151E3
	180	25 x 35	1.07	1.44	1.38	26181E3
	180	30 x 25	1.03	1.44	1.38	36181E3
	220	25 x 40	1.23	1.50	1.13	26221E3
	220	30 x 30	1.21	1.50	1.13	36221E3
	270	30 x 35	1.38	1.50	0.92	26271E3
	270	35 x 30	1.41	1.50	0.92	36271E3
	330	30 x 40	1.57	1.50	0.75	26331E3
	330	35 x 30	1.49	1.50	0.78	36331E3
	390	30 x 45	1.75	1.50	0.64	16391E3
	390	35 x 35	1.67	1.50	0.66	26391E3
	470	30 x 50	1.96	1.50	0.53	16471E3
470	35 x 40	1.87	1.50	0.56	26471E3	
560	35 x 45	2.08	1.50	0.47	16561E3	
680	35 x 50	2.31	1.50	0.39	16681E3	
450	56	22 x 25	0.53	0.28	4.44	17569E3
	68	22 x 25	0.58	0.34	3.66	17689E3
	82	22 x 30	0.68	0.41	3.03	17829E3
	82	25 x 25	0.68	0.41	3.03	27829E3
	100	22 x 35	0.78	0.50	2.49	17101E3
	100	25 x 30	0.80	0.50	2.49	27101E3
	120	22 x 40	0.89	0.60	2.07	17121E3
	120	25 x 30	0.86	0.60	2.07	27121E3
	120	30 x 25	0.89	0.60	2.07	37121E3
	150	25 x 35	1.00	0.75	1.66	27151E3
	150	30 x 30	1.05	0.75	1.66	37151E3
	180	25 x 40	1.14	0.90	1.38	27181E3
	180	30 x 30	1.13	0.90	1.38	37181E3
	180	35 x 30	1.22	0.90	1.38	47181E3
	220	30 x 35	1.29	1.10	1.13	27221E3
	220	35 x 30	1.32	1.10	1.13	37221E3
	270	30 x 40	1.47	1.35	0.92	17271E3
	330	30 x 50	1.74	1.50	0.75	17331E3
	330	35 x 40	1.69	1.50	0.75	27331E3
	390	35 x 50	1.97	1.50	0.64	27391E3
470	35 x 50	2.10	1.50	0.53	17471E3	

Note

⁽¹⁾ ESR at 100 Hz is approximately 1.05 x ESR 120 Hz



ADDITIONAL ELECTRICAL DATA		
PARAMETER	CONDITIONS	VALUE
Voltage		
Surge voltage	≥ 400 V versions	$U_s = 1.1 \times U_R$
	≤ 250 V versions	$U_s = 1.15 \times U_R$
Reverse voltage	≤ 1 V	-
Current		
Leakage current	After 5 minutes at U_R	$I_{L5} \leq 0.02 C_R \times U_R$ or 1.5 mA, whichever is smaller

Table 3

LOW TEMPERATURE CHARACTERISTIC (at 120 Hz)						
DESCRIPTION	Z(- 25 °C)/Z(+ 20 °C)	U_R (V) ⁽¹⁾				
		160	200	250	400	450
Impedance ratio	Z(- 25 °C)/Z(+ 20 °C)	4	4	4	4	4

Note

⁽¹⁾ Impedance ratio shall not exceed the given values

Table 4

DISSIPATION FACTOR (tan δ at 120 Hz, 20 °C)						
DESCRIPTION		U_R (V)				
		160	200	250	400	450
tan δ (max.)		0.10 ⁽¹⁾	0.10 ⁽¹⁾	0.10 ⁽¹⁾	0.15	0.15

Note

⁽¹⁾ 0.15 for Ø D = 35 mm

RIPPLE CURRENT AND USEFUL LIFE

I_A = actual ripple current at 120 Hz
 I_R = rated ripple current at 120 Hz and 85 °C
⁽¹⁾ Useful life at 85 °C and I_R applied: 3000 hours

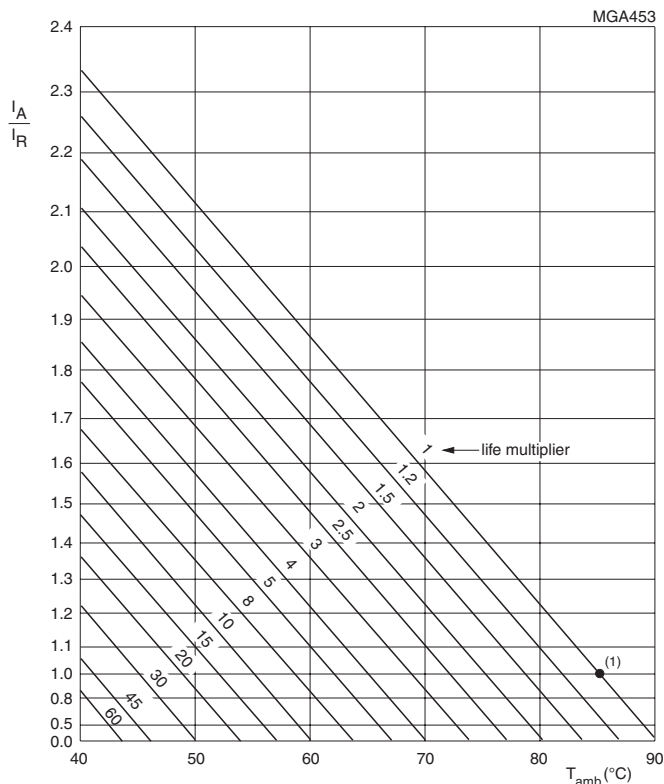


Fig.4 Multiplier of useful life as a function of ambient temperature and ripple current load



Table 5

MULTIPLIER OF RIPPLE CURRENT (I_R) AS A FUNCTION OF FREQUENCY		
FREQUENCY (Hz)	I_R MULTIPLIER	
	160 V to 250 V	400 V and 450 V
60	0.81	0.90
100	0.97	0.95
120	1.00	1.00
500	1.32	1.20
1000	1.45	1.30
$\geq 10\ 000$	1.50	1.40

Table 6

TEST PROCEDURES AND REQUIREMENTS			
TEST		PROCEDURE (quick reference)	REQUIREMENTS
NAME OF TEST	REFERENCE		
Useful life	CECC 30301 subclause 1.8.1	$T_{amb} = 85\ ^\circ\text{C}$; U_R and I_R applied; 3000 hours	$\Delta C/C: \pm 30\ \%$ ESR $\leq 3 \times$ spec. limit $I_{L5} \leq$ spec. limit no short or open circuit, no visible damage total failure percentage: $\leq 3\ \%$
Shelf life (storage at high temperature)	IEC 60384-4/ EN130300 subclause 4.17	$T_{amb} = 85\ ^\circ\text{C}$; no voltage applied; 1000 hours After test: U_R to be applied for 30 minutes, 24 hours to 48 hours before measurement	$\Delta C/C: \pm 20\ \%$ ESR $\leq 2 \times$ spec. limit $I_{L5} \leq 1 \times$ spec. limit

Aluminum Capacitors Power Standard Miniature Snap-In

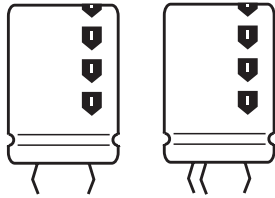
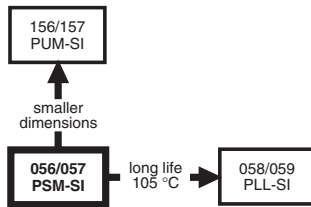


Fig.1 Component outlines



FEATURES

- Polarized aluminum electrolytic capacitors, non-solid electrolyte
- Large types, minimized dimensions, cylindrical aluminum case, insulated with a blue sleeve
- Pressure relief on the top of the aluminum case
- Charge and discharge proof
- Long useful life: 12 000 hours at 85 °C
- High ripple current capability
- Keyed polarity version available



APPLICATIONS

- General purpose, industrial and audio/video systems
- Smoothing and filtering
- Standard and switched mode power supplies
- Energy storage in pulse systems

MARKING

The capacitors are marked (where possible) with the following information:

- Rated capacitance (in μF)
- Tolerance code on rated capacitance, code letter in accordance with IEC 60062 (M for $\pm 20\%$)
- Rated voltage (in V)
- Date code (YYMM)
- Name of manufacturer
- Code for factory of origin
- ‘-’ sign to identify the negative terminal, visible from the top and side of the capacitor
- Code number
- Climatic category in accordance with IEC 60068

QUICK REFERENCE DATA		
DESCRIPTION	VALUE	
	056	057
Nominal case size (\varnothing D x L in mm)	22 x 25 to 35 x 50	
Rated capacitance range (E6 series), C_R	470 μF to 68 000 μF	47 μF to 1500 μF
Tolerance on C_R	$\pm 20\%$	
Rated voltage range, U_R ⁽¹⁾	10 V to 100 V	200 V to 450 V
Category temperature range	- 25 °C to + 85 °C	- 25 °C to + 85 °C
Endurance test at 85 °C	5000 hours (450 V: 2000 hours)	
Useful life at 85 °C	12 000 hours (450 V: 5000 hours)	
Useful life at 40 °C and 1.4 x I_R applied	210 000 hours (450 V: 90 000 hours)	
Shelf life at 0 V, 85 °C	500 hours	
Based on sectional specification	IEC 60384-4/EN130300	
Climatic category IEC 60068	40/085/056	25/085/56

Note

⁽¹⁾ A 420 V range is available on request

SELECTION CHART FOR C_R , U_R AND RELEVANT NOMINAL CASE SIZES FOR 056 SERIES (\varnothing D x L in mm)							
C_R (μF)	U_R (V)						
	10	16	25	40	50	63	100
470	-	-	-	-	-	-	22 x 25
680	-	-	-	-	-	-	22 x 30
1000	-	-	-	-	-	22 x 25	25 x 30
	-	-	-	-	-	-	22 x 40
1500	-	-	-	-	22 x 25	22 x 30	30 x 30
	-	-	-	-	-	-	25 x 40
2200	-	-	-	22 x 25	22 x 30	25 x 30	30 x 40
	-	-	-	-	-	22 x 40	25 x 50
3300	-	-	22 x 25	22 x 30	25 x 30	30 x 30	35 x 40
	-	-	-	-	22 x 40	25 x 40	30 x 50

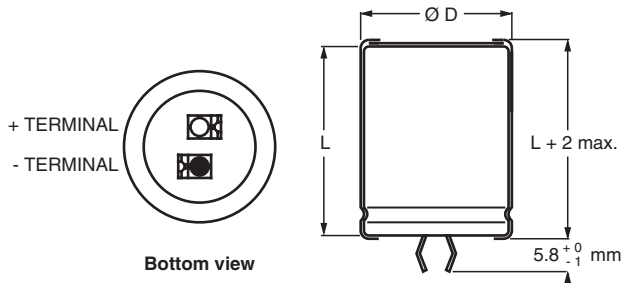


SELECTION CHART FOR C_R, U_R AND RELEVANT NOMINAL CASE SIZES FOR 056 SERIES (∅ D x L in mm)							
C _R (μF)	U _R (V)						
	10	16	25	40	50	63	100
4700	-	22 x 25	22 x 30	25 x 30	30 x 30	30 x 40	35 x 50
	-	-	-	22 x 40	25 x 40	25 x 50	-
6800	22 x 25	22 x 30	25 x 30	30 x 30	30 x 40	35 x 40	-
	-	-	22 x 40	25 x 40	25 x 50	30 x 50	-
10 000	22 x 30	25 x 30	30 x 30	30 x 40	35 x 40	35 x 50	-
	-	22 x 40	25 x 40	25 x 50	30 x 50	-	-
15 000	25 x 30	30 x 30	30 x 40	35 x 40	35 x 50	-	-
	22 x 40	25 x 40	25 x 50	30 x 50	-	-	-
22 000	30 x 30	30 x 40	35 x 40	35 x 50	-	-	-
	25 x 40	25 x 50	30 x 50	-	-	-	-
33 000	30 x 40	35 x 40	35 x 50	-	-	-	-
	25 x 50	30 x 50	-	-	-	-	-
47 000	35 x 40	35 x 50	-	-	-	-	-
	30 x 50	-	-	-	-	-	-
68 000	35 x 50	-	-	-	-	-	-

SELECTION CHART FOR C_R, U_R AND RELEVANT NOMINAL CASE SIZES FOR 057 SERIES (∅ D x L in mm)					
C _R (μF)	U _R (V)				
	200	250	385	400	450
47	-	-	22 x 25	22 x 25	22 x 30
68	-	-	22 x 30	22 x 30	22 x 30
100	-	22 x 25	25 x 30	25 x 30	30 x 30
	-	-	22 x 40	22 x 35	25 x 35
	-	-	22 x 35	-	-
150	22 x 25	22 x 30	30 x 30	30 x 30	25 x 50
	-	-	25 x 40	-	30 x 35
	-	-	-	25 x 40	-
220	22 x 30	25 x 30	30 x 45	30 x 35	35 x 40
	-	22 x 40	30 x 40	25 x 40	30 x 45
	-	-	30 x 35	-	-
	-	-	25 x 50	-	-
330	25 x 30	30 x 30	35 x 35	35 x 40	35 x 50
	22 x 40	25 x 40	-	35 x 50	35 x 45
470	30 x 30	30 x 40	35 x 50	35 x 50	-
	25 x 40	25 x 50	35 x 45	-	-
680	30 x 40	35 x 40	-	-	-
	25 x 50	30 x 50	-	-	-
1000	35 x 40	35 x 50	-	-	-
	30 x 50	-	-	-	-
1500	35 x 50	-	-	-	-

DIMENSIONS in millimeters **AND AVAILABLE FORMS**

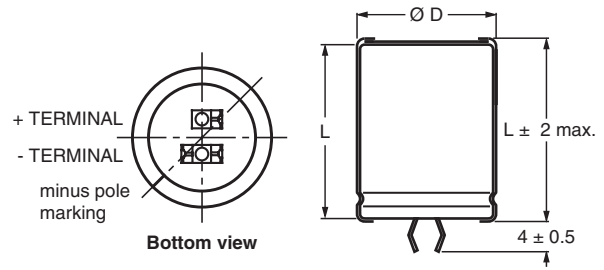
TWO TERMINALS SNAP-IN



The minus terminal can be marked with a black dot or with an imprinted '-' sign.

Fig.2 Two terminal snap-in

THREE TERMINAL SNAP-IN



The negative terminal has **TWO** pins which are **BOTH** electrically connected.

Fig.4 Three terminal snap-in

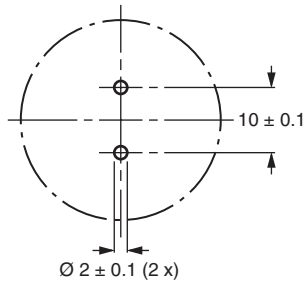
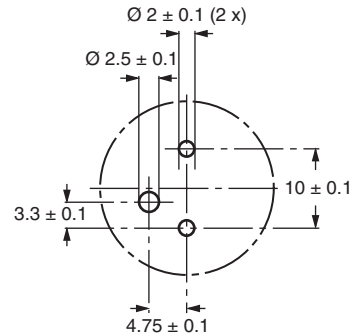


Fig.3 Mounting hole diagram



The 10 mm spacing of the 2 pin snap-in is used as the base layout and a third hole is added.

The third hole is closer to the negative primary hole so that polarization is always maintained, together with added mechanical stability.

Fig.5 Mounting hole diagram

Table 1

DIMENSIONS in millimeters, MASS AND PACKAGING QUANTITIES					
NOMINAL CASE SIZE Ø D x L	Ø D _{max.}	L _{max.}	MASS (g)	PACKAGING QUANTITIES (units per box)	CARDBOARD BOX DIMENSIONS L x W x H (mm)
22 x 25	23	27	≈ 12	100	260 x 250 x 39
22 x 30	23	32	≈ 16	100	260 x 250 x 44
22 x 35	23	37	≈ 20	100	260 x 250 x 49
22 x 40	23	42	≈ 23	100	260 x 250 x 54
25 x 30	26	32	≈ 22	100	290 x 280 x 44
25 x 35	26	37	≈ 24	100	290 x 280 x 49
25 x 40	26	42	≈ 27	100	290 x 280 x 54
25 x 50	26	52	≈ 38	100	290 x 280 x 64
30 x 30	31	32	≈ 30	100	340 x 330 x 44
30 x 35	31	37	≈ 35	100	340 x 330 x 49
30 x 40	31	42	≈ 40	100	340 x 330 x 54
30 x 45	31	47	≈ 45	100	340 x 330 x 59
30 x 50	31	52	≈ 50	100	340 x 330 x 64
35 x 35	36	37	≈ 48	50	390 x 198 x 49
35 x 40	36	42	≈ 55	50	390 x 198 x 54
35 x 45	36	47	≈ 63	50	390 x 198 x 59
35 x 50	36	52	≈ 72	50	390 x 198 x 64



Aluminum Capacitors
Power Standard Miniature Snap-In

Vishay BCcomponents

ELECTRICAL DATA	
SYMBOL	DESCRIPTION
C _R	rated capacitance at 100 Hz
I _R	rated RMS ripple current at 100 Hz or ≥ 10 kHz and 85 °C
I _{L1}	max. leakage current after 1 minute at U _R
I _{L5}	max. leakage current after 5 minutes at U _R
ESR	max. equivalent series resistance at 100 Hz
Z	max. impedance at 10 kHz

ORDERING EXAMPLE

Electrolytic capacitor 056 series
 10 000 µF/25 V; ± 20 %
 Nominal case size: Ø 25 x 40 mm
 2-terminal snap-in
 Ordering code: MAL205646103E3
 Former 12NC: 222205646103
 3-terminal snap-in
 Ordering code: MAL205626103E3
 Former 12NC: 222205626103

Note

- Unless otherwise specified, all electrical values in tables 2 and 3 apply at T_{amb} = 20 °C, P = 86 kPa to 106 kPa, RH = 45 % to 75 %

Table 2

ELECTRICAL DATA AND ORDERING INFORMATION FOR 056 SERIES										
U _R (V)	C _R 100 Hz (µF)	NOMINAL CASE SIZE Ø D x L (mm)	I _R 100 Hz 85 °C (A)	I _R ≥ 10 kHz 85 °C (A)	I _{L1} 1 min (µA)	I _{L5} 5 min (µA)	ESR 100 Hz (mΩ)	Z 10 kHz (mΩ)	ORDERING CODE MAL2056.....	
									2-TERM.	3-TERM.
10	6800	22 x 25	2.04	2.40	412	140	76	62	54682E3	74682E3
	10 000	22 x 30	2.56	3.02	608	205	56	45	54103E3	74103E3
	15 000	25 x 30	3.12	3.68	904	304	44	39	54153E3	74153E3
	15 000	22 x 40	3.39	4.00	904	304	41	34	44153E3	24153E3
	22 000	30 x 30	3.47	4.09	1324	444	44	37	54223E3	74223E3
	22 000	25 x 40	4.12	4.86	1324	444	34	28	44223E3	24223E3
	33 000	30 x 40	4.58	5.40	1984	664	32	28	54333E3	74333E3
	33 000	25 x 50	4.70	5.55	1984	664	30	27	44333E3	24333E3
	47 000	35 x 40	5.10	6.02	2824	944	31	26	54473E3	74473E3
	47 000	30 x 50	5.39	6.36	2824	944	28	24	44473E3	24473E3
68 000	35 x 50	5.88	6.94	4084	1364	28	23	54683E3	74683E3	
16	4700	22 x 25	2.01	2.37	455	154	79	62	55472E3	75472E3
	6800	22 x 30	2.54	3.00	657	222	57	45	55682E3	75682E3
	10 000	25 x 30	3.02	3.56	964	324	47	39	55103E3	75103E3
	10 000	22 x 40	3.28	3.87	964	324	44	34	45103E3	25103E3
	15 000	30 x 30	3.36	3.96	1444	484	47	37	55153E3	75153E3
	15 000	25 x 40	4.00	4.72	1444	484	34	28	45153E3	25153E3
	22 000	30 x 40	4.51	5.32	2116	708	33	28	55223E3	75223E3
	22 000	25 x 50	3.97	4.68	2116	708	42	41	45223E3	25223E3
	33 000	35 x 40	5.02	5.92	3172	1060	32	28	55333E3	75333E3
	33 000	30 x 50	4.75	5.61	3172	1060	36	34	45333E3	25333E3
47 000	35 x 50	5.34	6.30	4516	1508	34	32	55473E3	75473E3	
25	3300	22 x 25	1.88	2.22	499	169	89	61	56332E3	76332E3
	4700	22 x 30	2.37	2.80	709	239	65	45	56472E3	76472E3
	6800	25 x 30	2.81	3.32	1024	344	54	41	56682E3	76682E3
	6800	22 x 40	3.16	3.73	1024	344	47	38	46682E3	26682E3
	10 000	30 x 30	3.25	3.84	1504	504	50	38	56103E3	76103E3
	10 000	25 x 40	3.73	4.40	1504	504	39	30	46103E3	26103E3
	15 000	30 x 40	4.73	5.58	2254	754	30	28	56153E3	76153E3
	15 000	25 x 50	3.92	4.63	2254	754	43	39	46153E3	26153E3
	22 000	35 x 40	4.48	5.29	3304	1104	40	28	56223E3	76223E3
	22 000	30 x 50	4.96	5.85	3304	1104	36	23	46223E3	26223E3
	33 000	35 x 50	4.98	5.88	4954	1654	39	33	56333E3	76333E3

ELECTRICAL DATA AND ORDERING INFORMATION FOR 056 SERIES

U _R (V)	C _R 100 Hz (μF)	NOMINAL CASE SIZE Ø D x L (mm)	I _R 100 Hz 85 °C (A)	I _R ≥ 10 kHz 85 °C (A)	I _{L1} 1 min (μA)	I _{L5} 5 min (μA)	ESR 100 Hz (mΩ)	Z 10 kHz (mΩ)	ORDERING CODE MAL2056.....	
									2-TERM.	3-TERM.
40	2200	22 x 25	1.85	2.26	532	180	92	61	57222E3	77222E3
	3300	22 x 30	2.09	2.55	796	260	67	45	57332E3	77332E3
	4700	25 x 30	2.28	2.78	1132	380	82	70	57472E3	77472E3
	4700	22 x 40	3.10	3.78	1132	380	49	38	47472E3	27472E3
	6800	30 x 30	3.16	3.85	1636	548	53	38	57682E3	77682E3
	6800	25 x 40	3.06	3.73	1636	548	58	50	47682E3	27682E3
	10 000	30 x 40	4.20	5.12	2404	804	38	28	57103E3	77103E3
	10 000	25 x 50	3.88	4.73	2404	804	44	39	47103E3	27103E3
	15 000	35 x 40	4.05	4.94	3604	1204	49	41	57153E3	77153E3
	15 000	30 x 50	4.45	5.43	3604	1204	41	34	47153E3	27153E3
	22 000	35 x 50	4.86	5.93	5284	1764	40	33	57223E3	77223E3
50	1500	22 x 25	1.36	1.66	454	154	170	130	51152E3	71152E3
	2200	22 x 30	1.75	2.14	664	224	120	91	51222E3	71222E3
	3300	25 x 30	2.17	2.65	994	334	90	72	51332E3	71332E3
	3300	22 x 40	2.42	2.95	994	334	80	63	41332E3	21332E3
	4700	30 x 30	2.65	3.23	1414	474	75	63	51472E3	71472E3
	4700	25 x 40	2.89	3.53	1414	474	65	52	41472E3	21472E3
	6800	30 x 40	3.56	4.34	2044	684	53	45	51682E3	71682E3
	6800	25 x 50	3.75	4.58	2044	684	50	43	41682E3	21682E3
	10 000	35 x 40	4.05	4.94	3004	1004	49	42	51103E3	71103E3
	10 000	30 x 50	4.50	5.49	3004	1004	40	35	41103E3	21103E3
	15 000	35 x 50	4.98	6.08	4504	1504	39	33	51153E3	71153E3
63	1000	22 x 25	1.46	1.78	382	130	148	104	58102E3	78102E3
	1500	22 x 30	1.87	2.28	571	193	105	72	58152E3	78152E3
	2200	25 x 30	2.32	2.83	836	281	79	59	58222E3	78222E3
	2200	22 x 40	2.54	3.10	836	281	73	53	48222E3	28222E3
	3300	30 x 30	2.87	3.50	1251	420	64	50	58332E3	78332E3
	3300	25 x 40	3.14	3.83	1251	420	55	44	48332E3	28332E3
	4700	30 x 40	3.67	4.48	1780	596	50	38	58472E3	78472E3
	4700	25 x 50	3.71	4.53	1780	596	48	38	48472E3	28472E3
	6800	35 x 40	4.33	5.28	2574	861	43	38	58682E3	78682E3
	6800	30 x 50	4.75	5.80	2574	861	42	37	48682E3	28682E3
	10 000	35 x 50	5.26	6.42	3784	1264	35	30	58103E3	78103E3
100	470	22 x 25	0.77	0.94	286	98	535	470	59471E3	79471E3
	680	22 x 30	0.99	1.21	412	160	375	328	59681E3	79681E3
	1000	25 x 30	1.27	1.55	604	204	265	235	59102E3	79102E3
	1000	22 x 40	1.35	1.65	604	204	260	225	49102E3	29102E3
	1500	30 x 30	1.67	2.04	904	304	190	170	59152E3	79152E3
	1500	25 x 40	1.75	2.14	904	304	180	160	49152E3	29152E3
	2200	30 x 40	2.27	2.77	1324	444	130	120	59222E3	79222E3
	2200	25 x 50	2.30	2.80	1324	444	125	110	49222E3	29222E3
	3300	35 x 40	2.84	3.46	1984	664	100	95	59332E3	79332E3
	3300	30 x 50	2.97	3.62	1984	664	92	85	49332E3	29332E3
	4700	35 x 50	3.59	4.38	2824	677	75	70	59472E3	79472E3



Aluminum Capacitors
Power Standard Miniature Snap-In

Vishay BCcomponents

Table 3

ELECTRICAL DATA AND ORDERING INFORMATION FOR 057 SERIES									
U _R (V)	C _R 100 Hz (µF)	NOMINAL CASE SIZE Ø D x L (mm)	I _R 100 Hz 85 °C (A)	I _{L1} 1 min (µA)	I _{L5} 5 min (µA)	ESR 100 Hz (mΩ)	Z 10 kHz (mΩ)	ORDERING CODE MAL2057.....	
								2-TERM.	3-TERM.
200	150	22 x 25	0.77	184	64	950	620	52151E3	72151E3
	220	22 x 30	1.00	268	92	650	435	52221E3	72221E3
	330	25 x 30	1.36	400	136	430	310	52331E3	72331E3
	330	22 x 40	1.36	400	136	430	310	42331E3	22331E3
	470	30 x 30	1.80	568	192	310	230	52471E3	72471E3
	470	25 x 40	1.80	568	192	310	230	42471E3	22471E3
	680	30 x 40	2.39	820	276	210	180	52681E3	72681E3
	680	25 x 50	2.39	820	276	210	180	42681E3	22681E3
	1000	35 x 40	2.85	1204	404	160	135	52102E3	72102E3
	1000	30 x 50	2.85	1204	404	160	135	42102E3	22102E3
1500	35 x 50	3.66	1804	604	120	105	52152E3	72152E3	
250	100	22 x 25	0.63	154	54	1440	770	53101E3	73101E3
	150	22 x 30	0.83	229	79	960	520	53151E3	73151E3
	220	25 x 30	1.10	334	114	660	365	53221E3	73221E3
	220	22 x 40	1.10	334	114	660	365	43221E3	23221E3
	330	30 x 30	1.49	499	169	440	265	53331E3	73331E3
	330	25 x 40	1.49	499	169	440	265	43331E3	23331E3
	470	30 x 40	1.98	709	239	310	185	53471E3	73471E3
	470	25 x 50	1.98	709	239	310	185	43471E3	23471E3
	680	35 x 40	2.60	1024	344	240	145	53681E3	73681E3
	680	30 x 50	2.60	1024	344	240	145	43681E3	23681E3
1000	35 x 50	3.12	1504	504	160	105	53102E3	73102E3	
385	47	22 x 25	0.50	112	40	3000	1400	58479E3	78479E3
	68	22 x 30	0.63	161	56	2100	1000	58689E3	68689E3
	100	25 x 30	0.86	235	81	1400	780	58101E3	78101E3
	100	22 x 40	0.86	235	81	1400	780	48101E3	68101E3
	100	22 x 35	0.84	235	81	1400	780	38101E3	88101E3
	150	30 x 30	1.16	350	119	950	520	58151E3	78151E3
	150	25 x 40	1.16	350	119	950	520	48151E3	68151E3
	220	30 x 40	1.57	512	173	650	400	58221E3	78221E3
	220	30 x 35	1.50	512	173	650	400	38221E3	90051E3
	220	25 x 50	1.57	512	173	650	400	48221E3	68221E3
	330	35 x 35	1.73	766	258	480	280	68331E3	88331E3
	330	30 x 45	1.75	766	258	480	280	38331E3	78331E3
	470	35 x 50	2.40	1089	366	340	220	58471E3	78471E3
	470	35 x 45	2.29	1089	366	340	220	48471E3	28471E3
400	47	22 x 25	0.50	117	42	3000	1400	56479E3	76479E3
	68	22 x 30	0.63	167	58	2100	1000	56689E3	76689E3
	100	25 x 30	0.86	244	84	1400	780	56101E3	76101E3
	100	22 x 35	0.84	240	84	1400	780	36101E3	66101E3
	150	30 x 30	1.16	364	124	950	520	56151E3	90054E3
	150	25 x 40	1.16	364	124	950	520	46151E3	86151E3
	220	30 x 35	1.50	532	180	650	400	36221E3	90055E3
	220	25 x 50	1.57	532	180	650	400	46221E3	86221E3
	330	35 x 40	1.85	796	268	480	280	56331E3	76331E3
	330	30 x 50	1.85	796	268	480	280	46331E3	26331E3
	470	35 x 50	2.40	1132	380	340	220	56471E3	76471E3
	450	47	22 x 30	0.26	131	45	5600	4400	67479E3
68		22 x 30	0.33	188	65	3900	3100	57689E3	77689E3
100		30 x 30	0.48	274	94	2600	2100	57101E3	77101E3
100		25 x 35	0.46	274	94	2600	2100	37101E3	17101E3
150		30 x 35	0.66	409	140	1600	1300	37151E3	17151E3
150		25 x 50	0.70	409	140	1600	1300	47151E3	27151E3
220		35 x 40	0.92	598	202	1100	900	57221E3	77221E3
220		30 x 45	0.73	598	202	1100	900	37221E3	17221E3
330		35 x 50	1.26	895	301	700	600	57331E3	77331E3
330		35 x 45	1.20	895	301	700	600	47331E3	27331E3



ADDITIONAL ELECTRICAL DATA		
PARAMETER	CONDITIONS	VALUE
Voltage		
Surge voltage	≤ 250 V versions	$U_s = 1.15 \times U_R$
	≥ 385 V versions	$U_s = 1.1 \times U_R$
Reverse voltage		$U_{rev} \leq 1 \text{ V}$
Current		
Leakage current	After 1 minute at U_R	$I_{L1} \leq 0.006 C_R \times U_R + 4 \mu\text{A}$
	After 5 minutes at U_R	$I_{L5} \leq 0.002 C_R \times U_R + 4 \mu\text{A}$
Inductance		
Equivalent series inductance (ESL)	All case sizes	typ. 19 nH max. 25 nH

CAPACITANCE (C)

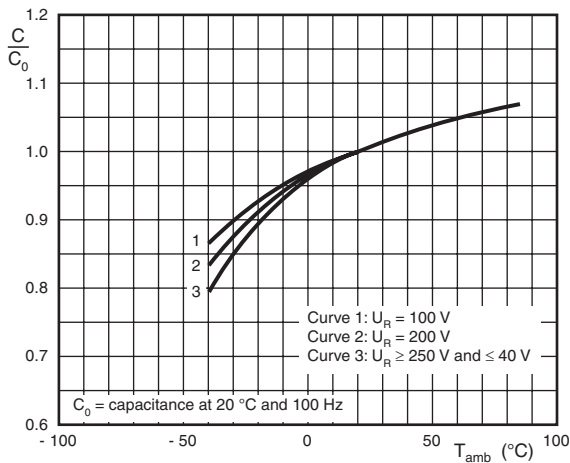


Fig.6 Typical multiplier of capacitance as a function of ambient temperature

EQUIVALENT SERIES RESISTANCE (ESR)

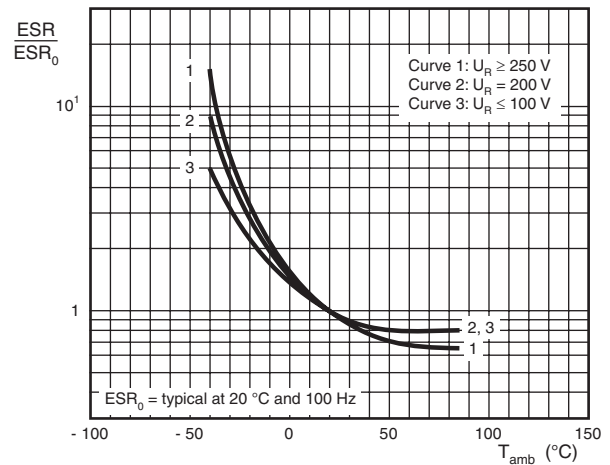


Fig.8 Typical multiplier of ESR as a function of ambient temperature

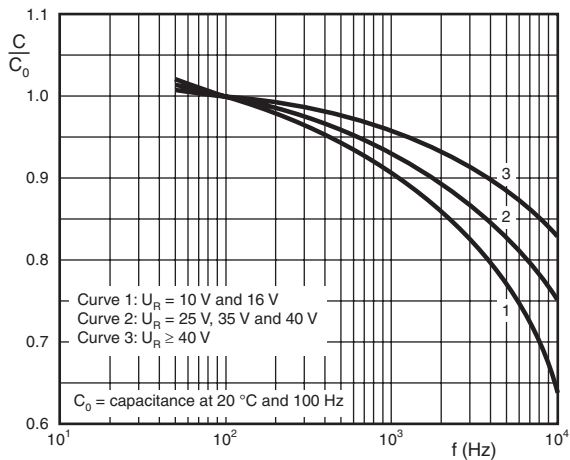


Fig.7 Typical multiplier of capacitance as a function of frequency

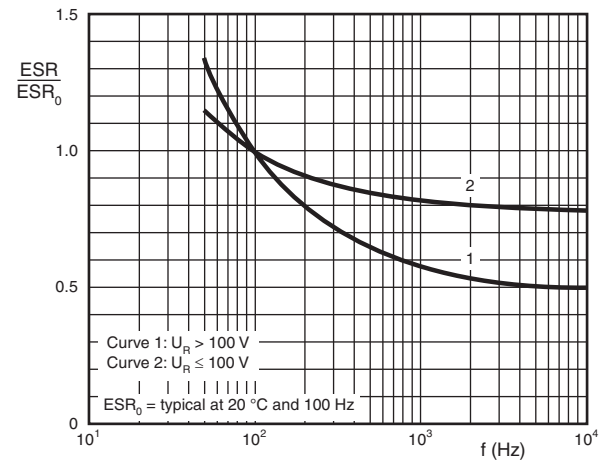


Fig.9 Typical multiplier of ESR as a function of frequency

IMPEDANCE (Z)

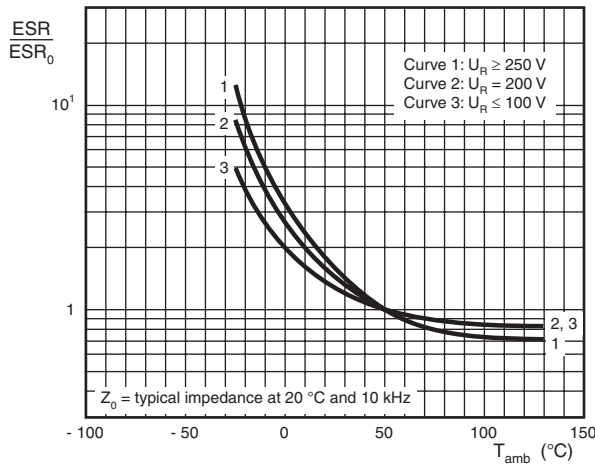


Fig.10 Typical multiplier of impedance as a function of ambient temperature

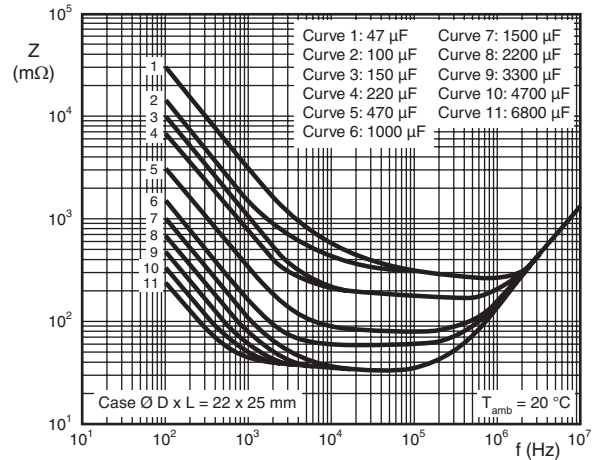


Fig.11 Typical impedance as a function of frequency

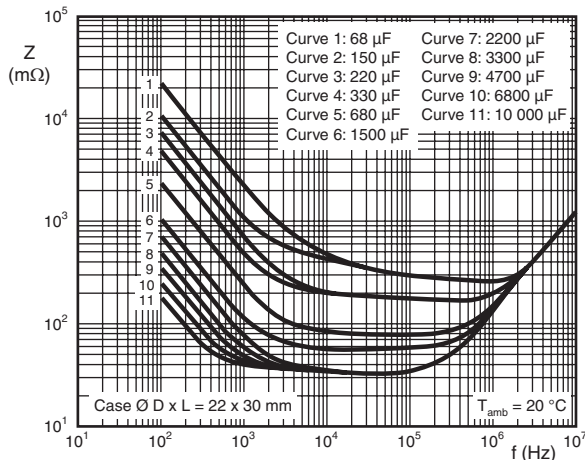


Fig.12 Typical impedance as a function of frequency

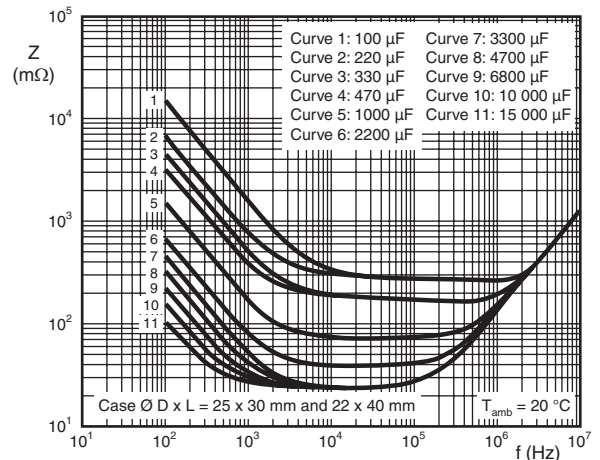


Fig.13 Typical impedance as a function of frequency

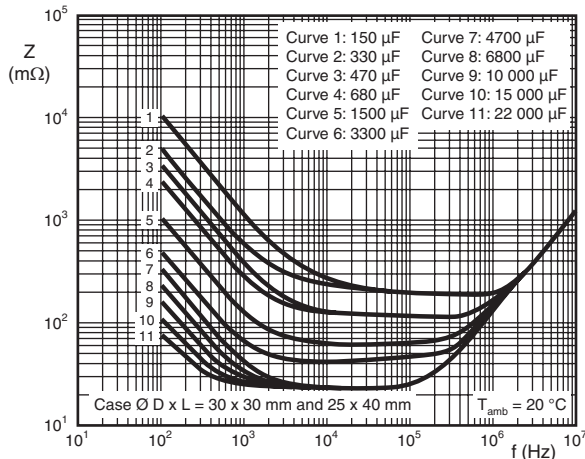


Fig.14 Typical impedance as a function of frequency

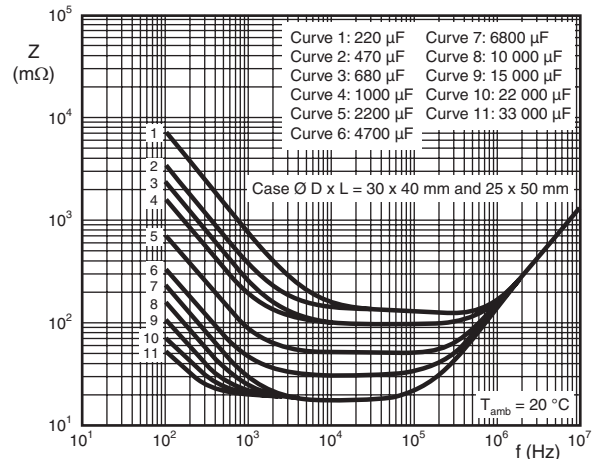


Fig.15 Typical impedance as a function of frequency

IMPEDANCE (Z)

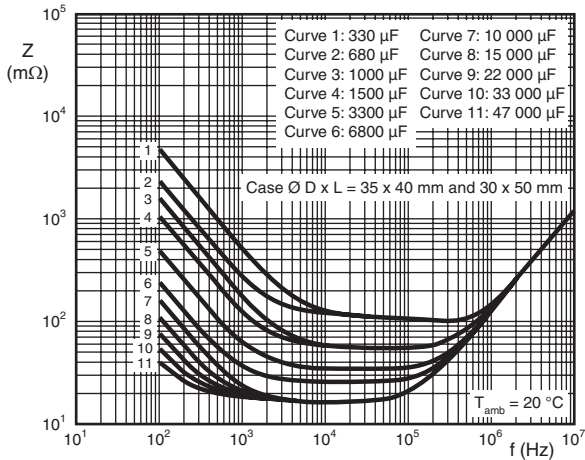


Fig.16 Typical impedance as a function of frequency

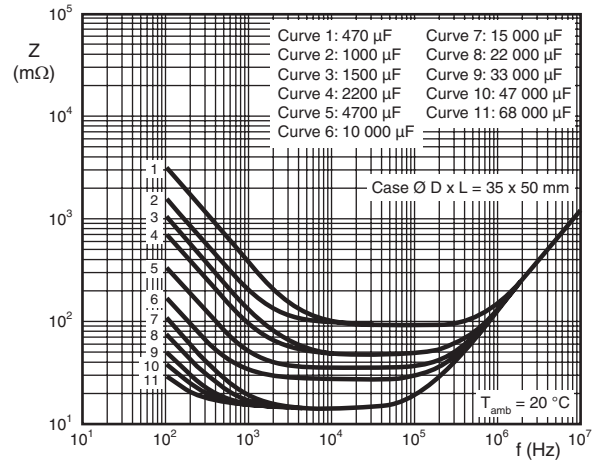
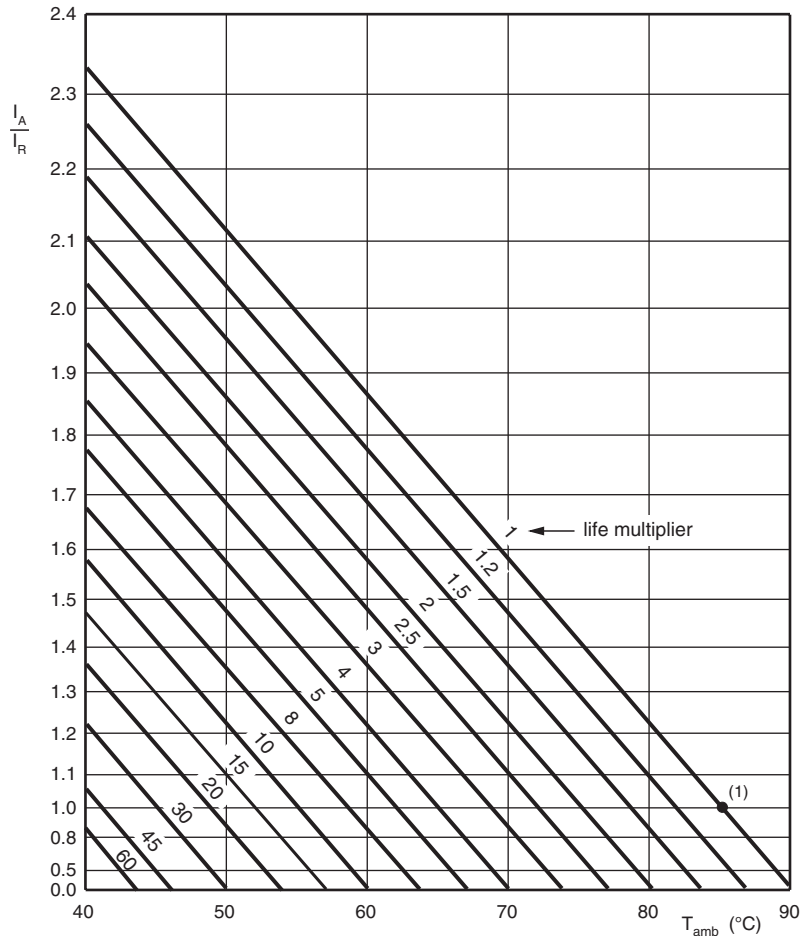


Fig.17 Typical impedance as a function of frequency

RIPPLE CURRENT AND USEFUL LIFE



I_A = actual ripple current at 100 Hz and 85 °C
 I_R = rated ripple current at 100 Hz and 85 °C
 (1) Useful life at 85 °C and I_R applied:
 12 000 hours (450 V types: 5000 hours)

Fig.18 Multiplier of useful life as a function of ambient temperature and ripple current load

Table 4

MULTIPLIER OF RIPPLE CURRENT (I_R) AS A FUNCTION OF FREQUENCY			
FREQUENCY (Hz)	I_R MULTIPLIER		
	$U_R = 10 \text{ V to } 25 \text{ V}$	$U_R = 40 \text{ V to } 100 \text{ V}$	$U_R > 100 \text{ V}$
50	0.93	0.91	0.86
100	1.00	1.00	1.00
200	1.04	1.05	1.13
400	1.07	1.09	1.21
1000	1.11	1.13	1.29
2000	1.13	1.15	1.32
4000	1.15	1.18	1.35
$\geq 10\,000$	1.18	1.22	1.40

Table 5

TEST PROCEDURES AND REQUIREMENTS			
TEST		PROCEDURE (quick reference)	REQUIREMENTS
NAME OF TEST	REFERENCE		
Endurance	IEC 60384-4/ EN130300 subclause 4.13	$T_{amb} = 85 \text{ }^\circ\text{C}$; U_R applied; 5000 hours (450 V types: 2000 hours)	$U_R \leq 100 \text{ V}$; $\Delta C/C$: $\pm 15 \%$ $U_R > 100 \text{ V}$; $\Delta C/C$: $\pm 10 \%$ $ESR \leq 1.3 \times \text{spec. limit}$ $Z \leq 2 \times \text{spec. limit}$ $I_{L5} \leq \text{spec. limit}$
Useful life	CECC 30301 subclause 1.8.1	$T_{amb} = 85 \text{ }^\circ\text{C}$; U_R and I_R applied; 12 000 hours (450 V types: 5000 hours)	$U_R \leq 100 \text{ V}$; $\Delta C/C$: $\pm 45 \%$ $U_R > 100 \text{ V}$; $\Delta C/C$: $\pm 30 \%$ $ESR \leq 3 \times \text{spec. limit}$ $Z \leq 3 \times \text{spec. limit}$ $I_{L5} \leq \text{spec. limit}$ no short or open circuit, no visible damage total failure percentage: $U_R \leq 100 \text{ V}$: $\leq 1 \%$; $U_R > 100 \text{ V}$: $\leq 3 \%$
Shelf life (storage at high temperature)	IEC 60384-4/ EN130300 subclause 4.17	$T_{amb} = 85 \text{ }^\circ\text{C}$; no voltage applied; 500 hours After test: U_R to be applied for 30 minutes 24 hours to 48 hours before measurement	$\Delta C/C$: $\pm 10 \%$ $ESR \leq 1.2 \times \text{spec. limit}$ $I_{L5} \leq 2 \times \text{spec. limit}$

Aluminum Capacitors Power High Ripple Current Snap-In

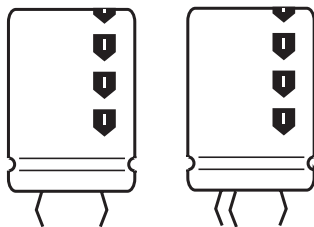


Fig.1 Component outlines



FEATURES

- Polarized aluminum electrolytic capacitors, non-solid electrolyte
- Large types, miniaturized dimensions, cylindrical aluminum case, insulated with a blue sleeve
- Very high ripple current capability
- Keyed polarity version available
- High reliability



RoHS
COMPLIANT

APPLICATIONS

- Motor control and industrial systems
- Smoothing and filtering
- Standard and switched mode power supplies
- Energy storage in pulse systems

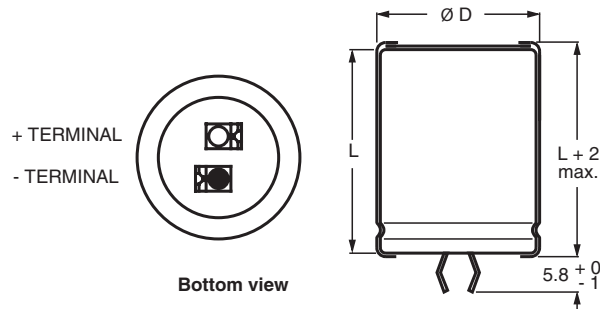
MARKING

The capacitors are marked (where possible) with the following information:

- Rated capacitance (in μF)
- Tolerance code on rated capacitance, code letter in accordance with IEC 60062 (M for $\pm 20\%$)
- Rated voltage (in V)
- Date code (YYMM)
- Name of manufacturer
- Code for factory of origin
- '-' sign to identify the negative terminal, visible from the top and side of the capacitor
- Code number
- Climatic category in accordance with IEC 60068

QUICK REFERENCE DATA	
DESCRIPTION	VALUE
Nominal case size (\varnothing D x L in mm)	22 x 25 to 35 x 60
Rated capacitance range (E6/E12 series), C_R	56 μF to 680 μF
Tolerance on C_R	$\pm 20\%$
Rated voltage range, U_R	400 V and 450 V
Category temperature range	- 25 °C to + 85 °C
Endurance test at 85 °C	7000 hours
Useful life at 85 °C	15 000 hours
Shelf life at 0 V, 85 °C	1000 hours
Based on sectional specification	IEC 60384-4/EN130300
Climatic category IEC 60068	25/085/56

SELECTION CHART FOR C_R , U_R AND RELEVANT NOMINAL CASE SIZES (\varnothing D x L in mm)		
C_R (μF)	U_R (V)	
	400	450
56	22 x 25	22 x 25
68	22 x 25	22 x 30
82	-	22 x 30
	-	25 x 25
100	22 x 30	22 x 35
	-	25 x 30
120	22 x 35	22 x 40
	25 x 30	25 x 30
	-	30 x 25
150	22 x 40	25 x 40
	25 x 35	30 x 30
180	25 x 40	25 x 40
	30 x 30	30 x 35
	35 x 25	35 x 25
220	25 x 45	25 x 50
	30 x 35	30 x 40
	35 x 30	35 x 30
270	30 x 40	30 x 45
	35 x 30	35 x 35
330	30 x 45	30 x 50
	35 x 35	35 x 40
390	30 x 50	35 x 45
	35 x 40	-
470	35 x 45	35 x 50
560	35 x 50	35 x 60
680	35 x 60	35 x 60

DIMENSIONS in millimeters AND AVAILABLE FORMS
TWO TERMINAL SNAP-IN


The minus terminal can be marked with a black dot or with an imprinted '-' sign.

Fig. 2 Two terminal snap-in

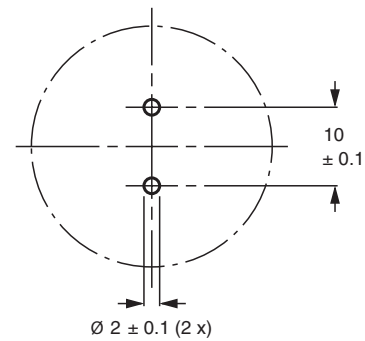
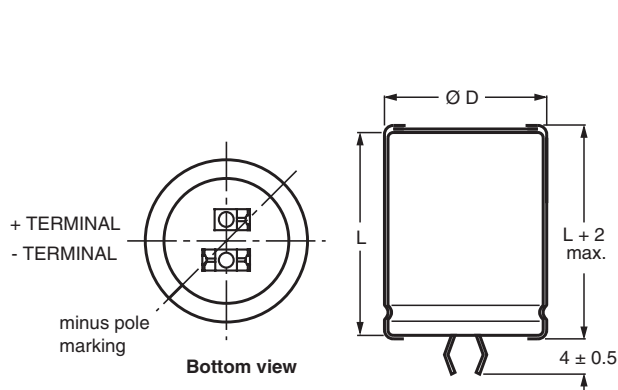
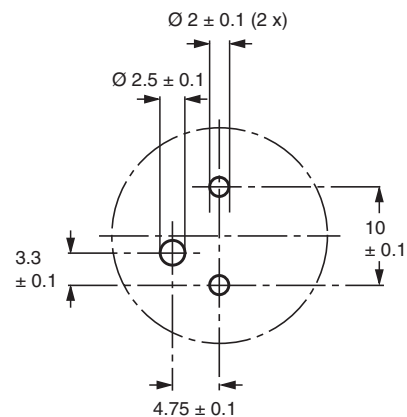


Fig. 3 Mounting hole diagram

THREE TERMINAL SNAP-IN


The negative terminal has **TWO** pins which are **BOTH** electrically connected.

Fig. 4 Three terminal snap-in



The 10 mm spacing of the 2 pin snap-in is used as the base layout and a third hole is added.

The third hole is closer to the negative primary hole so that polarization is always maintained, together with added mechanical stability.

Fig. 5 Mounting hole diagram

Table 1

DIMENSIONS in millimeters, MASS AND PACKAGING QUANTITIES					
NOMINAL CASE SIZE Ø D x L (mm)	Ø D_{max.}	L_{max.}	MASS (g)	PACKAGING QUANTITIES (units per box)	CARDBOARD BOX DIMENSIONS L x W x H
22 x 25	23	27	≈ 12	100	260 x 250 x 39
22 x 30	23	32	≈ 16	100	260 x 250 x 44
22 x 35	23	37	≈ 20	100	260 x 250 x 49
22 x 40	23	42	≈ 23	100	260 x 250 x 54
25 x 25	26	27	≈ 20	100	290 x 280 x 39
25 x 30	26	32	≈ 22	100	290 x 280 x 44
25 x 35	26	37	≈ 24	100	290 x 280 x 49
25 x 40	26	42	≈ 27	100	290 x 280 x 54
25 x 45	26	47	≈ 32	100	290 x 280 x 59
25 x 50	26	52	≈ 38	100	290 x 280 x 64
30 x 25	31	27	≈ 25	100	340 x 330 x 39
30 x 30	31	32	≈ 30	100	340 x 330 x 44
30 x 35	31	37	≈ 35	100	340 x 330 x 49
30 x 40	31	42	≈ 40	100	340 x 330 x 54
30 x 45	31	47	≈ 45	100	340 x 330 x 59
30 x 50	31	52	≈ 50	100	340 x 330 x 64
35 x 25	36	27	≈ 33	50	390 x 198 x 39
35 x 30	36	32	≈ 40	50	390 x 198 x 44
35 x 35	36	37	≈ 48	50	390 x 198 x 49
35 x 40	36	42	≈ 55	50	390 x 198 x 54
35 x 45	36	47	≈ 63	50	390 x 198 x 59
35 x 50	36	52	≈ 72	50	390 x 198 x 64
35 x 60	36	62	≈ 87	50	390 x 198 x 74

ELECTRICAL DATA	
SYMBOL	DESCRIPTION
C_R	rated capacitance at 100 Hz
I_R	rated RMS ripple current at 100 Hz, 85 °C
I_{L1}	max. leakage current after 1 minute at U _R
I_{L5}	max. leakage current after 5 minutes at U _R
ESR	typ./max. equivalent series resistance at 100 Hz
Z	typ./max. impedance at 10 kHz

Note

- Unless otherwise specified, all electrical values in table 2 apply at T_{amb} = 20 °C, P = 86 kPa to 106 kPa, RH = 45 % to 75 %

ORDERING EXAMPLE

Electrolytic capacitor 198 PHR-SI
470 µF/450 V; ± 20 %
Nominal case size: Ø 35 x 50 mm

2-terminal snap-in:

Ordering code: MAL2 198 57471 E3
Former 12NC: 2222 198 57471

3-terminal snap-in:

Ordering code: MAL2 198 77471 E3
Former 12NC: 2222 198 77471



Aluminum Capacitors
Power High Ripple Current Snap-In

Vishay BCcomponents

Table 2

ELECTRICAL DATA AND ORDERING INFORMATION											
U _R (V)	C _R 100 Hz (µF)	NOMINAL CASE SIZE Ø D x L (mm)	I _R 100 Hz 85 °C (A)	I _{L1} 1 min (µA)	I _{L5} 5 min (µA)	TYP. ESR 100 Hz (mΩ)	MAX. ESR 100 Hz (mΩ)	TYP. Z 10 kHz (mΩ)	MAX. Z 10 kHz (mΩ)	ORDERING CODE MAL2198.....	
										2-TERM.	3-TERM.
400	56	22 x 25	0.72	138	49	918	1706	521	1085	56569E3	76569E3
	68	22 x 25	0.79	167	59	762	1405	434	905	56689E3	76689E3
	100	22 x 30	1.00	244	84	520	956	297	610	56101E3	76101E3
	120	22 x 35	1.14	292	100	433	796	247	450	46121E3	26121E3
	120	25 x 30	1.14	292	100	438	796	252	450	36121E3	16121E3
	150	22 x 40	1.33	364	124	348	637	199	363	66151E3	86151E3
400	150	25 x 35	1.33	364	124	351	637	202	363	36151E3	16151E3
	180	25 x 40	1.51	436	148	293	531	169	295	36181E3	16181E3
	180	30 x 30	1.49	436	148	305	531	180	295	66181E3	86181E3
	180	35 x 25	1.56	436	148	327	531	200	295	26181E3	76181E3
	220	25 x 45	1.75	532	180	241	434	139	280	36221E3	90008E3
	220	30 x 35	1.56	532	180	250	434	147	280	26221E3	76221E3
	220	35 x 30	1.81	532	180	259	434	155	280	16221E3	86221E3
	270	30 x 40	1.95	652	220	205	354	121	263	36271E3	16271E3
	270	35 x 30	1.93	652	220	222	354	137	263	66271E3	86271E3
	330	30 x 45	2.22	796	268	169	290	101	210	36331E3	16331E3
	330	35 x 35	2.18	796	268	181	290	112	210	66331E3	86331E3
	390	30 x 50	2.50	940	316	145	245	86	175	36391E3	16391E3
	390	35 x 40	2.44	940	316	154	245	95	175	66391E3	86391E3
	470	35 x 45	2.72	1132	380	129	203	80	153	36471E3	16471E3
560	35 x 50	3.03	1348	452	110	171	70	133	46561E3	26561E3	
680	35 x 60	3.53	1636	548	91	140	57	110	46681E3	26681E3	
450	56	22 x 25	0.71	155	54.4	865	1706	479	940	57569E3	77569E3
	68	22 x 30	0.82	188	65.2	709	1405	392	765	57689E3	77689E3
	82	22 x 30	0.89	225	77.8	592	1165	329	645	47829E3	27829E3
	82	25 x 25	0.91	225	77.8	604	1165	339	645	57829E3	77829E3
	100	22 x 35	1.02	274	94	485	956	270	525	47101E3	27101E3
	100	25 x 30	1.05	274	94	491	956	274	525	57101E3	77101E3
	120	22 x 40	1.14	328	112	406	796	225	443	47121E3	27121E3
	120	25 x 30	1.13	328	112	415	796	233	443	57121E3	77121E3
	120	30 x 25	1.16	328	112	431	796	248	443	67121E3	87121E3
	150	25 x 40	1.36	409	139	328	637	184	353	47151E3	27151E3
	150	30 x 30	1.36	409	139	340	637	194	353	57151E3	77151E3
	180	25 x 40	1.47	490	166	277	531	157	303	47181E3	27181E3
	180	30 x 35	1.54	490	166	282	531	161	303	57181E3	77181E3
	180	35 x 25	1.46	490	166	316	531	191	303	67181E3	87181E3
	220	25 x 50	1.71	598	202	226	434	127	263	47221E3	27221E3
	220	30 x 40	1.75	598	202	232	434	133	263	57221E3	77221E3
	220	35 x 30	1.72	598	202	248	434	148	263	67221E3	87221E3
	270	30 x 45	1.98	733	247	191	354	110	225	47271E3	27271E3
	270	35 x 35	1.96	733	247	202	354	120	225	57271E3	77271E3
	330	30 x 50	2.22	895	301	158	290	91	195	47331E3	27331E3
	330	35 x 40	2.22	895	301	167	290	100	195	57331E3	77331E3
	390	35 x 45	2.46	1057	355	142	245	85	170	57391E3	77391E3
	470	35 x 50	2.73	1273	427	120	203	73	145	57471E3	77471E3
	560	35 x 60	3.10	1516	508	100	171	60	120	57561E3	77561E3
680	35 x 60	3.30	1840	616	88	140	55	110	57681E3	77681E3	

CUSTOMIZED PRODUCTS

If you are unable to find the capacitor you require, please contact your local Vishay BCcomponents sales organization; we are able to design and manufacture customized capacitors to meet your specific requirements.



ADDITIONAL ELECTRICAL DATA		
PARAMETER	CONDITIONS	VALUE
Voltage		
Surge voltage	≥ 400 V versions	$U_s = 1.1 \times U_R$
Reverse voltage		≤ 1 V
Current		
Leakage current	After 1 minute at U_R	$I_{L1} \leq 0.006 C_R \times U_R + 4 \mu A$
	After 5 minutes at U_R	$I_{L5} \leq 0.002 C_R \times U_R + 4 \mu A$
Inductance		
Equivalent series inductance (ESL)	All case sizes	typ. 19 nH
		max. 25 nH

Table 3

MULTIPLIER OF RIPPLE CURRENT (I_R) AS A FUNCTION OF FREQUENCY	
FREQUENCY (Hz)	I_R MULTIPLIER
50	0.86
100	1.00
300	1.17
600	1.24
1000	1.29
≥ 10 000	1.40

RIPPLE CURRENT AND USEFUL LIFE

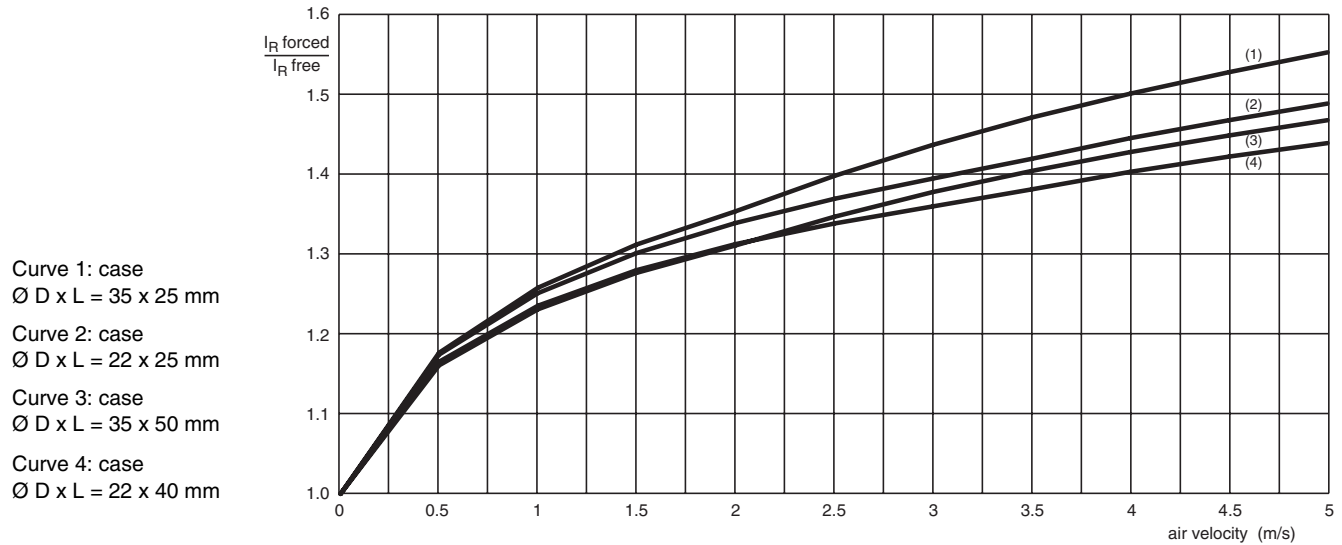


Fig. 6 Multiplier of ripple current (I_R) as a function of air-flow

MAXIMUM RIPPLE CURRENT MULTIPLIER			
PARAMETER	CONDITION	MAXIMUM RIPPLE CURRENT MULTIPLIER	VALUE
Ambient temperature (T_{amb})	70 °C	from nomogram; see Fig.7	1.57
Operating frequency (f)	300 Hz	from frequency table; see Table	1.17
Air-flow	2 m/s	from air-flow; see Fig.6	1.35

Note

Calculation example for case $\varnothing D \times L = 35 \times 25$ mm

Therefore the maximum ripple current multiplier at 70 °C, 300 Hz and 2 m/s air-flow = 1.57 x 1.17 x 1.35 = 2.48.

MGA 453

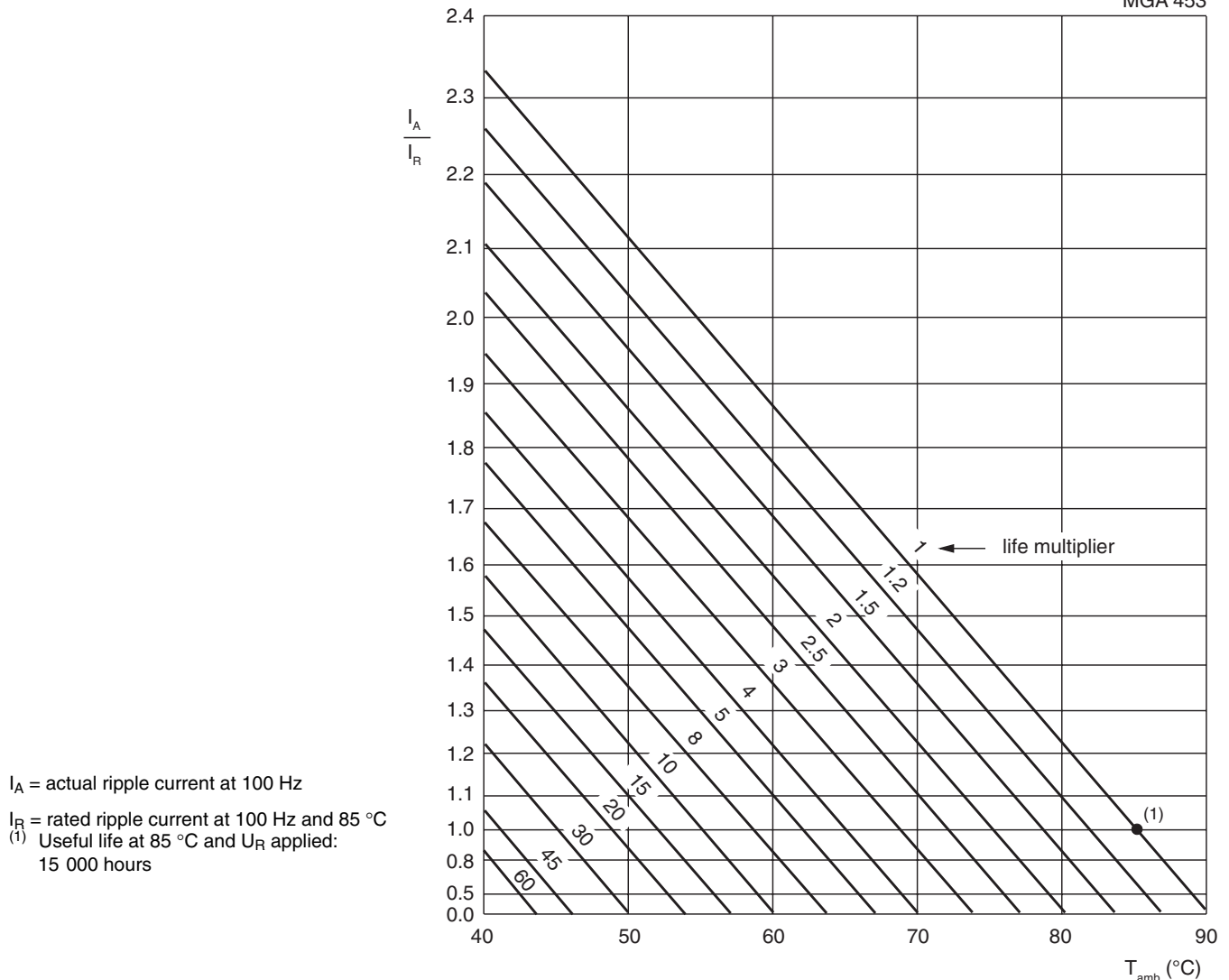


Fig. 7 Multiplier of useful life as a function of ambient temperature and ripple current load

Table 4

TEST PROCEDURES AND REQUIREMENTS			
TEST		PROCEDURE (quick reference)	REQUIREMENTS
NAME OF TEST	REFERENCE		
Endurance	IEC 60384-4/ EN130300 subclause 4.13	$T_{amb} = 85\text{ °C}$; U_R applied; 7000 hours	$\Delta C/C: \pm 10\%$ $ESR \leq 2 \times \text{spec. limit}$ $IL5 \leq \text{spec. limit}$
Useful life	CECC 30301 subclause 1.8.1	$T_{amb} = 85\text{ °C}$; U_R and I_R applied; 15 000 hours	$\Delta C/C: \pm 30\%$ $ESR \leq 3 \times \text{spec. limit}$ $IL5 \leq \text{spec. limit}$
Shelf life (storage at high temperature)	IEC 60384-4/ EN130300 subclause 4.17	$T_{amb} = 85\text{ °C}$; no voltage applied; 1000 hours after test: U_R to be applied for 30 minutes, 24 hours to 48 hours before measurement	$\Delta C/C: \pm 15\%$ $ESR \leq 2 \times \text{spec. limit}$ $IL5 \leq 2 \times \text{spec. limit}$

Aluminum Capacitors Power Miniaturized Economy Long Life Snap-In

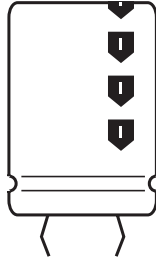
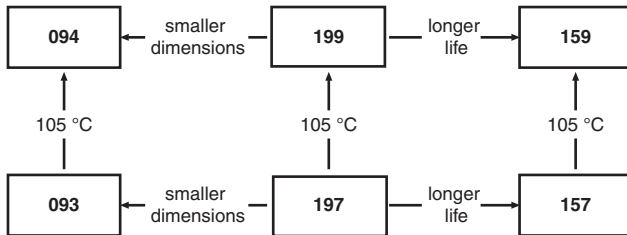


Fig.1 Component outlines



QUICK REFERENCE DATA	
DESCRIPTION	VALUE
Nominal case size (Ø D x L in mm)	22 x 25 to 35 x 60
Rated capacitance range, C _R	56 µF to 2200 µF
Tolerance on C _R	± 20 %
Rated voltage range, U _R	200 V to 450 V
Category temperature range	- 25 °C to + 105 °C
Useful life at 105 °C	2000 hours
Useful life at 40 °C and 1.6 x I _R applied	180 000 hours
Shelf life at 0 V, 105 °C	500 hours
Based on sectional specification	IEC 60384-4/EN130300/W of JISC5141

FEATURES

- Polarized aluminum electrolytic capacitors, non-solid electrolyte
- Large types, miniaturized dimensions, cylindrical aluminum case, insulated with a blue sleeve
- Useful life: 2000 hours at 105 °C



RoHS
COMPLIANT

APPLICATIONS

- Consumer and Telecom
- Whitegood motor control
- Electronic drives
- Smmps/ups

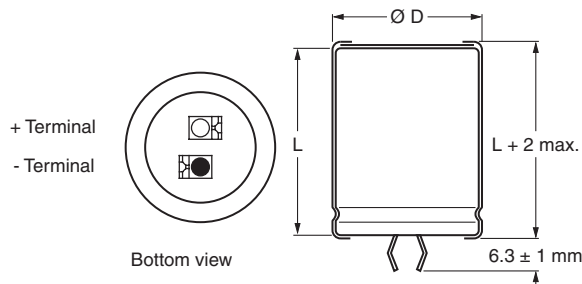
MARKING

The capacitors are marked (where possible) with the following information:

- Rated capacitance (in µF)
- Tolerance code on rated capacitance, code letter in accordance with IEC 60062 (M for ± 20 %)
- Rated voltage (in V)
- Name of manufacturer
- Date code
- '-' sign to identify the negative terminal, visible from the top and side of the capacitor
- Code number (last 8 digits)
- Maximum operating temperature

SELECTION CHART FOR C _R , U _R AND RELEVANT NOMINAL CASE SIZES (Ø D x L in mm)					
C _R (µF)	U _R (V)				
	200	250	400	420	450
56	-	-	22 x 25	22 x 25	22 x 25
68	-	-	22 x 25	22 x 25	22 x 25
82	-	-	22 x 25	22 x 25	22 x 30
	-	-	-	-	25 x 25
100	-	-	22 x 25	22 x 30	22 x 30
	-	-	-	25 x 25	25 x 25
120	-	-	22 x 30	22 x 30	22 x 35
	-	-	25 x 25	25 x 25	25 x 30
150	-	-	22 x 35	22 x 35	22 x 40
	-	-	-	25 x 30	25 x 30
	-	-	-	-	30 x 25

SELECTION CHART FOR C_R, U_R AND RELEVANT NOMINAL CASE SIZES ($\varnothing D \times L$ in mm)					
C_R (μF)	U_R (V)				
	200	250	400	420	450
180	-	-	30 x 25	22 x 40	22 x 50
	-	-	-	25 x 30	25 x 35
	-	-	-	30 x 25	30 x 25
220	22 x 25	22 x 30	22 x 50	22 x 50	25 x 40
	-	-	25 x 35	25 x 40	30 x 30
	-	-	30 x 25	30 x 30	35 x 25
	-	-	-	35 x 25	-
270	22 x 25	22 x 30	30 x 30	25 x 50	25 x 50
	-	-	35 x 25	-	30 x 35
	-	-	-	-	35 x 30
330	22 x 30	22 x 35	25 x 50	35 x 30	30 x 45
	-	-	30 x 35	-	35 x 35
	-	-	35 x 30	-	-
390	22 x 35	25 x 30	30 x 40	35 x 35	30 x 50
	25 x 30	-	35 x 30	-	35 x 40
470	22 x 35	25 x 35	30 x 45	35 x 40	35 x 45
	25 x 30	-	35 x 35	-	-
560	25 x 30	25 x 40	30 x 50	35 x 45	35 x 50
	-	-	35 x 40	-	-
680	22 x 50	30 x 30	35 x 45	35 x 50	35 x 60
	25 x 40	-	-	-	-
820	30 x 30	-	-	-	-
1000	25 x 50	30 x 45	-	-	-
	30 x 35	-	-	-	-
1200	30 x 40	35 x 40	-	-	-
	30 x 50	35 x 45	-	-	-
1500	35 x 40	-	-	-	-
	-	35 x 50	-	-	-
1800	-	-	-	-	-
2200	35 x 50	-	-	-	-

DIMENSIONS in millimeters AND AVAILABLE FORMS


The minus and/or plus terminal can be marked with an imprinted sign.

Fig.2 Two terminal snap-in

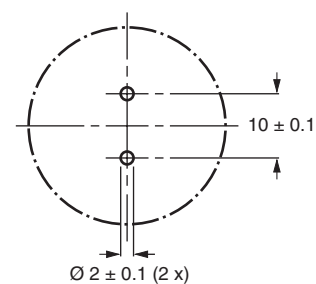


Fig.3 Mounting hole diagram

Table 1

DIMENSIONS in millimeters, MASS AND PACKAGING QUANTITIES					
NOMINAL CASE SIZE Ø D x L	Ø D_{max.}	L_{max.}	MASS (g)	PACKAGING QUANTITIES	CARDBOARD BOX DIMENSIONS L x W x H
22 x 25	22.5	25.5	≈ 12	216	280 x 240 x 140
22 x 30	22.5	30.5	≈ 16	216	280 x 240 x 140
22 x 35	22.5	35.5	≈ 20	144	280 x 240 x 105
22 x 40	22.5	40.5	≈ 23	144	280 x 240 x 105
22 x 45	22.5	45.5	≈ 26	144	280 x 240 x 140
22 x 50	22.5	50.5	≈ 29	72	280 x 240 x 105
25 x 25	25.5	25.5	≈ 20	216	280 x 240 x 140
25 x 30	25.5	32.0	≈ 22	216	280 x 240 x 140
25 x 35	25.5	35.5	≈ 24	144	280 x 240 x 105
25 x 40	25.5	40.5	≈ 27	144	280 x 240 x 105
25 x 45	25.5	45.5	≈ 32	144	280 x 240 x 140
25 x 50	25.5	50.5	≈ 38	144	280 x 240 x 140
30 x 25	30.5	27.5	≈ 25	168	280 x 240 x 140
30 x 30	30.5	32.5	≈ 30	168	280 x 240 x 140
30 x 35	30.5	37.5	≈ 35	112	280 x 240 x 105
30 x 40	30.5	41.5	≈ 40	112	280 x 240 x 105
30 x 45	30.5	46.5	≈ 45	112	280 x 240 x 140
30 x 50	30.5	51.5	≈ 50	112	280 x 240 x 140
35 x 25	35.5	25.5	≈ 33	126	280 x 240 x 140
35 x 30	35.5	32.5	≈ 40	126	280 x 240 x 140
35 x 35	35.5	35.5	≈ 48	84	280 x 240 x 105
35 x 40	35.5	41.5	≈ 55	84	280 x 240 x 105
35 x 45	35.5	46.5	≈ 63	84	280 x 240 x 140
35 x 50	35.5	51.5	≈ 72	84	280 x 240 x 140
35 x 60	35.5	61.5	≈ 87	42	280 x 240 x 105

ELECTRICAL DATA	
SYMBOL	DESCRIPTION
C_R	rated capacitance at 120 Hz
I_R	rated RMS ripple current at 120 Hz, 105 °C
I_{L5}	max. leakage current after 5 minutes at U _R
ESR	max. equivalent series resistance at 120 Hz ⁽¹⁾

Note

- (1) ESR at 100 Hz is approximately 1.05 x ESR 120 Hz
- Unless otherwise specified, all electrical values in table 2 apply at T_{amb} = 20 °C, P = 86 kPa to 106 kPa, RH = 45 % to 75 %

ORDERING EXAMPLE

Electrolytic capacitor 094 series
 330 µF/400 V; ± 20 %
 Nominal case size: Ø 25 x 50 mm
 2-terminal snap-in:
 Ordering code: MAL209446331 E3
 Former 12NC: 222209446331



Aluminum Capacitors
Power Miniaturized Economy Long Life Snap-In

Vishay BCcomponents

Table 2

ELECTRICAL DATA AND ORDERING INFORMATION							
U _R (V)	C _R 120 Hz (µF)	NOMINAL CASE SIZE Ø D x L (mm)	I _R 120 Hz (A)	I _{L5} (mA)	MAX. ESR 120 Hz ⁽¹⁾ (Ω)	MAX. Z 10 kHz (Ω)	ORDERING CODE MAL2094.....
200	220	22 x 25	1.04	0.88	0.46	0.30	52221E3
	270	22 x 25	1.12	1.08	0.40	0.26	52271E3
	330	22 x 30	1.30	1.32	0.32	0.21	52331E3
	390	22 x 35	1.49	1.50	0.27	0.17	52391E3
	390	25 x 30	1.47	1.50	0.27	0.18	42391E3
	470	22 x 35	1.58	1.50	0.24	0.15	52471E3
	470	25 x 30	1.55	1.50	0.24	0.16	42471E3
	560	25 x 30	1.61	1.50	0.22	0.15	42561E3
	680	22 x 50	1.96	1.50	0.16	0.10	52681E3
	680	25 x 40	1.98	1.50	0.17	0.11	42681E3
	820	30 x 30	1.86	1.50	0.18	0.13	32821E3
	1000	25 x 50	2.56	1.50	0.12	0.08	42102E3
	1000	30 x 35	2.04	1.50	0.16	0.12	32102E3
	1200	30 x 40	2.35	1.50	0.13	0.09	32122E3
	1500	30 x 50	2.87	1.50	0.10	0.07	32152E3
1500	35 x 40	2.54	1.50	0.13	0.09	22152E3	
2200	35 x 50	3.02	1.50	0.10	0.07	22222E3	
250	220	22 x 30	1.33	1.10	0.41	0.25	53221E3
	270	22 x 30	1.22	1.35	0.35	0.22	53271E3
	330	22 x 35	1.40	1.50	0.29	0.18	53331E3
	390	25 x 30	1.46	1.50	0.26	0.17	43391E3
	470	25 x 35	1.64	1.50	0.22	0.14	43471E3
	560	25 x 40	1.87	1.50	0.19	0.12	43561E3
	680	30 x 30	1.76	1.50	0.20	0.14	33681E3
	1000	30 x 45	2.48	1.50	0.13	0.09	33102E3
	1200	35 x 40	2.47	1.50	0.13	0.10	23122E3
	1500	35 x 45	2.73	1.50	0.12	0.09	23152E3
1800	35 x 50	2.96	1.50	0.10	0.07	23182E3	
400	56	22 x 25	0.53	0.45	2.39	1.79	56569E3
	68	22 x 25	0.58	0.54	1.98	1.49	56689E3
	82	22 x 25	0.64	0.66	1.66	1.25	56829E3
	100	22 x 25	0.68	0.80	1.51	1.16	56101E3
	120	22 x 30	0.79	0.96	1.16	0.87	56121E3
	120	25 x 25	0.79	0.96	1.17	0.89	46121E3
	150	22 x 35	0.92	1.20	0.92	0.69	56151E3
	180	30 x 25	1.03	1.44	0.81	0.62	36181E3
	220	22 x 50	1.15	1.50	0.59	0.44	56221E3
	220	25 x 35	1.11	1.50	0.68	0.52	46221E3
	220	30 x 25	1.08	1.50	0.71	0.55	36221E3
	270	30 x 30	1.26	1.50	0.55	0.42	36271E3
	270	35 x 25	1.25	1.50	0.63	0.50	26271E3
	330	25 x 50	1.61	1.50	0.43	0.33	46331E3
	330	30 x 35	1.41	1.50	0.47	0.37	36331E3
	330	35 x 30	1.50	1.50	0.46	0.36	26331E3
	390	30 x 40	1.62	1.50	0.39	0.30	36391E3
	390	35 x 30	1.56	1.50	0.43	0.34	26391E3
	470	30 x 45	1.82	1.50	0.33	0.26	36471E3
	470	35 x 35	1.70	1.50	0.37	0.30	26471E3
	560	30 x 50	2.03	1.50	0.29	0.23	36561E3
560	35 x 40	1.95	1.50	0.30	0.24	26561E3	
680	35 x 45	2.15	1.50	0.26	0.21	26681E3	

ELECTRICAL DATA AND ORDERING INFORMATION							
U_R (V)	C_R 120 Hz (μ F)	NOMINAL CASE SIZE \varnothing D x L (mm)	I_R 120 Hz (A)	I_{L5} (mA)	MAX. ESR 120 Hz ⁽¹⁾ (Ω)	MAX. Z 10 kHz (Ω)	ORDERING CODE MAL2094.....
420	56	22 x 25	0.54	0.47	2.24	1.64	54569E3
	68	22 x 25	0.59	0.57	1.86	1.36	54689E3
	82	22 x 25	0.64	0.69	1.60	1.20	54829E3
	100	22 x 30	0.74	0.84	1.27	0.93	54101E3
	100	25 x 25	0.74	0.84	1.29	0.96	44101E3
	120	22 x 30	0.79	1.01	1.15	0.87	54121E3
	120	25 x 25	0.79	1.01	1.16	0.89	44121E3
	150	22 x 35	0.92	1.26	0.91	0.69	54151E3
	150	25 x 30	0.93	1.26	0.86	0.64	44151E3
	180	22 x 40	1.06	1.50	0.76	0.57	54181E3
	180	25 x 30	1.00	1.50	0.78	0.59	44181E3
	180	30 x 25	1.03	1.50	0.76	0.58	34181E3
	220	22 x 50	1.15	1.50	0.59	0.44	54221E3
	220	25 x 40	1.22	1.50	0.59	0.44	44221E3
	220	30 x 30	1.19	1.50	0.59	0.44	34221E3
	220	35 x 25	1.19	1.50	0.67	0.52	24221E3
	270	25 x 50	1.50	1.50	0.47	0.34	44271E3
	330	35 x 30	1.49	1.50	0.45	0.35	24331E3
	390	35 x 35	1.65	1.50	0.39	0.31	24391E3
	470	35 x 40	1.86	1.50	0.32	0.25	24471E3
560	35 x 45	2.06	1.50	0.27	0.21	24561E3	
680	35 x 50	2.30	1.50	0.23	0.18	24681E3	
450	56	22 x 25	0.55	0.50	2.06	1.46	57569E3
	68	22 x 25	0.59	0.61	1.72	1.23	57689E3
	82	22 x 30	0.68	0.74	1.41	1.01	57829E3
	82	25 x 25	0.68	0.74	1.43	1.03	47829E3
	100	22 x 30	0.74	0.90	1.25	0.92	57101E3
	100	25 x 25	0.74	0.90	1.25	0.91	47101E3
	120	22 x 35	0.85	1.08	1.01	0.73	57121E3
	120	25 x 30	0.86	1.08	0.98	0.70	47121E3
	150	22 x 40	0.99	1.35	0.81	0.59	57151E3
	150	25 x 30	0.93	1.35	0.83	0.61	47151E3
	150	30 x 25	0.97	1.35	0.83	0.61	37151E3
	180	22 x 50	1.07	1.50	0.64	0.45	57181E3
	180	25 x 35	1.05	1.50	0.73	0.53	47181E3
	180	30 x 25	1.03	1.50	0.75	0.56	37181E3
	220	25 x 40	1.20	1.50	0.60	0.44	47221E3
	220	30 x 30	1.19	1.50	0.59	0.43	37221E3
	220	35 x 25	1.19	1.50	0.67	0.51	27221E3
	270	25 x 50	1.50	1.50	0.47	0.34	47271E3
	270	30 x 35	1.34	1.50	0.50	0.38	37271E3
	270	35 x 30	1.42	1.50	0.49	0.37	27271E3
	330	30 x 45	1.64	1.50	0.38	0.28	37331E3
	330	35 x 35	1.58	1.50	0.42	0.32	27331E3
	390	30 x 50	1.85	1.50	0.33	0.25	37391E3
	390	35 x 40	1.78	1.50	0.35	0.26	27391E3
	470	35 x 45	1.97	1.50	0.29	0.22	27471E3
	560	35 x 50	2.20	1.50	0.25	0.19	27561E3
	680	35 x 60	2.60	1.50	0.21	0.16	27681E3

Note⁽¹⁾ ESR at 100 Hz is approximately 1.05 x ESR 120 Hz



ADDITIONAL ELECTRICAL DATA		
PARAMETER	CONDITIONS	VALUE
Voltage		
Surge voltage	≥ 200 V versions	$U_s = 1.1 \times U_R$
Reverse voltage	≤ 1 V	-
Current		
Leakage current	After 5 minutes at U_R	$I_{L5} \leq 0.02 C_R \times U_R$ or 1.5 mA, whichever is smaller
Inductance		
Equivalent series inductance (ESL)	All case sizes	19 nH typical/25 nH max.

Table 3

LOW TEMPERATURE CHARACTERISTIC (at 120 Hz)		
DESCRIPTION	Z (-25 °C)/Z (+20 °C)	U_R (V) ⁽¹⁾
		200 to 450
Impedance ratio	Z (-25 °C)/Z (+20 °C)	4

Note

⁽¹⁾ Impedance ratio shall not exceed the given values

RIPPLE CURRENT AND USEFUL LIFE

I_A = actual ripple current at 120 Hz
 I_R = rated ripple current at 120 Hz and 105 °C
⁽¹⁾ Useful life at 105 °C and I_R applied: 2000 hours

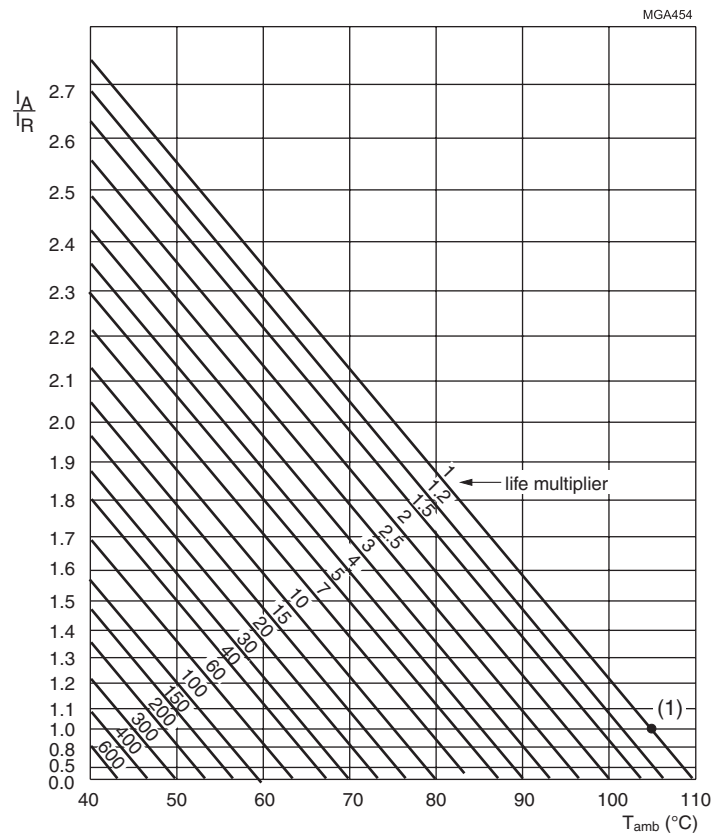


Fig.4 Multiplier of useful life as a function of ambient temperature and ripple current load



Table 4

MULTIPLIER OF RIPPLE CURRENT (I_R) AS A FUNCTION OF FREQUENCY	
FREQUENCY (Hz)	IR MULTIPLIER
60	0.90
100	0.95
120	1.00
500	1.20
1000	1.30
$\geq 10\ 000$	1.40

Table 5

TEST PROCEDURES AND REQUIREMENTS			
TEST		PROCEDURE (quick reference)	REQUIREMENTS
NAME OF TEST	REFERENCE		
Useful life	CECC 30301 subclause 1.8.1	$T_{amb} = 105\ ^\circ\text{C}$; U_R and I_R applied: 2000 hours	$\Delta C/C: \pm 30\ \%$ $ESR \leq 3 \times \text{spec. limit}$, $I_{L5} \leq \text{spec. limit}$ no short or open circuit, no visible damage, total failure percentage: $\leq 3\ \%$
Shelf life (storage at high temperature)	IEC 60384-4/ EN130300 subclause 4.17	$T_{amb} = 105\ ^\circ\text{C}$; no voltage applied; 500 hours After test: U_R to be applied for 30 minutes, 24 hours to 48 hours before measurement	$\Delta C/C: \pm 20\ \%$ $ESR \leq 2 \times \text{spec. limit}$ $I_{L5} \leq 1 \times \text{spec. limit}$

Aluminum Capacitors Power Ultra Long Life Snap-In

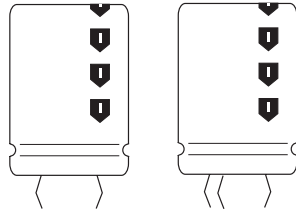


Fig.1 Component outlines



QUICK REFERENCE DATA

DESCRIPTION	VALUE
Nominal case sizes (Ø D x L in mm)	22 x 25 to 35 x 40
Rated capacitance range (E6/E12 series), C _R	560 µF to 47 000 µF
Tolerance on C _R	± 20 %
Rated voltage range, U _R	25 V to 100 V
Category temperature range	- 40 °C to + 105 °C
Endurance test at 105 °C	2000 hours
Useful life at 105 °C	5000 hours
Useful life at 40 °C, 1.9 x I _R applied	125 000 hours
Shelf life at 0 V, 105 °C	500 hours
Based on sectional specification	IEC 60384-4/EN130300
Climatic category IEC 60068	40/105/56

FEATURES

- Polarized aluminum electrolytic capacitors, non-solid electrolyte
- Large types, very small dimensions, cylindrical aluminum case, insulated with a blue sleeve
- Low ESR, high ripple current capability
- Long useful life: up to 5000 hours at 105 °C
- Keyed polarity version available


**RoHS
COMPLIANT**

APPLICATIONS

- General purpose, industrial, telecom and audio/video systems
- Smoothing and filtering
- Standard and switched mode power supplies
- Energy storage in pulse systems

MARKING

The capacitors are marked (where possible) with the following information:

- Rated capacitance (in µF)
- Tolerance on rated capacitance, code letter in accordance with IEC 60062 (M for ± 20 %)
- Rated voltage (in V)
- Date code (YYMM)
- Name of manufacturer
- Code for factory of origin
- ‘-’ sign to identify the negative terminal, visible from the top and side of the capacitor
- Code number
- Climatic category in accordance with IEC 60068

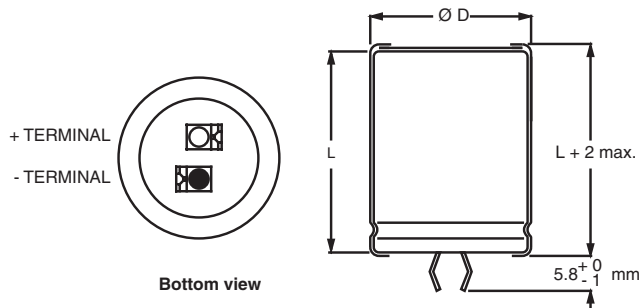
SELECTION CHART FOR C_R, U_R AND RELEVANT NOMINAL CASE SIZES (Ø D x L in mm)

C _R (µF)	U _R (V)							
	16	25	35	40	50	63	80	100
560	-	-	-	-	-	-	-	22 x 25
680	-	-	-	-	-	-	22 x 25	22 x 30
1000	-	-	-	-	-	-	22 x 30	25 x 30
1200	-	-	-	-	-	-	25 x 30	-
1500	-	-	-	-	-	22 x 25	-	25 x 40 30 x 30
1800	-	-	-	-	-	-	-	30 x 35
2200	-	-	-	-	22 x 25	22 x 30	25 x 40 30 x 30	30 x 40
2700	-	-	-	-	-	25 x 30	30 x 35	-
3300	-	-	-	22 x 25	22 x 30	25 x 40	30 x 40	35 x 40
3900	-	-	-	22 x 30	25 x 30	25 x 40 30 x 30	-	-
4700	-	22 x 25	22 x 30	22 x 30	25 x 30 25 x 40	30 x 30 30 x 35	35 x 40	-
5600	-	-	-	25 x 30	25 x 40	30 x 35	-	-
6800	22 x 25	22 x 30	25 x 30	25 x 40	30 x 30	30 x 40	-	-
8200	-	25 x 30	-	30 x 30	30 x 35	35 x 40	-	-
10 000	22 x 30	25 x 40	25 x 40 30 x 30	30 x 35 30 x 40	30 x 40	-	-	-

SELECTION CHART FOR C_R , U_R AND RELEVANT NOMINAL CASE SIZES ($\varnothing D \times L$ in mm)								
C_R (μF)	U_R (V)							
	16	25	35	40	50	63	80	100
12 000	-	25 x 40 30 x 30	-	-	-	-	-	-
15 000	25 x 30	30 x 35 30 x 40	30 x 40	35 x 40	-	-	-	-
18 000	-	-	-	35 x 40	-	-	-	-
22 000	25 x 40 30 x 30	35 x 40	35 x 40	-	-	-	-	-
27 000	30 x 35	-	-	-	-	-	-	-
33 000	30 x 40	-	-	-	-	-	-	-
39 000	-	-	-	-	-	-	-	-
47 000	30 x 40 35 x 40	-	-	-	-	-	-	-

DIMENSIONS in millimeters **AND AVAILABLE FORMS**

TWO TERMINAL SNAP-IN



The minus terminal can be marked with a black dot or with an imprinted '-' sign.

Fig.2 Two terminal snap-in

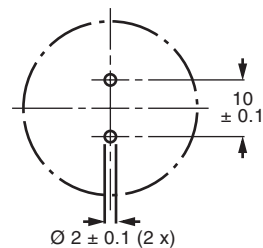
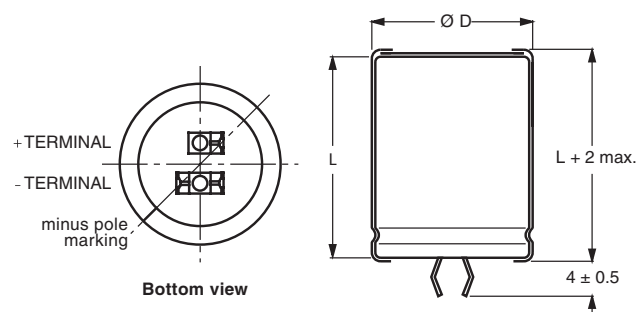


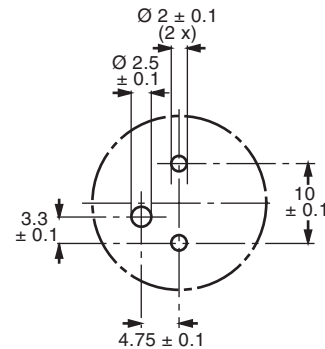
Fig.3 Mounting hole diagram

THREE TERMINAL SNAP-IN



The negative terminal has **TWO** pins which are **BOTH** electrically connected.

Fig.4 Three terminal snap-in



The 10 mm spacing of the 2 pin snap-in is used as the base layout and a third hole is added.

The third hole is closer to the negative primary hole so that polarization is always maintained, together with added mechanical stability.

Fig.5 Mounting hole diagram



Table 1

DIMENSIONS in millimeters, MASS AND PACKAGING QUANTITIES					
NOMINAL CASE SIZE Ø D x L	Ø D _{max.}	L _{max.}	MASS (g)	PACKAGING QUANTITIES (units per box)	CARDBOARD BOX DIMENSIONS L x W x H (mm)
22 x 25	23	27	12	100	260 x 250 x 39
22 x 30	23	32	16	100	260 x 250 x 44
25 x 30	26	32	22	100	290 x 280 x 44
25 x 40	26	42	27	100	290 x 280 x 54
30 x 30	31	32	30	100	340 x 330 x 44
30 x 35	31	37	35	100	340 x 330 x 49
30 x 40	31	42	40	100	340 x 330 x 54
35 x 40	36	42	55	50	390 x 198 x 54

ELECTRICAL DATA	
SYMBOL	DESCRIPTION
C _R	rated capacitance at 100 Hz
I _R	rated RMS ripple current at 100 Hz or 10 kHz, 105 °C
I _{L5}	max. leakage current after 5 minutes at U _R
ESR	max. equivalent series resistance at 100 Hz ⁽¹⁾
Z	max. impedance at 10 kHz

Notes

- ⁽¹⁾ ESR at 120 Hz is approximately 0.95 x ESR 100 Hz
- Unless otherwise specified, all electrical values in table 2 apply at T_{amb} = 20 °C, P = 86 kPa to 106 kPa, RH = 45 % to 75 %

ORDERING EXAMPLE

Electrolytic capacitor 090 series
3300 µF/80 V; ± 20 %
Nominal case size: Ø 30 x 40 mm
2-terminal snap-in:
Ordering code: MAL209032332E3
Former 12NC: 222209032332

3-terminal snap-in:
Ordering code: MAL209072332E3
Former 12NC: 222209072332

Table 2

ELECTRICAL DATA AND ORDERING INFORMATION FOR 2 AND 3 TERMINAL SNAP-IN VERSIONS									
U _R (V)	C _R 100 Hz (µF)	NOMINAL CASE SIZE Ø D x L (mm)	I _R 100 Hz 105 °C (A)	I _R 10 kHz 105 °C (A)	I _{L5} 5 min (mA)	MAX. ESR 100 Hz ⁽¹⁾ (mΩ)	MAX. Z 10 kHz (mΩ)	ORDERING CODE MAL2090.....	
								2-TERM. SI	3-TERM. SI
16	6800	22 x 25	2.8	3.3	222	82	66	15682E3	55682E3
	10 000	22 x 30	3.4	4.0	324	59	48	15103E3	55103E3
	15 000	25 x 30	3.6	4.3	484	53	44	25153E3	65153E3
	22 000	25 x 40	4.5	5.5	708	38	33	25223E3	65223E3
	22 000	30 x 30	3.7	4.5	708	54	43	35223E3	75223E3
	27 000	30 x 35	4.2	5.1	868	45	36	35273E3	75273E3
	33 000	30 x 40	4.7	5.6	1060	39	32	35333E3	75333E3
	47 000	35 x 40	4.8	5.8	1508	43	32	45473E3	85473E3
25	4700	22 x 25	2.6	3.1	236	89	66	16472E3	56472E3
	6800	22 x 30	3.2	3.8	341	65	49	16682E3	56682E3
	8200	25 x 30	3.4	4.1	411	60	46	26822E3	66822E3
	10 000	25 x 40	4.3	5.1	501	46	35	26103E3	66103E3
	12 000	25 x 40	4.3	5.2	601	43	34	26123E3	66123E3
	12 000	30 x 30	3.7	4.5	601	56	44	36123E3	76123E3
	15 000	30 x 35	4.2	5.1	751	46	36	16153E3	56153E3
	15 000	30 x 40	4.8	5.7	751	40	33	36153E3	76153E3
22 000	35 x 40	5.1	6.1	1101	40	31	46223E3	86223E3	
35	4700	22 x 30	2.8	3.4	330	78	53	10472E3	50472E3
	6800	25 x 30	3.0	3.6	477	70	50	20682E3	60682E3
	10 000	25 x 40	3.9	4.7	701	49	36	20103E3	60103E3
	10 000	30 x 30	3.2	3.9	701	70	49	30103E3	70103E3
	15 000	30 x 40	4.1	4.9	1051	49	35	30153E3	70153E3
	22 000	35 x 40	4.2	5.0	1541	55	35	40223E3	80223E3

ELECTRICAL DATA AND ORDERING INFORMATION FOR 2 AND 3 TERMINAL SNAP-IN VERSIONS

U _R (V)	C _R 100 Hz (μF)	NOMINAL CASE SIZE Ø D x L (mm)	I _R 100 Hz 105 °C (A)	I _R 10 kHz 105 °C (A)	I _{L5} 5 min (mA)	MAX. ESR 100 Hz ⁽¹⁾ (mΩ)	MAX. Z 10 kHz (mΩ)	ORDERING CODE MAL2090.....	
								2-TERM. SI	3-TERM. SI
40	3300	22 x 25	2.4	2.9	265	99	70	17332E3	57332E3
	3900	22 x 30	2.9	3.4	313	76	54	17392E3	57392E3
	4700	22 x 30	2.9	3.5	377	71	51	17472E3	57472E3
	5600	25 x 30	3.1	3.7	449	69	50	27562E3	67562E3
	6800	25 x 40	3.9	4.7	545	51	38	27682E3	67682E3
	8200	30 x 30	3.3	3.9	657	69	49	37822E3	77822E3
	10 000	30 x 35	3.8	4.5	801	56	41	17103E3	57103E3
	10 000	30 x 40	4.3	5.1	801	48	36	37103E3	77103E3
	15 000	35 x 40	4.5	5.4	1201	50	35	47153E3	87153E3
18 000	35 x 40	4.3	5.1	1441	54	35	47183E3	87183E3	
50	2200	22 x 25	2.1	2.6	221	145	106	11222E3	51222E3
	3300	22 x 30	2.6	3.2	331	101	76	11332E3	51332E3
	3900	25 x 30	2.8	3.4	391	93	71	21392E3	61392E3
	4700	25 x 30	2.9	3.5	471	85	70	31472E3	71472E3
	4700	25 x 40	3.6	4.3	471	71	55	21472E3	61472E3
	5600	25 x 40	3.6	4.4	561	66	51	21562E3	61562E3
	6800	30 x 30	3.1	3.7	681	83	65	31682E3	71682E3
	8200	30 x 35	3.5	4.2	821	68	54	31822E3	71822E3
	10 000	30 x 40	4.0	4.7	1001	58	46	31103E3	71103E3
	15 000	35 x 40	4.0	4.9	1501	63	45	41153E3	81153E3
63	1500	22 x 25	2.1	2.5	190	161	126	18152E3	58152E3
	2200	22 x 30	2.6	3.1	279	114	90	18222E3	58222E3
	2700	25 x 30	2.8	3.4	342	101	81	28272E3	68272E3
	3300	25 x 40	3.5	4.2	417	79	63	28332E3	68332E3
	3900	25 x 40	3.6	4.3	493	71	58	28392E3	68392E3
	3900	30 x 30	3.1	3.8	493	89	74	38392E3	78392E3
	4700	30 x 30	3.1	3.7	594	88	71	18472E3	58472E3
	4700	30 x 35	3.6	4.3	594	74	61	38472E3	78472E3
	5600	30 x 35	3.5	4.2	707	71	59	38562E3	78562E3
	6800	30 x 40	4.0	4.7	858	61	51	38682E3	78682E3
	8200	35 x 40	4.3	5.1	1035	61	50	48822E3	88822E3
80	820	22 x 25	1.5	1.8	133	244	184	12821E3	52821E3
	1000	22 x 30	1.8	2.1	161	196	146	12102E3	52102E3
	1500	25 x 30	2.1	2.6	241	145	113	22152E3	62152E3
	2200	25 x 40	2.8	3.3	353	101	79	22222E3	62222E3
	2200	30 x 30	2.5	3.0	353	119	96	32222E3	72222E3
	2700	30 x 35	2.8	3.4	433	98	79	32272E3	72272E3
	3300	30 x 40	3.2	3.8	529	81	66	32332E3	72332E3
	4700	35 x 40	3.4	4.1	753	75	63	42472E3	82472E3
100	560	22 x 25	1.4	1.6	113	269	184	19561E3	59561E3
	680	22 x 30	1.6	1.9	137	216	146	19681E3	59681E3
	1000	25 x 30	1.9	2.3	201	163	114	29102E3	69102E3
	1500	25 x 40	2.5	3.1	301	111	79	29152E3	69152E3
	1500	30 x 30	2.3	2.7	301	130	98	39152E3	79152E3
	1800	30 x 35	2.6	3.2	361	108	80	39182E3	79182E3
	2200	30 x 40	3.0	3.6	441	90	68	39222E3	79222E3
	3300	35 x 40	3.2	3.8	661	81	64	49332E3	89332E3



ADDITIONAL ELECTRICAL DATA		
PARAMETER	CONDITIONS	VALUE
Voltage		
Surge voltage		$U_s = 1.15 \times U_R$
Reverse voltage		$U_{rev} \leq 1 \text{ V}$
Current		
Leakage current	After 1 minute at U_R	$I_{L1} \leq 0.006 C_R \times U_R + 4 \mu\text{A}$
	After 5 minutes at U_R	$I_{L5} \leq 0.002 C_R \times U_R + 4 \mu\text{A}$
Inductance		
Equivalent series inductance (ESL)	All case sizes	typ. 19 nH
		max. 25 nH

RIPPLE CURRENT AND USEFUL LIFE

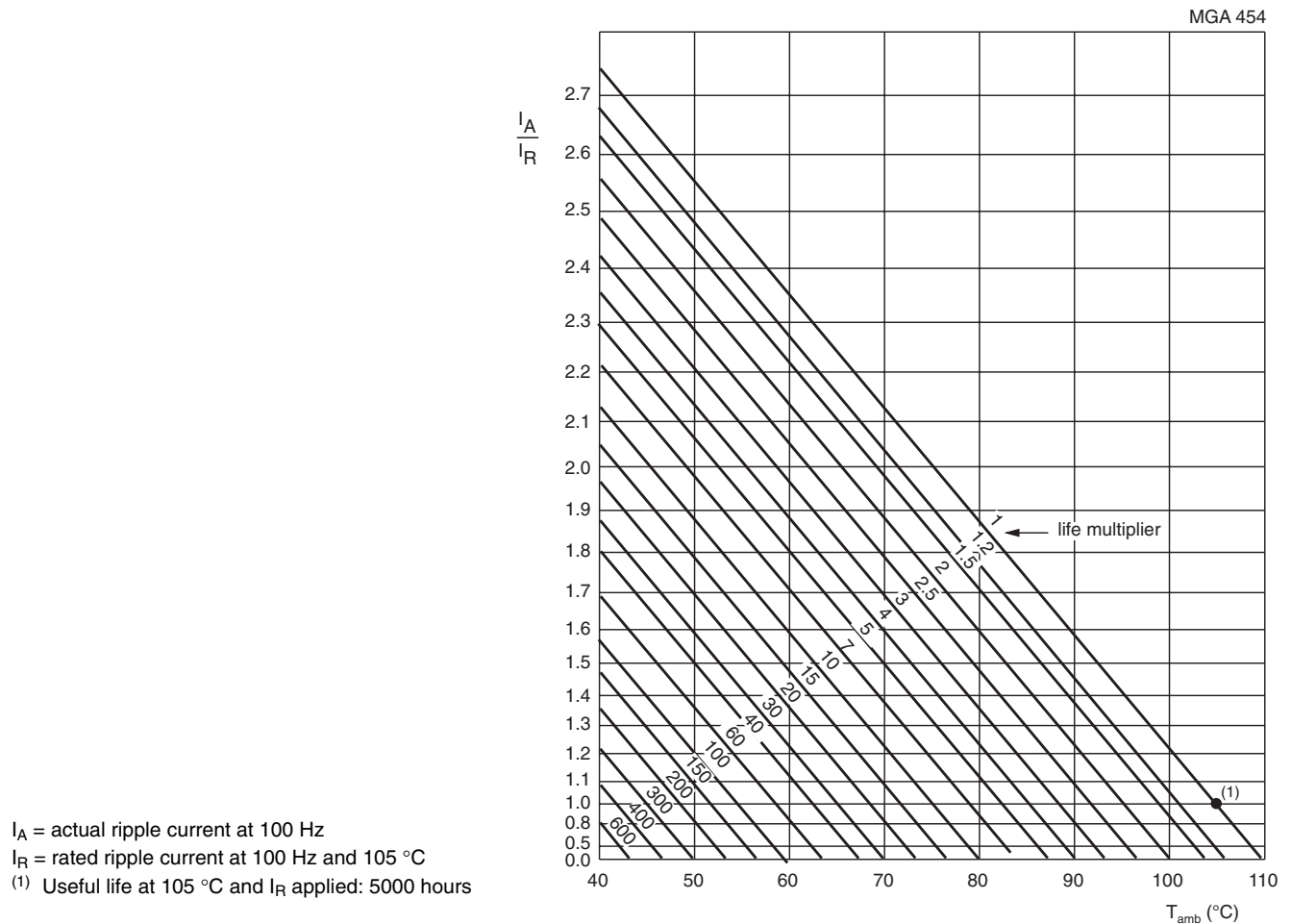


Fig.6 Multiplier of useful life as a function of ambient temperature and ripple current load

Table 3

MULTIPLIER OF RIPPLE CURRENT (I_R) AS A FUNCTION OF FREQUENCY	
FREQUENCY (Hz)	I_R MULTIPLIER
	$U_R = 25 \text{ V to } 100 \text{ V}$
50	0.91
100	1.00
200	1.05
400	1.09
1000	1.13
2000	1.15
4000	1.18
$\geq 10\,000$	1.22

Table 4

TEST PROCEDURES AND REQUIREMENTS			
TEST		PROCEDURE (QUICK REFERENCE)	REQUIREMENTS
NAME OF TEST	REFERENCE		
Endurance	IEC 60384-4/ EN130300 subclause 4.13	$T_{amb} = 105 \text{ }^\circ\text{C}$; U_R applied; 2000 hours	$\Delta C/C: \pm 15 \%$ $ESR \leq 1.3 \times \text{spec. limit}$ $Z \leq 2 \times \text{spec. limit}$ $I_{L5} \leq \text{spec. limit}$
Useful life	CECC 30301 subclause 1.8.1	$T_{amb} = 105 \text{ }^\circ\text{C}$; U_R and I_R applied; 5000 hours	$\Delta C/C: \pm 20 \%$ $ESR \leq 3 \times \text{spec. limit}$ $Z \leq 3 \times \text{spec. limit}$ $I_{L5} \leq \text{spec. limit}$ no short or open circuit, no visible damage total failure percentage: $U_R: \leq 1 \%$
Shelf life (storage at high temperature)	IEC 60384-4/ EN130300 subclause 4.17	$T_{amb} = 105 \text{ }^\circ\text{C}$; no voltage applied; 500 hours after test: U_R to be applied for 30 minutes, 24 hours to 48 hours before measurement	$\Delta C/C: \pm 15 \%$ $ESR \leq 1.5 \times \text{spec. limit}$ $I_{L5} \leq 2 \times \text{spec. limit}$

Aluminum Capacitors Power Ultra Long Life Snap-In

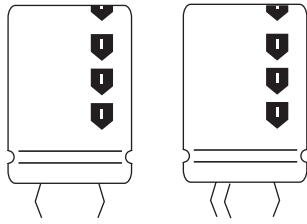


Fig.1 Component outlines



QUICK REFERENCE DATA	
DESCRIPTION	VALUE
Nominal case sizes (Ø D x L in mm)	22 x 25 to 35 x 50
Rated capacitance range (E6/E12 series), C _R	560 µF to 47 000 µF
Tolerance on C _R	± 20 %
Rated voltage range, U _R	16 V to 100 V
Category temperature range	- 40 °C to + 105 °C
Endurance test at 105 °C	2000 hours
Useful life at 105 °C	5000 hours
Useful life at 40 °C, 1.9 x I _R applied	125 000 hours
Shelf life at 0 V, 105 °C	500 hours
Based on sectional specification	IEC 60384-4/EN130300
Climatic category IEC 60068	40/105/56

FEATURES

- Polarized aluminum electrolytic capacitors, non-solid electrolyte
- Large types, very small dimensions, cylindrical aluminum case, insulated with a blue sleeve
- Low ESR, high ripple current capability
- Long useful life: up to 5000 hours at 105 °C
- Keyed polarity version available


**RoHS
COMPLIANT**
APPLICATIONS

- General purpose, industrial telecommunication and audio/video systems
- Smoothing and filtering
- Standard and switched mode power supplies
- Energy storage in pulse systems

MARKING

The capacitors are marked (where possible) with the following information:

- Rated capacitance (in µF)
- Tolerance on rated capacitance, code letter in accordance with IEC 60062 (M for ± 20 %)
- Rated voltage (in V)
- Date code (YYMM)
- Name of manufacturer
- Code for factory of origin
- ‘-’ sign to identify the negative terminal, visible from the top and side of the capacitor
- Code number
- Climatic category in accordance with IEC 60068

SELECTION CHART FOR C _R , U _R AND RELEVANT NOMINAL CASE SIZES (Ø D x L in mm)							
C _R (µF)	U _R (V)						
	16	25	40	50	63	80	100
560	-	-	-	-	-	-	22 x 25
820	-	-	-	-	-	22 x 25	22 x 30
1000	-	-	-	-	-	-	22 x 35
	-	-	-	-	-	-	25 x 30
1200	-	-	-	-	22 x 25	22 x 30	25 x 35
1500	-	-	-	22 x 25	22 x 30	22 x 35	-
	-	-	-	-	-	25 x 30	25 x 40
1800	-	-	-	-	-	25 x 35	-
	-	-	-	-	-	-	30 x 30
2200	-	-	22 x 25	22 x 30	22 x 35	25 x 40	30 x 35
	-	-	-	-	25 x 30	30 x 30	-

SELECTION CHART FOR C_R, U_R AND RELEVANT NOMINAL CASE SIZES (∅ D x L in mm)							
C _R (μF)	U _R (V)						
	16	25	40	50	63	80	100
2700	-	-	-	22 x 35	-	-	30 x 40
	-	-	-	25 x 30	25 x 35	30 x 35	-
3300	-	22 x 25	22 x 30	-	25 x 40	25 x 50	30 x 50
	-	-	-	25 x 35	30 x 30	-	35 x 35
3900	-	-	22 x 35	22 x 45	-	30 x 40	35 x 40
	-	-	25 x 30	25 x 40	30 x 35	-	-
4700	-	22 x 30	22 x 40	-	30 x 40	35 x 35	35 x 50
	-	-	-	30 x 30	-	-	-
5600	22 x 25	-	-	25 x 50	-	35 x 40	-
	-	-	25 x 35	30 x 35	35 x 35	-	-
6800	-	22 x 35	-	30 x 40	30 x 50	35 x 50	-
	-	25 x 30	30 x 30	-	35 x 40	-	-
8200	22 x 30	22 x 40	25 x 50	-	35 x 45	-	-
	-	25 x 35	30 x 35	35 x 35	-	-	-
10 000	22 x 35	25 x 40	30 x 40	35 x 40	35 x 50	-	-
	25 x 30	30 x 30	35 x 30	-	-	-	-
12 000	22 x 40	-	-	35 x 45	-	-	-
	25 x 35	30 x 35	35 x 35	-	-	-	-
15 000	25 x 40	30 x 40	35 x 45	-	-	-	-
18 000	-	-	35 x 50	-	-	-	-
	30 x 35	35 x 35	-	-	-	-	-
22 000	30 x 40	30 x 50	-	-	-	-	-
27 000	-	35 x 45	-	-	-	-	-
	35 x 35	-	-	-	-	-	-
33 000	30 x 50	35 x 50	-	-	-	-	-
	35 x 40	-	-	-	-	-	-
39 000	35 x 45	-	-	-	-	-	-
47 000	35 x 50	-	-	-	-	-	-

DIMENSIONS in millimeters AND AVAILABLE FORMS

TWO TERMINAL SNAP-IN

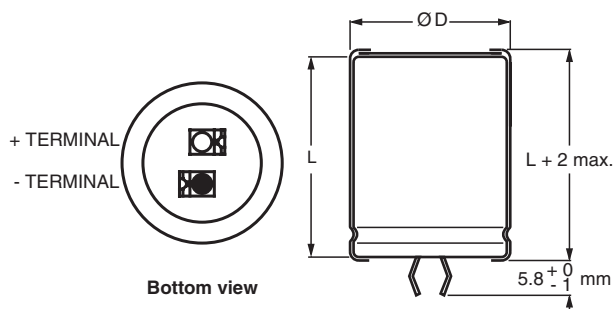


Fig.2 Two terminal snap-in

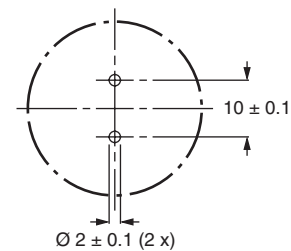
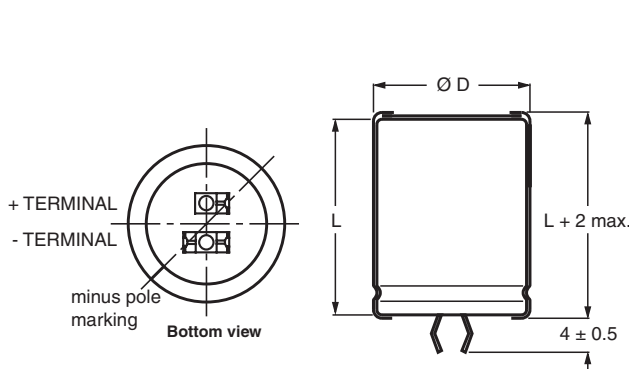


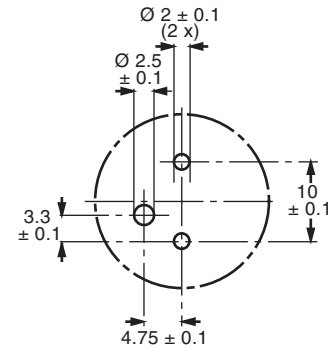
Fig.3 Mounting hole diagram

The minus terminal can be marked with a black dot or with an imprinted '-' sign.

THREE TERMINAL SNAP-IN


The negative terminal has **TWO** pins which are **BOTH** electrically connected.

Fig.4 Three terminal snap-in



The 10 mm spacing of the 2 pin snap-in is used as the base layout and a third hole is added.

The third hole is closer to the negative primary hole so that polarization is always maintained, together with added mechanical stability.

Fig.5 Mounting hole diagram

Table 1

DIMENSIONS in millimeters, MASS AND PACKAGING QUANTITIES					
NOMINAL CASE SIZE Ø D x L	Ø D _{max.}	L _{max.}	MASS (g)	PACKAGING QUANTITIES (units per box)	CARDBOARD BOX DIMENSIONS L x W x H
22 x 25	23	27	≈ 12	100	260 x 250 x 39
22 x 30	23	32	≈ 16	100	260 x 250 x 44
22 x 35	23	37	≈ 20	100	260 x 250 x 49
22 x 40	23	42	≈ 23	100	260 x 250 x 54
25 x 30	26	32	≈ 22	100	290 x 280 x 44
25 x 35	26	37	≈ 24	100	290 x 280 x 49
25 x 40	26	42	≈ 27	100	290 x 280 x 54
25 x 50	26	52	≈ 38	100	290 x 280 x 64
30 x 30	31	32	≈ 30	100	340 x 330 x 44
30 x 35	31	37	≈ 35	100	340 x 330 x 49
30 x 40	31	42	≈ 40	100	340 x 330 x 54
30 x 50	31	52	≈ 50	100	340 x 330 x 64
35 x 35	36	37	≈ 48	50	390 x 198 x 49
35 x 40	36	42	≈ 55	50	390 x 198 x 54
35 x 45	36	47	≈ 63	50	390 x 198 x 59
35 x 50	36	52	≈ 72	50	390 x 198 x 64



ELECTRICAL DATA	
SYMBOL	DESCRIPTION
C_R	rated capacitance at 100 Hz
I_R	rated RMS ripple current at 100 Hz, 105 °C
I_{L5}	max. leakage current after 5 minutes at U_R
ESR	typ./max. equivalent series resistance at 100 Hz ⁽¹⁾
Z	typ./max. impedance at 10 kHz

Note

⁽¹⁾ ESR at 120 Hz is approximately 0.95 x ESR 100 Hz

- Unless otherwise specified, all electrical values in table 2 apply at $T_{amb} = 20\text{ °C}$, $P = 86\text{ kPa}$ to 106 kPa , $RH = 45\%$ to 75%

ORDERING EXAMPLE

Electrolytic capacitor 158 series

3900 $\mu\text{F}/80\text{ V}$; $\pm 20\%$

Nominal case size: $\varnothing 30 \times 40\text{ mm}$

2-terminal snap-in:

Ordering code: MAL2 158 32392 E3

Former 12NC: 2222 158 32392

3-terminal snap-in:

Ordering code: MAL2 158 72392 E3

Former 12NC: 2222 158 72392

Table 2

ELECTRICAL DATA AND ORDERING INFORMATION									
U_R (V)	C_R 100 Hz (μF)	NOMINAL CASE SIZE $\varnothing D \times L$ (mm)	I_R 100 Hz 105 °C (A)	I_R 10 kHz 105 °C (A)	I_{L5} 5 min (mA)	MAX. ESR 100 Hz ⁽¹⁾ (m Ω)	MAX. Z 10 kHz (m Ω)	ORDERING CODE MAL2158.....	
								2-TERM.	3-TERM.
16	5600	22 x 25	2.50	2.95	0.18	111	98	15562E3	55562E3
	8200	22 x 30	3.10	3.66	0.27	79	70	15822E3	55822E3
	10 000	22 x 35	3.56	4.20	0.32	65	58	15103E3	55103E3
	10 000	25 x 30	3.42	4.04	0.32	70	63	25103E3	65103E3
	12 000	22 x 40	4.00	4.72	0.39	56	50	15123E3	55123E3
	12 000	25 x 35	3.91	4.61	0.39	59	53	25123E3	65123E3
	15 000	25 x 40	4.39	5.18	0.48	49	45	25153E3	65153E3
	15 000	30 x 30	3.80	4.48	0.48	61	55	35153E3	75153E3
	18 000	30 x 35	4.36	5.14	0.58	50	46	35183E3	75183E3
	22 000	30 x 40	4.85	5.72	0.71	43	39	35223E3	75223E3
	27 000	35 x 35	4.49	5.30	0.87	49	43	45273E3	85273E3
	33 000	30 x 50	5.70	6.73	1.06	33	31	35333E3	75333E3
	33 000	35 x 40	4.97	5.86	1.06	42	37	45333E3	85333E3
	39 000	35 x 45	5.42	6.40	1.25	37	33	45393E3	85393E3
47 000	35 x 50	5.80	6.84	1.51	33	30	45473E3	85473E3	
25	3300	22 x 25	2.27	2.68	0.17	130	105	16332E3	56332E3
	4700	22 x 30	2.82	3.33	0.24	93	76	16472E3	56472E3
	6800	22 x 35	3.37	3.98	0.34	69	57	16682E3	56682E3
	6800	25 x 30	3.25	3.84	0.34	74	62	26682E3	66682E3
	8200	22 x 40	3.79	4.47	0.41	58	49	16822E3	56822E3
	8200	25 x 35	3.72	4.39	0.41	62	52	26822E3	66822E3
	10 000	25 x 40	4.18	4.93	0.50	52	44	26103E3	66103E3
	10 000	30 x 30	3.65	4.31	0.50	64	55	36103E3	76103E3
	12 000	30 x 35	4.19	4.94	0.60	53	46	36123E3	76123E3
	15 000	30 x 40	4.66	5.50	0.75	45	39	36153E3	76153E3
	18 000	35 x 35	4.36	5.14	0.90	51	43	46183E3	86183E3
	22 000	30 x 50	5.52	6.51	1.10	35	31	36223E3	76223E3
	22 000	35 x 40	4.83	5.70	1.10	44	37	46223E3	86223E3
	27 000	35 x 45	5.24	6.18	1.35	39	33	46273E3	86273E3
33 000	35 x 50	5.32	6.27	1.65	36	31	46333E3	86333E3	



Aluminum Capacitors
Power Ultra Long Life Snap-In

Vishay BCcomponents

ELECTRICAL DATA AND ORDERING INFORMATION									
U _R (V)	C _R 100 Hz (µF)	NOMINAL CASE SIZE Ø D x L (mm)	I _R 100 Hz 105 °C (A)	I _R 10 kHz 105 °C (A)	I _{L5} 5 min (mA)	MAX. ESR 100 Hz ⁽¹⁾ (mΩ)	MAX. Z 10 kHz (mΩ)	ORDERING CODE MAL2158.....	
								2-TERM.	3-TERM.
40	2200	22 x 25	2.17	2.65	0.18	131	100	17222E3	57222E3
	3300	22 x 30	2.73	3.33	0.27	91	70	17332E3	57332E3
	3900	22 x 35	3.12	3.81	0.32	77	59	17392E3	57392E3
	3900	25 x 30	3.02	3.68	0.32	83	65	27392E3	67392E3
	4700	22 x 40	3.52	4.29	0.38	65	51	17472E3	57472E3
	5600	25 x 35	3.53	4.31	0.45	63	51	27562E3	67562E3
	6800	30 x 30	3.39	4.14	0.55	69	56	37682E3	77682E3
	8200	25 x 50	4.72	5.76	0.66	44	36	27822E3	67822E3
	8200	30 x 35	3.90	4.76	0.66	57	47	37822E3	77822E3
	10 000	30 x 40	4.36	5.32	0.80	48	40	37103E3	77103E3
	12 000	35 x 35	4.00	4.88	0.96	56	45	47123E3	87123E3
	15 000	35 x 45	4.99	6.09	1.20	42	35	47153E3	87153E3
	18 000	35 x 50	5.36	6.54	1.44	38	31	47183E3	87183E3
50	1500	22 x 25	1.99	2.43	0.15	148	102	11152E3	51152E3
	2200	22 x 30	2.50	3.05	0.22	104	73	11222E3	51222E3
	2700	22 x 35	2.88	3.51	0.27	85	60	11272E3	51272E3
	2700	25 x 30	2.81	3.43	0.27	91	66	21272E3	61272E3
	3300	22 x 40	3.27	3.99	0.33	71	51	11332E3	51332E3
	3300	25 x 35	3.23	3.94	0.33	75	55	21332E3	61332E3
	3900	25 x 40	3.62	4.42	0.39	64	47	21392E3	61392E3
	4700	30 x 30	3.24	3.95	0.47	74	57	31472E3	71472E3
	5600	25 x 50	4.43	5.40	0.56	48	36	21562E3	61562E3
	5600	30 x 35	3.73	4.55	0.56	61	47	31562E3	71562E3
	6800	30 x 40	4.17	5.09	0.68	52	41	31682E3	71682E3
	8200	35 x 35	3.88	4.73	0.82	61	46	41822E3	81822E3
	10 000	35 x 40	4.33	5.28	1.00	52	40	41103E3	81103E3
12 000	35 x 45	4.72	5.76	1.20	46	35	41123E3	81123E3	
63	1200	22 x 25	2.07	2.53	0.16	137	100	18122E3	58122E3
	1500	22 x 30	2.49	3.04	0.19	107	78	18152E3	58152E3
	2200	22 x 35	3.00	3.66	0.26	79	58	18222E3	58222E3
	2200	25 x 30	2.90	3.54	0.28	85	64	28222E3	68222E3
	2700	25 x 35	3.34	4.07	0.34	70	53	28272E3	68272E3
	3300	25 x 40	3.76	4.59	0.42	59	45	28332E3	68332E3
	3300	30 x 30	3.28	4.00	0.42	74	58	38332E3	78332E3
	3900	30 x 35	3.77	4.60	0.50	61	48	38392E3	78392E3
	4700	30 x 40	4.22	5.15	0.60	52	41	38472E3	78472E3
	5600	35 x 35	3.97	4.84	0.71	59	47	48562E3	88562E3
	6800	30 x 50	5.04	6.15	0.86	40	33	38682E3	78682E3
	6800	35 x 40	4.42	5.39	0.86	51	40	48682E3	88682E3
	8200	35 x 45	4.82	5.88	1.04	45	35	48822E3	88822E3
	10 000	35 x 50	5.17	6.31	1.26	40	32	48102E3	88102E3



ELECTRICAL DATA AND ORDERING INFORMATION									
U _R (V)	C _R 100 Hz (μF)	NOMINAL CASE SIZE Ø D x L (mm)	I _R 100 Hz 105 °C (A)	I _R 10 kHz 105 °C (A)	I _{L5} 5 min (mA)	MAX. ESR 100 Hz ⁽¹⁾ (mΩ)	MAX. Z 10 kHz (mΩ)	ORDERING CODE MAL2158.....	
								2-TERM.	3-TERM.
80	820	22 x 25	1.44	1.76	0.14	422	397	12821E3	52821E3
	1200	22 x 30	1.82	2.22	0.20	291	274	12122E3	52122E3
	1500	22 x 35	2.12	2.59	0.24	234	221	12152E3	52152E3
	1500	25 x 30	2.10	2.56	0.24	240	228	22152E3	62152E3
	1800	25 x 35	2.41	2.94	0.29	201	189	22182E3	62182E3
	2200	25 x 40	2.74	3.34	0.36	166	156	22222E3	62222E3
	2200	30 x 30	2.55	3.11	0.36	180	172	32222E3	72222E3
	2700	30 x 35	2.93	3.57	0.44	147	141	32272E3	72272E3
	3300	25 x 50	3.46	4.22	0.53	114	109	22332E3	62332E3
	3900	30 x 40	3.39	4.14	0.63	110	106	32392E3	72392E3
	4700	35 x 35	3.29	4.01	0.76	110	107	42472E3	82472E3
	5600	35 x 40	3.69	4.50	0.90	93	90	42562E3	82562E3
	6800	35 x 50	4.43	5.40	1.09	75	71	42682E3	82682E3
100	560	22 x 25	1.33	1.62	0.12	461	412	19561E3	59561E3
	820	22 x 30	1.69	2.06	0.17	318	284	19821E3	59821E3
	1000	22 x 35	1.95	2.38	0.20	261	234	19102E3	59102E3
	1000	25 x 30	1.95	2.38	0.20	267	240	29102E3	69102E3
	1200	25 x 35	2.23	2.72	0.24	223	200	29122E3	69122E3
	1500	25 x 40	2.56	3.12	0.30	180	162	29152E3	69152E3
	1800	30 x 30	2.49	3.04	0.36	172	158	39182E3	79182E3
	2200	30 x 35	2.87	3.50	0.44	141	129	39222E3	79222E3
	2700	30 x 40	3.24	3.95	0.54	117	108	39272E3	79272E3
	3300	30 x 50	3.87	4.72	0.66	94	87	39332E3	79332E3
	3300	35 x 35	3.19	3.89	0.66	115	107	49332E3	89332E3
	3900	35 x 40	3.58	4.37	0.78	98	91	49392E3	89392E3
	4700	35 x 50	4.29	5.23	0.94	78	73	49472E3	89472E3

ADDITIONAL ELECTRICAL DATA		
PARAMETER	CONDITIONS	VALUE
Voltage		
Surge voltage		$U_s = 1.15 \times U_R$
Reverse voltage		$U_{rev} \leq 1 \text{ V}$
Current		
Leakage current	After 1 minute at U _R	$I_{L1} \leq 0.006 C_R \times U_R + 4 \mu\text{A}$
	After 5 minutes at U _R	$I_{L5} \leq 0.002 C_R \times U_R + 4 \mu\text{A}$
Inductance		
Equivalent series inductance (ESL)	All case sizes	typ. 19 nH
		max. 25 nH



RIPPLE CURRENT AND USEFUL LIFE

MGA454

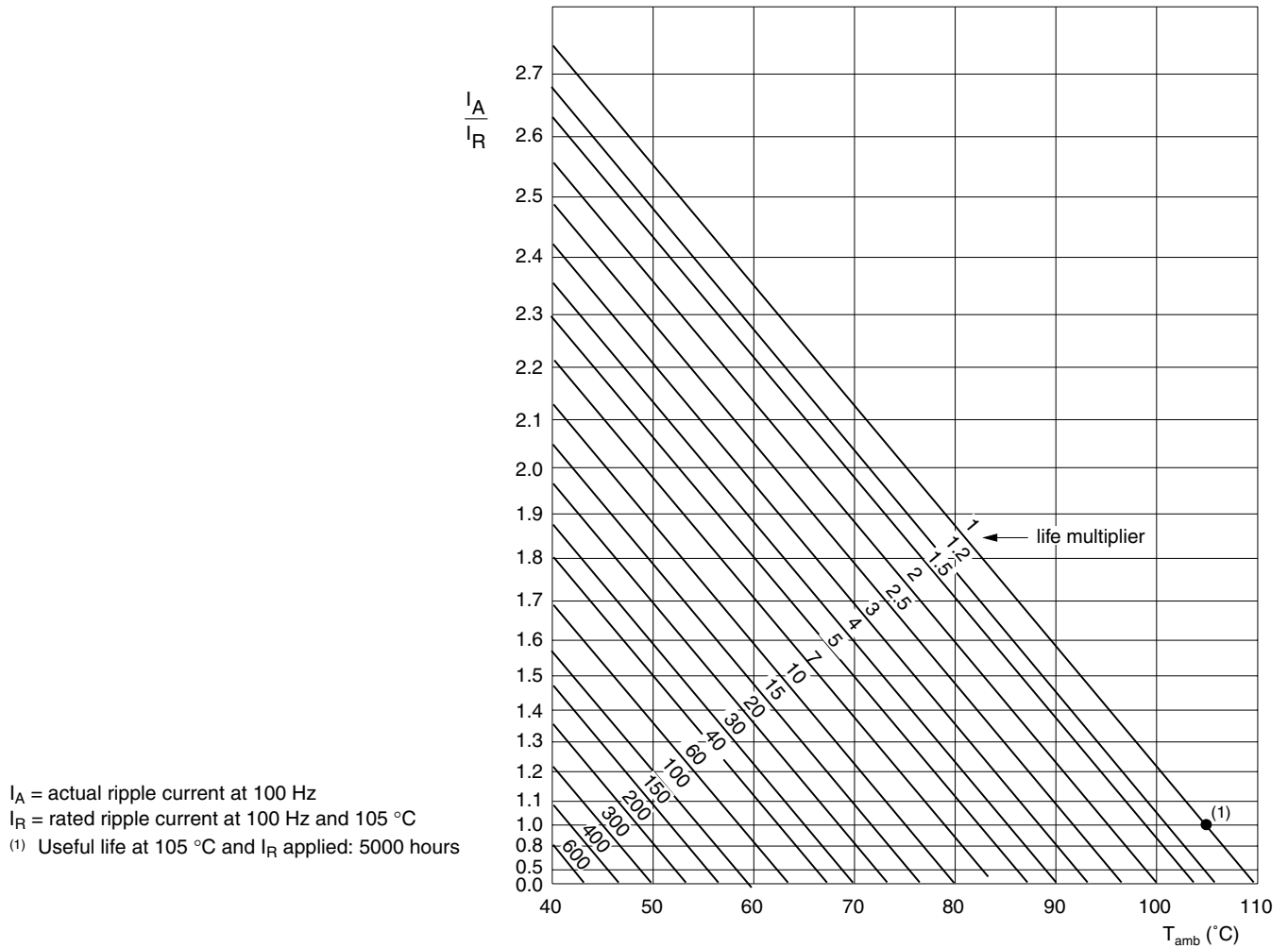


Fig.6 Multiplier of useful life as a function of ambient temperature and ripple current load

Table 3

MULTIPLIER OF RIPPLE CURRENT (I_R) AS A FUNCTION OF FREQUENCY		
FREQUENCY (Hz)	I_R MULTIPLIER	
	$U_R = 16\text{ V to }25\text{ V}$	$U_R = 40\text{ V to }100\text{ V}$
50	0.93	0.91
100	1.00	1.00
200	1.04	1.05
400	1.07	1.09
1000	1.11	1.13
2000	1.13	1.15
4000	1.15	1.18
≥ 10 000	1.18	1.22



Table 4

TEST PROCEDURES AND REQUIREMENTS			
TEST		PROCEDURE (quick reference)	REQUIREMENTS
NAME OF TEST	REFERENCE		
Endurance	IEC 60384-4/ EN130300 subclause 4.13	$T_{amb} = 105\text{ }^{\circ}\text{C}$; U_R applied; 2000 hours	$\Delta C/C: \pm 15\%$ $ESR \leq 1.3 \times \text{spec. limit}$ $Z \leq 2 \times \text{spec. limit}$ $I_{L5} \leq \text{spec. limit}$
Useful life	CECC 30301 subclause 1.8.1	$T_{amb} = 105\text{ }^{\circ}\text{C}$; U_R and I_R applied; 5000 hours	$\Delta C/C: \pm 20\%$ $ESR \leq 3 \times \text{spec. limit}$ $Z \leq 3 \times \text{spec. limit}$ $I_{L5} \leq \text{spec. limit}$ no short or open circuit, no visible damage total failure percentage: $U_R : \leq 1\%$
Shelf life (storage at high temperature)	IEC 60384-4/ EN130300 subclause 4.17	$T_{amb} = 105\text{ }^{\circ}\text{C}$; no voltage applied; 500 hours After test: U_R to be applied for 30 minutes, 24 hours to 48 hours before measurement	$\Delta C/C: \pm 15\%$ $ESR \leq 1.5 \times \text{spec. limit}$ $I_{L5} \leq 2 \times \text{spec. limit}$

Aluminum Capacitors Power Ultra Long Life Snap-In

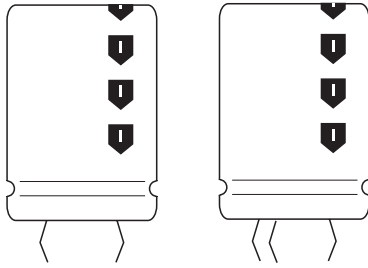


Fig.1 Component outlines



QUICK REFERENCE DATA	
DESCRIPTION	VALUE
Nominal case size (∅ D x L in mm)	22 x 25 to 35 x 60
Rated capacitance range (E6/E12 series), C _R	56 µF to 1800 µF
Tolerance on C _R	± 20 %
Rated voltage range, U _R	200 V, 250 V 400 V, 450 V
Category temperature range	- 25 °C to + 105 °C
Endurance test at 105 °C	2000 hours
Load life at 105 °C	2000 hours
Useful life at 105 °C	5000 hours
Useful life at 40 °C and 1.6 x I _R applied	500 000 hours
Shelf life at 0 V, 105 °C	1000 hours
Based on sectional specification	IEC 60384-4/EN130300
Climatic category IEC 60068	25/105/56

FEATURES

- Polarized aluminum electrolytic capacitors, non-solid electrolyte
- Large types, very small dimensions, cylindrical aluminum case, insulated with a blue sleeve
- Low ESR, high ripple current capability
- Useful life: 5000 hours at 105 °C
- Keyed polarity snap-in version available


**RoHS
COMPLIANT**

APPLICATIONS

- General purpose, industrial and audio/video systems
- Smoothing and filtering
- Standard and switched mode power supplies
- Energy storage in pulse systems

MARKING

The capacitors are marked (where possible) with the following information:

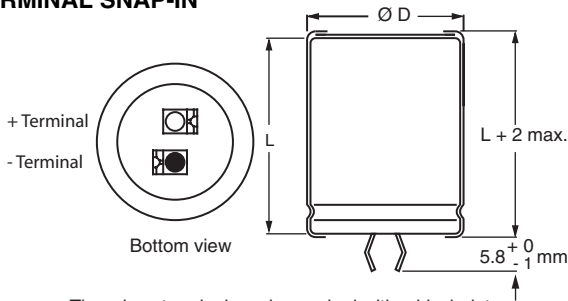
- Rated capacitance (in µF)
- Tolerance code on rated capacitance, code letter in accordance with IEC 60062 (M for ± 20 %)
- Rated voltage (in V)
- Date code (YYMM)
- Name of manufacturer
- Code for factory of origin
- '-' sign to identify the negative terminal, visible from the top and side of the capacitor
- Code number, all 12 or last 8 digits (2222) 159 xxxxx
- Climatic category in accordance with IEC 60068

SELECTION CHART FOR C _R , U _R AND RELEVANT NOMINAL CASE SIZES (∅ D x L in mm)				
C _R (µF)	U _R (V)			
	200	250	400	450
56	-	-	-	22 x 25
68	-	-	22 x 25	22 x 30
	-	-	-	25 x 25
82	-	-	22 x 30	22 x 35
	-	-	25 x 25	-
100	-	-	22 x 35	22 x 40
	-	-	25 x 30	25 x 30
	-	-	-	30 x 25
120	-	-	22 x 35	-
	-	-	25 x 30	25 x 35
	-	-	30 x 25	-
150	-	-	22 x 40	25 x 40
	-	-	25 x 35	30 x 30
	-	-	30 x 30	35 x 25
180	-	-	25 x 40	25 x 45
	-	-	30 x 30	30 x 35
	-	-	35 x 25	-

SELECTION CHART FOR C _R , U _R AND RELEVANT NOMINAL CASE SIZES (∅ D x L in mm)				
C _R (μF)	U _R (V)			
	200	250	400	450
220	-	22 x 30	25 x 45	30 x 40
	-	25 x 25	30 x 35	35 x 30
	-	-	35 x 30	-
270	-	22 x 35	25 x 50	30 x 45
	-	25 x 30	30 x 40	35 x 35
	-	30 x 25	35 x 30	-
330	22 x 30	22 x 40	30 x 45	30 x 50
	-	25 x 30	35 x 35	35 x 40
	-	30 x 25	-	-
390	22 x 35	25 x 35	30 x 50	35 x 45
	25 x 30	30 x 30	35 x 40	-
470	22 x 40	25 x 40	35 x 45	35 x 50
	30 x 25	30 x 30	-	-
	-	35 x 25	-	-
560	-	25 x 45	-	35 x 60
	25 x 35	30 x 35	-	-
	30 x 30	35 x 30	-	-
680	25 x 45	30 x 40	35 x 60	-
	30 x 30	35 x 35	-	-
	35 x 25	-	-	-
820	25 x 50	30 x 45	-	-
	30 x 35	35 x 35	-	-
	35 x 30	35 x 40	-	-
1000	30 x 45	35 x 40	-	-
	35 x 35	35 x 45	-	-
1200	30 x 50	35 x 45	-	-
	35 x 35	35 x 50	-	-
1500	35 x 45	-	-	-
1800	35 x 50	-	-	-

DIMENSIONS in millimeters AND AVAILABLE FORMS

TWO TERMINAL SNAP-IN



The minus terminal can be marked with a black dot or with an imprinted '-' sign.

Fig.2 Two terminal snap-in

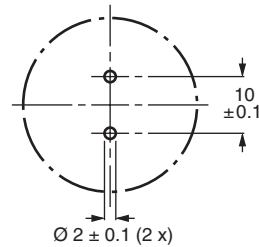
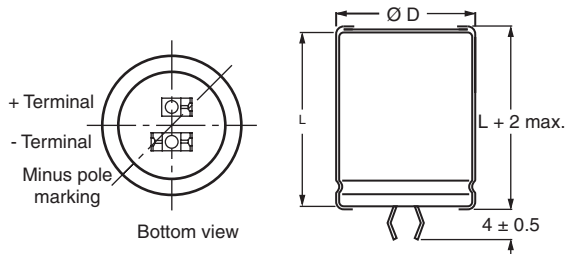


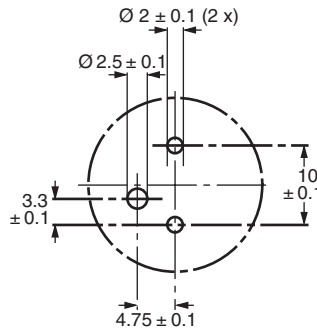
Fig.3 Mounting hole diagram

THREE TERMINAL SNAP-IN



The negative terminal has **TWO** pins which are **BOTH** electrically connected

Fig.4 Two terminal snap-in



The 10 mm spacing of the 2 pin snap-in is used as the base layout and a third hole is added. The third hole is closer to the negative primary hole so that polarization is always maintained, together with added mechanical stability.

Fig.5 Mounting hole diagram



Table 1

DIMENSIONS in millimeters, MASS AND PACKAGING QUANTITIES					
NOMINAL CASE SIZE Ø D x L	Ø D_{max.}	L_{max.}	MASS (g)	PACKAGING QUANTITIES (units per box)	CARDBOARD BOX DIMENSIONS L x W x H
22 x 25	23	27	≈ 12	100	260 x 250 x 39
22 x 30	23	32	≈ 16	100	260 x 250 x 44
22 x 35	23	37	≈ 20	100	260 x 250 x 49
22 x 40	23	42	≈ 23	100	260 x 250 x 54
25 x 25	26	27	≈ 20	100	290 x 280 x 39
25 x 30	26	32	≈ 22	100	290 x 280 x 44
25 x 35	26	37	≈ 24	100	290 x 280 x 49
25 x 40	26	42	≈ 27	100	290 x 280 x 54
25 x 45	26	47	≈ 32	100	290 x 280 x 59
25 x 50	26	52	≈ 38	100	290 x 280 x 64
30 x 25	31	27	≈ 25	100	340 x 330 x 39
30 x 30	31	32	≈ 30	100	340 x 330 x 44
30 x 35	31	37	≈ 35	100	340 x 330 x 49
30 x 40	31	42	≈ 40	100	340 x 330 x 54
30 x 45	31	47	≈ 45	100	340 x 330 x 59
30 x 50	31	52	≈ 50	100	340 x 330 x 64
35 x 25	36	27	≈ 33	50	390 x 198 x 39
35 x 30	36	32	≈ 40	50	390 x 198 x 44
35 x 35	36	37	≈ 48	50	390 x 198 x 49
35 x 40	36	42	≈ 55	50	390 x 198 x 54
35 x 45	36	47	≈ 63	50	390 x 198 x 59
35 x 50	36	52	≈ 72	50	390 x 198 x 64
35 x 60	36	62	≈ 84	50	390 x 198 x 74

ELECTRICAL DATA	
SYMBOL	DESCRIPTION
C_R	rated capacitance at 100 Hz
I_R	rated RMS ripple current at 120 Hz, 105 °C
I_{L5}	max. leakage current after 5 minutes at U _R
ESR	typ./max. equivalent series resistance at 100 Hz ⁽¹⁾
Z	typ./max. impedance at 10 kHz

Notes

- ⁽¹⁾ ESR at 120 Hz is approximately 0.95 x ESR 100 Hz
- Unless otherwise specified, all electrical values in table 2 apply at T_{amb} = 20 °C, P = 86 kPa to 106 kPa, RH = 45 % to 75 %

ORDERING EXAMPLE

Electrolytic capacitor 159 series
1000 µF/200 V; ± 20 %
Nominal case size: Ø 30 x 45 mm
2-terminal snap-in:
Ordering code: MAL2 15942102 E3
Former 12NC: 2222 15942102
3-terminal snap-in:
Ordering code: MAL2 15922102 E3
Former 12NC: 2222 15922102



Table 2

ELECTRICAL DATA AND ORDERING INFORMATION										
U _R (V)	C _R 100 Hz (μF)	NOMINAL CASE SIZE Ø D x L (mm)	I _R 120 Hz 105 °C (A)	I _{L5} 5 min (mA)	TYP. ESR 100 Hz ⁽¹⁾ (mΩ)	MAX. ESR 100 Hz ⁽¹⁾ (mΩ)	TYP. Z 10 kHz (mΩ)	MAX. Z 10 kHz (mΩ)	ORDERING CODE MAL2159.....	
									2-TERM.	3-TERM.
200	330	22 x 30	1.08	0.66	450	730	300	500	52331E3	72331E3
	390	22 x 35	1.23	0.78	380	610	280	470	42391E3	22391E3
	390	25 x 30	1.23	0.78	380	610	280	470	52391E3	72391E3
	470	22 x 40	1.37	0.94	300	505	240	400	32471E3	12471E3
	470	30 x 25	1.27	0.94	300	505	240	400	52471E3	72471E3
	560	25 x 35	1.50	1.12	260	425	235	390	42561E3	22561E3
	560	30 x 30	1.52	1.12	260	425	235	390	52561E3	72561E3
	680	25 x 45	1.82	1.36	210	350	205	340	42681E3	22681E3
	680	30 x 30	1.59	1.36	210	350	205	340	52681E3	72681E3
	680	35 x 25	1.44	1.36	210	350	205	340	62681E3	82681E3
	820	25 x 50	2.04	1.64	180	290	145	240	32821E3	12821E3
	820	30 x 35	1.83	1.64	180	290	145	240	42821E3	22821E3
	820	35 x 30	1.77	1.64	180	290	145	240	52821E3	72821E3
	1000	30 x 45	2.23	2.00	150	235	135	225	42102E3	22102E3
	1000	35 x 35	2.04	2.00	150	235	135	225	52102E3	72102E3
	1200	30 x 50	2.47	2.40	130	210	115	190	42122E3	22122E3
	1200	35 x 35	2.07	2.40	130	210	115	190	52122E3	72122E3
	1500	35 x 45	2.56	3.00	100	170	95	155	52152E3	72152E3
1800	35 x 50	2.80	3.60	90	150	80	130	52182E3	72182E3	
250	220	22 x 30	1.00	0.55	540	1080	420	700	43221E3	23221E3
	220	25 x 25	1.00	0.55	540	1080	420	700	53221E3	73221E3
	270	22 x 35	1.07	0.67	440	880	335	560	43271E3	23271E3
	270	25 x 30	1.08	0.67	440	880	335	560	53271E3	73271E3
	270	30 x 25	1.08	0.67	440	880	335	560	63271E3	83271E3
	330	22 x 40	1.20	0.82	360	720	255	430	33331E3	13331E3
	330	25 x 30	1.21	0.82	360	720	255	430	43331E3	23331E3
	330	30 x 25	1.19	0.82	360	720	255	430	53331E3	73331E3
	390	25 x 35	1.39	0.97	330	610	245	410	43391E3	23391E3
	390	30 x 30	1.41	0.97	330	610	245	410	53391E3	73391E3
	470	25 x 40	1.58	1.17	270	505	240	400	33471E3	13471E3
	470	30 x 30	1.57	1.17	270	505	240	400	43471E3	23471E3
	470	35 x 25	1.37	1.17	270	505	240	400	53471E3	73471E3
	560	25 x 45	1.78	1.40	230	425	185	310	43561E3	23561E3
	560	30 x 35	1.71	1.40	230	425	185	310	53561E3	73561E3
	560	35 x 30	1.67	1.40	230	425	185	310	63561E3	83561E3
	680	30 x 40	1.93	1.70	210	350	155	260	43681E3	23681E3
	680	35 x 35	1.92	1.70	210	350	155	260	53681E3	73681E3
	820	30 x 45	2.16	2.05	180	290	125	210	43821E3	23821E3
	820	35 x 35	1.97	2.05	180	290	125	210	53821E3	73821E3
	820	35 x 40	2.16	2.05	180	290	125	210	63821E3	83821E3
	1000	35 x 40	2.22	2.50	140	235	105	180	53102E3	73102E3
	1000	35 x 45	2.41	2.50	140	235	105	180	63102E3	83102E3
	1200	35 x 45	2.46	3.00	130	200	95	160	43122E3	23122E3
1200	35 x 50	2.65	3.00	130	200	95	160	53122E3	73122E3	

Note⁽¹⁾ ESR at 120 Hz is approximately 0.95 x ESR 100 Hz



ELECTRICAL DATA AND ORDERING INFORMATION										
U _R (V)	C _R 100 Hz (µF)	NOMINAL CASE SIZE Ø D x L (mm)	I _R 120 Hz 105 °C (A)	I _{L5} 5 min (mA)	TYP. ESR 100 Hz ⁽¹⁾ (mΩ)	MAX. ESR 100 Hz ⁽¹⁾ (mΩ)	TYP. Z 10 kHz (mΩ)	MAX. Z 10 kHz (mΩ)	ORDERING CODE MAL2159.....	
									2-TERM.	3-TERM.
400	68	22 x 25	0.51	0.27	1600	3200	1170	1950	56689E3	76689E3
	82	22 x 30	0.60	0.33	1200	2400	910	1520	46829E3	26829E3
	82	25 x 25	0.60	0.33	1200	2400	910	1520	56829E3	76829E3
	100	22 x 35	0.69	0.40	990	1980	740	1240	46101E3	26101E3
	100	25 x 30	0.70	0.40	990	1980	740	1240	56101E3	76101E3
	120	22 x 35	0.76	0.48	800	1600	660	1100	46121E3	26121E3
	120	25 x 30	0.76	0.48	800	1600	660	1100	56121E3	76121E3
	120	30 x 25	0.77	0.48	800	1600	660	1100	66121E3	86121E3
	150	22 x 40	0.86	0.60	700	1400	510	860	36151E3	16151E3
	150	25 x 35	0.89	0.60	700	1400	510	860	46151E3	26151E3
	150	30 x 30	0.92	0.60	700	1400	510	860	56151E3	76151E3
	180	25 x 40	1.01	0.72	590	1170	420	700	36181E3	16181E3
	180	30 x 30	0.99	0.72	590	1170	420	700	46181E3	26181E3
	180	35 x 25	0.96	0.72	590	1170	420	700	56181E3	76181E3
	220	25 x 45	1.15	0.88	470	940	350	590	46221E3	26221E3
	220	30 x 35	1.15	0.88	470	940	350	590	56221E3	76221E3
	220	35 x 30	1.14	0.88	470	940	350	590	66221E3	86221E3
	270	25 x 50	1.31	1.08	380	760	330	550	46271E3	26271E3
	270	30 x 40	1.30	1.08	380	760	330	550	56271E3	76271E3
	270	35 x 30	1.21	1.08	380	760	330	550	66271E3	86271E3
	330	30 x 45	1.47	1.32	320	640	270	450	56331E3	76331E3
	330	35 x 35	1.40	1.32	320	640	270	450	66331E3	86331E3
	390	30 x 50	1.63	1.56	270	540	240	410	46391E3	26391E3
	390	35 x 40	1.57	1.56	270	540	240	410	56391E3	76391E3
470	35 x 45	1.72	1.88	230	450	200	330	56471E3	76471E3	
560	35 x 50	1.84	2.24	210	420	170	280	56561E3	76561E3	
680	35 x 60	2.24	2.72	180	350	130	230	56681E3	76681E3	
450	56	22 x 25	0.48	0.25	1600	3200	1120	1880	57569E3	77569E3
	68	22 x 30	0.56	0.30	1200	2400	910	1530	47689E3	27689E3
	68	25 x 25	0.56	0.30	1200	2400	910	1530	57689E3	77689E3
	82	22 x 35	0.64	0.36	1100	2200	770	1290	57829E3	77829E3
	100	22 x 40	0.74	0.45	900	1800	630	1050	37101E3	17101E3
	100	25 x 30	0.71	0.45	900	1800	630	1050	47101E3	27101E3
	100	30 x 25	0.73	0.45	900	1800	630	1050	57101E3	77101E3
	120	25 x 35	0.82	0.54	750	1500	530	885	57121E3	77121E3
	150	25 x 40	0.95	0.67	600	1200	420	705	47151E3	27151E3
	150	30 x 30	0.93	0.67	600	1200	420	705	57151E3	77151E3
	150	35 x 25	0.91	0.67	600	1200	420	705	67151E3	87151E3
	180	25 x 45	1.07	0.81	500	1000	360	605	47181E3	27181E3
	180	30 x 35	1.06	0.81	500	1000	360	605	57181E3	77181E3
	220	30 x 40	1.21	0.99	370	740	310	525	47221E3	27221E3
	220	35 x 30	1.14	0.99	370	740	310	525	57221E3	77221E3
	270	30 x 45	1.37	1.21	350	700	270	450	47271E3	27271E3
	270	35 x 35	1.32	1.21	350	700	270	450	57271E3	77271E3
	330	30 x 50	1.54	1.48	300	600	230	390	47331E3	27331E3
	330	35 x 40	1.49	1.48	300	600	230	390	57331E3	77331E3
	390	35 x 45	1.61	1.75	250	500	200	340	57391E3	77391E3
	470	35 x 50	1.72	2.11	210	420	170	290	57471E3	77471E3
	560	35 x 60	2.11	2.52	190	380	140	240	57561E3	77561E3

Note

⁽¹⁾ ESR at 120 Hz is approximately 0.95 x ESR 100 Hz



ADDITIONAL ELECTRICAL DATA		
PARAMETER	CONDITIONS	VALUE
Voltage		
Surge voltage	≥ 400 V versions	$U_S = 1.1 \times U_R$
	≤ 250 V versions	$U_S = 1.15 \times U_R$
Reverse voltage		≤ 1 V
Current		
Leakage current	After 5 minutes at U_R	$I_{L5} \leq 0.01 C_R \times U_R$
Inductance		
Equivalent series inductance (ESL)	All case sizes	typ. 19 nH
		max. 25 nH

RIPPLE CURRENT AND USEFUL LIFE

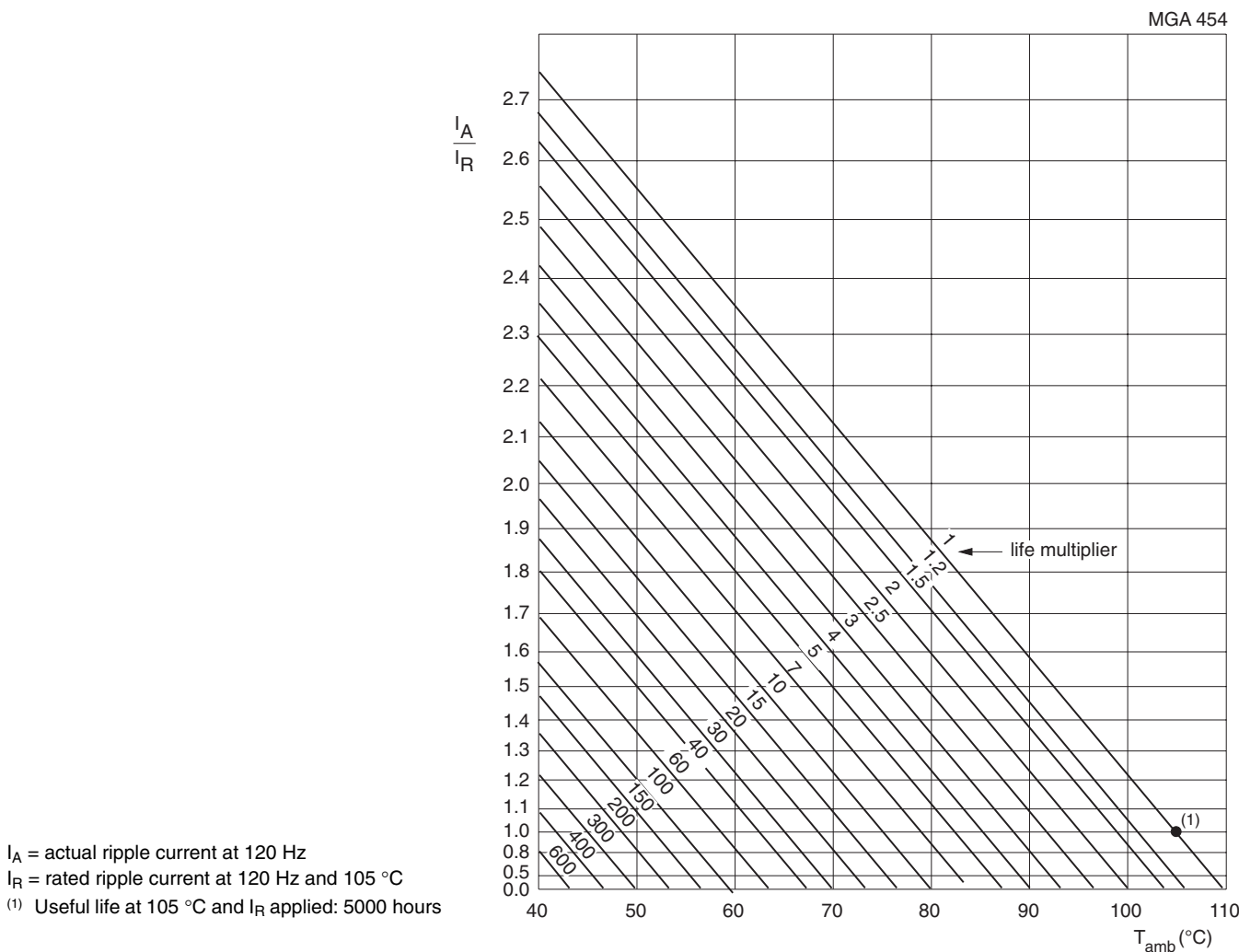


Fig.6 Multiplier of useful life as a function of ambient temperature and ripple current load



Table 3

MULTIPLIER OF RIPPLE CURRENT (I_R) AS A FUNCTION OF FREQUENCY	
FREQUENCY (Hz)	I_R MULTIPLIER
50	0.90
100	0.95
120	1.00
200	1.15
1000	1.30
$\geq 10\ 000$	1.40

Table 4

TEST PROCEDURES AND REQUIREMENTS			
TEST		PROCEDURE (quick reference)	REQUIREMENTS
NAME OF TEST	REFERENCE		
Endurance	IEC 60384-4/ EN130300 subclause 4.13	$T_{amb} = 105\ ^\circ\text{C}$; U_R applied; 2000 h	$\Delta C/C: \pm 15\ \%$ $ESR \leq 1.3 \times \text{spec. limit}$ $I_{L5} \leq \text{spec. limit}$
Load life		$T_{amb} = 105\ ^\circ\text{C}$; U_R and I_R applied; 2000 h	$\Delta C/C: \pm 20\ \%$ $ESR \leq 2 \times \text{spec. limit}$ $I_{L5} \leq \text{spec. limit}$
Useful life	CECC 30301 subclause 1.8.1	$T_{amb} = 105\ ^\circ\text{C}$; U_R and I_R applied; 5000 h	$\Delta C/C: \pm 30\ \%$ $ESR \leq 3 \times \text{spec. limit}$ $I_{L5} \leq \text{spec. limit}$ total failure percentage: $\leq 3\ \%$
Shelf life (storage at high temperature)	IEC 60384-4/ EN130300 subclause 4.17	$T_{amb} = 105\ ^\circ\text{C}$; no voltage applied; 1000 h After test: U_R to be applied for 30 minutes, 24 hours to 48 hours before measurement	$\Delta C/C: \pm 15\ \%$ $ESR \leq 1.5 \times \text{spec. limit}$ $I_{L5} \leq \text{spec. limit}$

Aluminum Capacitors Power Economy Long Life Snap-In

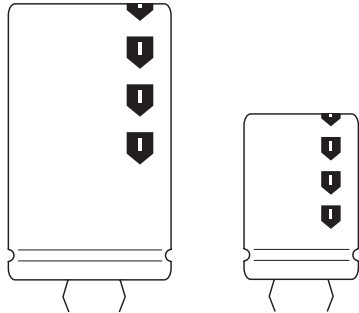


Fig.1 Component outlines

FEATURES

- Polarized aluminum capacitors, non-solid electrolyte
- Large types, very small dimensions, cylindrical aluminum case, insulated with a blue sleeve
- Useful life: 3000 hours at 105 °C



RoHS
COMPLIANT

APPLICATIONS

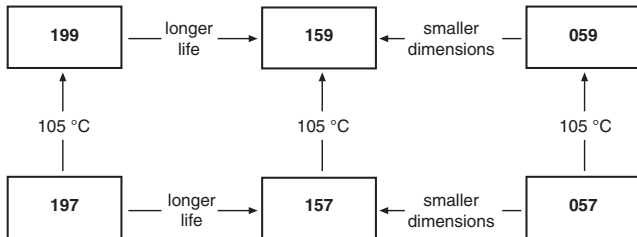
Consumer and industrial electronics:

- Whitegood motor control
- Electronic drives
- Smmps/ups

MARKING

The capacitors are marked (where possible) with the following information:

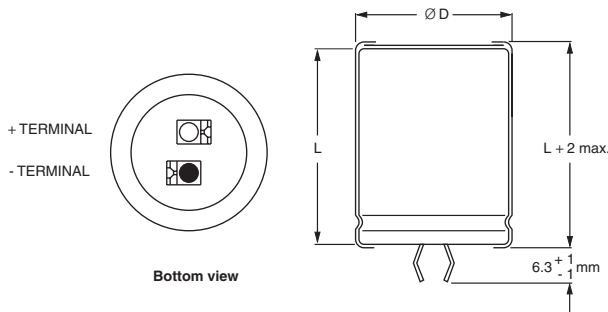
- Rated capacitance (in μF)
- Tolerance code on rated capacitance, code letter in accordance with IEC 60062 (M for $\pm 20\%$)
- Rated voltage (in V)
- Name of manufacturer
- Date code
- '-' sign to identify the negative terminal, visible from the top and side of the capacitor
- Code number (last 8 digits)
- Maximum operating temperature



QUICK REFERENCE DATA	
DESCRIPTION	VALUE
Nominal case size (\varnothing D x L in mm)	22 x 25 to 35 x 50
Rated capacitance range, C_R	47 μF to 2200 μF
Tolerance on C_R	$\pm 20\%$
Rated voltage range, U_R	160 V, 200 V, 250 V, 400 V, 450 V
Category temperature range	- 25 °C to + 105 °C
Endurance test at 105 °C	2000 hours
Useful life at 105 °C	3000 hours
Useful life at 40 °C and 1.6 x I_R applied	300 000 hours
Shelf life at 0 V, 105 °C	500 hours
Based on sectional specification	IEC 60384-4/EN130300/W of JISC5141

SELECTION CHART FOR C_R , U_R AND RELEVANT NOMINAL CASE SIZES (\varnothing D x L in mm)					
C_R (μF)	U_R (V)				
	160	200	250	400	450
47	-	-	-	22 x 25	-
56	-	-	-	22 x 25	22 x 25
68	-	-	-	22 x 25	22 x 30
	-	-	-	-	22 x 25
82	-	-	-	22 x 30	22 x 35
	-	-	-	25 x 25	-
100	-	-	-	22 x 35	22 x 40
	-	-	-	25 x 30	25 x 30
	-	-	-	-	30 x 25
120	-	-	-	22 x 35	25 x 35
	-	-	-	25 x 30	-
	-	-	-	30 x 25	-

SELECTION CHART FOR C_R, U_R AND RELEVANT NOMINAL CASE SIZES (∅ D x L in mm)					
C _R (μF)	U _R (V)				
	160	200	250	400	450
150	-	-	-	22 x 40	-
	-	-	-	25 x 35	25 x 40
	-	-	-	30 x 30	30 x 30
	-	-	-	-	35 x 25
180	-	-	-	25 x 40	-
	-	-	-	30 x 30	30 x 35
	-	-	-	35 x 25	-
220	-	-	22 x 30	-	-
	-	-	25 x 25	-	30 x 40
	-	-	-	30 x 35	35 x 30
	-	-	-	35 x 30	-
270	-	-	22 x 35	25 x 50	30 x 45
	-	-	25 x 30	30 x 40	35 x 35
	-	-	30 x 25	35 x 30	-
330	22 x 25	22 x 35	22 x 40	-	30 x 50
	-	-	25 x 30	30 x 45	35 x 40
	-	-	30 x 25	35 x 35	-
390	22 x 30	22 x 35	-	30 x 50	-
	-	25 x 30	25 x 35	35 x 40	35 x 45
	-	-	30 x 30	-	-
470	22 x 35	-	-	-	35 x 50
	-	30 x 25	25 x 40	35 x 50	-
	-	-	30 x 30	-	-
560	-	-	35 x 25	35 x 45	-
	22 x 40	-	-	-	-
	25 x 30	-	-	-	-
	-	30 x 30	30 x 35	35 x 50	-
680	-	-	35 x 30	-	-
	25 x 35	-	-	-	-
	-	30 x 30	30 x 40	-	-
	-	-	35 x 35	-	-
820	-	35 x 25	-	-	-
	25 x 40	25 x 50	30 x 45	-	-
	30 x 30	30 x 35	35 x 35	-	-
	35 x 25	35 x 30	35 x 40	-	-
1000	30 x 35	30 x 45	-	-	-
	35 x 30	35 x 35	35 x 40	-	-
	-	-	35 x 45	-	-
1200	25 x 50	30 x 50	35 x 45	-	-
	30 x 40	-	35 x 50	-	-
	35 x 30	-	-	-	-
1500	30 x 45	35 x 45	-	-	-
	35 x 35	-	-	-	-
1800	30 x 50	-	-	-	-
	35 x 45	35 x 50	-	-	-
2200	35 x 50	-	-	-	-

DIMENSIONS in millimeters AND AVAILABLE FORMS


The minus terminal can be marked with a black dot or with an imprinted sign

Fig.2 Two terminal snap-in

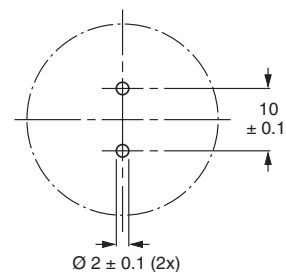


Fig.3 Mounting hole diagram

Table 1

DIMENSIONS in millimeters, MASS AND PACKAGING QUANTITIES					
NOMINAL CASE SIZE Ø D x L	Ø D _{max.}	L _{max.}	MASS (g)	PACKAGING QUANTITIES	CARDBOARD BOX DIMENSIONS L x W x H
22 x 25	22.5	25.5	≈ 12	216	280 x 240 x 140
22 x 30	22.5	30.5	≈ 16	216	280 x 240 x 140
22 x 35	22.5	35.5	≈ 20	144	280 x 240 x 105
22 x 40	22.5	40.5	≈ 23	144	280 x 240 x 105
22 x 45	22.5	45.5	≈ 26	144	280 x 240 x 140
22 x 50	22.5	50.5	≈ 29	72	280 x 240 x 105
25 x 25	25.5	25.5	≈ 20	216	280 x 240 x 140
25 x 30	25.5	32.0	≈ 22	216	280 x 240 x 140
25 x 35	25.5	35.5	≈ 24	144	280 x 240 x 105
25 x 40	25.5	40.5	≈ 27	144	280 x 240 x 105
25 x 45	25.5	45.5	≈ 32	144	280 x 240 x 140
25 x 50	25.5	50.5	≈ 38	144	280 x 240 x 140
30 x 25	30.5	27.5	≈ 25	168	280 x 240 x 140
30 x 30	30.5	32.5	≈ 30	168	280 x 240 x 140
30 x 35	30.5	37.5	≈ 35	112	280 x 240 x 105
30 x 40	30.5	41.5	≈ 40	112	280 x 240 x 105
30 x 45	30.5	46.5	≈ 45	112	280 x 240 x 140
30 x 50	30.5	51.5	≈ 50	112	280 x 240 x 140
35 x 25	35.5	25.5	≈ 33	126	280 x 240 x 140
35 x 30	35.5	32.5	≈ 40	126	280 x 240 x 140
35 x 35	35.5	35.5	≈ 48	84	280 x 240 x 105
35 x 40	35.5	41.5	≈ 55	84	280 x 240 x 105
35 x 45	35.5	46.5	≈ 63	84	280 x 240 x 140
35 x 50	35.5	51.5	≈ 72	84	280 x 240 x 140

ELECTRICAL DATA	
SYMBOL	DESCRIPTION
C _R	rated capacitance at 120 Hz
I _R	rated RMS ripple current at 120 Hz, 105 °C
I _{L5}	max. leakage current after 5 minutes at U _R
ESR	max. equivalent series resistance at 120 Hz ⁽¹⁾

Notes

⁽¹⁾ ESR at 100 Hz is approximately 1.05 x ESR 120 Hz.

- Unless otherwise specified, all electrical values in table 2 apply at T_{amb} = 20 °C, P = 86 kPa to 106 kPa, RH = 45 % to 75 %

ORDERING EXAMPLE

Electrolytic capacitor 199 series

820 µF/160 V; ± 20 %

Nominal case size: Ø 25 x 40 mm

Ordering code: MAL219951821 E3

Former 12NC: 222219951821

Table 2

ELECTRICAL DATA AND ORDERING INFORMATION							
U _R (V)	C _R 120 Hz (µF)	NOMINAL CASE SIZE Ø D x L (mm)	I _R 120 Hz (A)	I _{L5} (mA)	MAX. ESR 120 Hz ⁽¹⁾ (Ω)	MAX. Z 10 kHz (mΩ)	ORDERING CODE MAL2199.....
160	330	22 x 25	1.00	1.06	0.50	316	51331E3
	390	22 x 30	1.17	1.25	0.43	260	51391E3
	470	22 x 35	1.35	1.50	0.35	216	51471E3
	560	22 x 40	1.53	1.50	0.30	183	51561E3
	560	25 x 30	1.42	1.50	0.30	199	41561E3
	680	25 x 35	1.60	1.50	0.24	170	51681E3
	820	25 x 40	1.80	1.50	0.20	144	51821E3
	820	30 x 30	1.67	1.50	0.20	166	41821E3
	820	35 x 25	1.44	1.50	0.30	219	31821E3
	1000	30 x 35	1.86	1.50	0.17	144	41102E3



Aluminum Capacitors
Power Economy Long Life Snap-In

Vishay BCcomponents

ELECTRICAL DATA AND ORDERING INFORMATION							
U_R (V)	C_R 120 Hz (μF)	NOMINAL CASE SIZE Ø D x L (mm)	I_R 120 Hz (A)	I_{L5} (mA)	MAX. ESR 120 Hz ⁽¹⁾ (Ω)	MAX. Z 10 kHz (mΩ)	ORDERING CODE MAL2199.....
160	1000	35 x 30	1.82	1.50	0.25	157	31102E3
	1200	25 x 50	2.24	1.50	0.14	105	51122E3
	1200	30 x 40	2.06	1.50	0.21	124	41122E3
	1200	35 x 30	1.81	1.50	0.21	152	31122E3
	1500	30 x 45	2.30	1.50	0.11	106	51152E3
	1500	35 x 35	1.97	1.50	0.17	134	41152E3
	1800	30 x 50	2.51	1.50	0.09	92	51182E3
	1800	35 x 45	2.45	1.50	0.14	102	41182E3
	2200	35 x 50	2.66	1.50	0.11	90	51222E3
200	330	22 x 35	1.19	1.32	0.50	241	42331E3
	390	22 x 35	1.27	1.50	0.43	212	42391E3
	390	25 x 30	1.27	1.50	0.43	219	52391E3
	470	30 x 25	1.28	1.50	0.35	231	52471E3
	560	30 x 30	1.53	1.50	0.30	180	52561E3
	680	30 x 30	1.57	1.50	0.24	167	52681E3
	680	35 x 25	1.36	1.50	0.37	225	62681E3
	820	25 x 50	2.04	1.50	0.20	115	32821E3
	820	30 x 35	1.75	1.50	0.20	146	42821E3
	820	35 x 30	1.72	1.50	0.30	160	52821E3
	1000	30 x 45	2.14	1.50	0.17	113	42102E3
	1000	35 x 35	1.90	1.50	0.25	140	52102E3
	1200	30 x 50	2.36	1.50	0.14	98	42122E3
	1500	35 x 45	2.31	1.50	0.17	104	52152E3
	1800	35 x 50	2.52	1.50	0.14	92	52182E3
250	220	22 x 30	1.14	1.10	0.75	294	43221E3
	220	25 x 25	0.94	1.10	0.75	317	53221E3
	270	22 x 35	1.11	1.35	0.61	240	43271E3
	270	25 x 30	1.12	1.35	0.61	247	53271E3
	270	30 x 25	1.11	1.35	0.61	274	63271E3
	330	22 x 40	1.27	1.50	0.50	199	33331E3
	330	25 x 30	1.20	1.50	0.50	216	43331E3
	330	30 x 25	1.17	1.50	0.50	250	53331E3
	390	25 x 35	1.35	1.50	0.43	186	43391E3
	390	30 x 30	1.38	1.50	0.43	196	53391E3
	470	25 x 40	1.52	1.50	0.35	158	33471E3
	470	30 x 30	1.43	1.50	0.35	181	43471E3
	470	35 x 25	1.28	1.50	0.53	240	53471E3
	560	30 x 35	1.60	1.50	0.30	158	53561E3
	560	35 x 30	1.59	1.50	0.44	172	63561E3
	680	30 x 40	1.79	1.50	0.24	135	43681E3
	680	35 x 35	1.76	1.50	0.37	150	53682E3
	820	30 x 45	2.00	1.50	0.20	116	43821E3
	820	35 x 35	1.77	1.50	0.30	147	53821E3
	820	35 x 40	1.96	1.50	0.30	130	63821E3
	1000	35 x 40	1.96	1.50	0.25	127	53102E3
	1000	35 x 45	2.17	1.50	0.25	111	63102E3
	1200	35 x 45	2.16	1.50	0.21	110	43122E3
	1200	35 x 50	2.38	1.50	0.21	98	53122E3

**ELECTRICAL DATA AND ORDERING INFORMATION**

U_R (V)	C_R 120 Hz (μ F)	NOMINAL CASE SIZE \varnothing D x L (mm)	I_R 120 Hz (A)	I_{L5} (mA)	MAX. ESR 120 Hz ⁽¹⁾ (Ω)	MAX. Z 10 kHz (m Ω)	ORDERING CODE MAL2199.....
400	47	22 x 25	0.41	0.38	5.29	3127	56479E3
	56	22 x 25	0.45	0.45	4.44	2635	56569E3
	68	22 x 25	0.49	0.54	3.66	2161	56689E3
	82	22 x 30	0.57	0.66	3.03	1788	46829E3
	82	25 x 25	0.58	0.66	3.03	1808	56829E3
	100	22 x 35	0.66	0.80	2.49	1467	46101E3
	100	25 x 30	0.67	0.80	2.49	1472	56101E3
	120	22 x 35	0.72	0.96	2.07	1231	46121E3
	120	25 x 30	0.73	0.96	2.07	1238	56121E3
	120	30 x 25	0.75	0.96	2.07	1266	66121E3
	150	22 x 40	0.84	1.20	1.66	990	36151E3
	150	25 x 35	0.85	1.20	1.66	997	46151E3
	150	30 x 30	0.89	1.20	1.66	1006	56151E3
	180	25 x 40	0.97	1.44	1.38	835	36181E3
	180	30 x 30	0.96	1.44	1.38	854	46181E3
	180	35 x 25	0.94	1.44	1.38	907	56181E3
	220	30 x 35	1.09	1.50	1.13	707	56221E3
	220	35 x 30	1.12	1.50	1.13	719	66221E3
	270	25 x 50	1.25	1.50	0.92	564	46271E3
	270	30 x 40	1.24	1.50	0.92	582	56271E3
	270	35 x 30	1.19	1.50	0.92	611	66271E3
	330	30 x 45	1.41	1.50	0.75	480	56331E3
	330	35 x 35	1.34	1.50	0.75	510	66331E3
	390	30 x 50	1.56	1.50	0.64	410	46391E3
390	35 x 40	1.50	1.50	0.64	435	56391E3	
470	35 x 45	1.68	1.50	0.53	365	56471E3	
470	35 x 50	1.68	1.50	0.53	365	66471E3	
560	35 x 50	1.85	1.50	0.44	311	56561E3	
450	56	22 x 25	0.46	0.50	4.44	2161	57569E3
	68	22 x 30	0.53	0.61	3.66	1776	47689E3
	68	25 x 25	0.54	0.61	3.66	1797	57689E3
	82	22 x 35	0.62	0.74	3.03	1473	57829E3
	100	22 x 40	0.71	0.90	2.49	1211	37101E3
	100	25 x 30	0.69	0.90	2.49	1225	47101E3
	100	30 x 25	0.71	0.90	2.49	1254	57101E3
	120	25 x 35	0.78	1.08	2.07	1025	57121E3
	150	25 x 40	0.91	1.35	1.66	826	47151E3
	150	30 x 30	0.90	1.35	1.66	847	57151E3
	150	35 x 25	0.89	1.35	1.66	902	67151E3
	180	30 x 35	1.02	1.50	1.38	712	57181E3
	220	30 x 40	1.16	1.50	1.13	588	47221E3
	220	35 x 30	1.12	1.50	1.13	618	57221E3
	270	30 x 45	1.31	1.50	0.92	484	47271E3
	270	35 x 35	1.26	1.50	0.75	515	57271E3
	330	30 x 50	1.48	1.50	0.75	402	47331E3
	330	35 x 40	1.42	1.50	1.13	429	57331E3
	390	35 x 45	1.58	1.50	0.64	365	57391E3
	470	35 x 50	1.76	1.50	0.53	309	57471E3

Note

(1) ESR at 100 Hz is approximately 1.05 x ESR 120 Hz



ADDITIONAL ELECTRICAL DATA		
PARAMETER	CONDITIONS	VALUE
Voltage		
Surge voltage	≥ 400 V versions	$U_S = 1.1 \times U_R$
	≤ 250 V versions	$U_S = 1.15 \times U_R$
Reverse voltage	≤ 1 V	-
Current		
Leakage current	After 5 minutes at U_R	$I_{L5} \leq 0.02 C_R \times U_R$ or 1.5 mA, whichever is smaller
Inductance		
Equivalent series inductance (ESL)	All case sizes	19 nH typical/25 nH max.

Table 3

LOW TEMPERATURE CHARACTERISTIC (at 120 Hz)						
DESCRIPTION		U_R (V) ⁽¹⁾				
		160	200	250	400	450
Impedance ratio	$Z(-25\text{ °C})/Z(+20\text{ °C})$	4	4	4	4	4

Note

⁽¹⁾ Impedance ratio shall not exceed the given values

RIPPLE CURRENT AND USEFUL LIFE

I_A = Actual ripple current at 120 Hz
 I_R = Rated ripple current at 120 Hz and 105 °C
⁽¹⁾ Useful life at 105 °C and I_R applied: 3000 hours

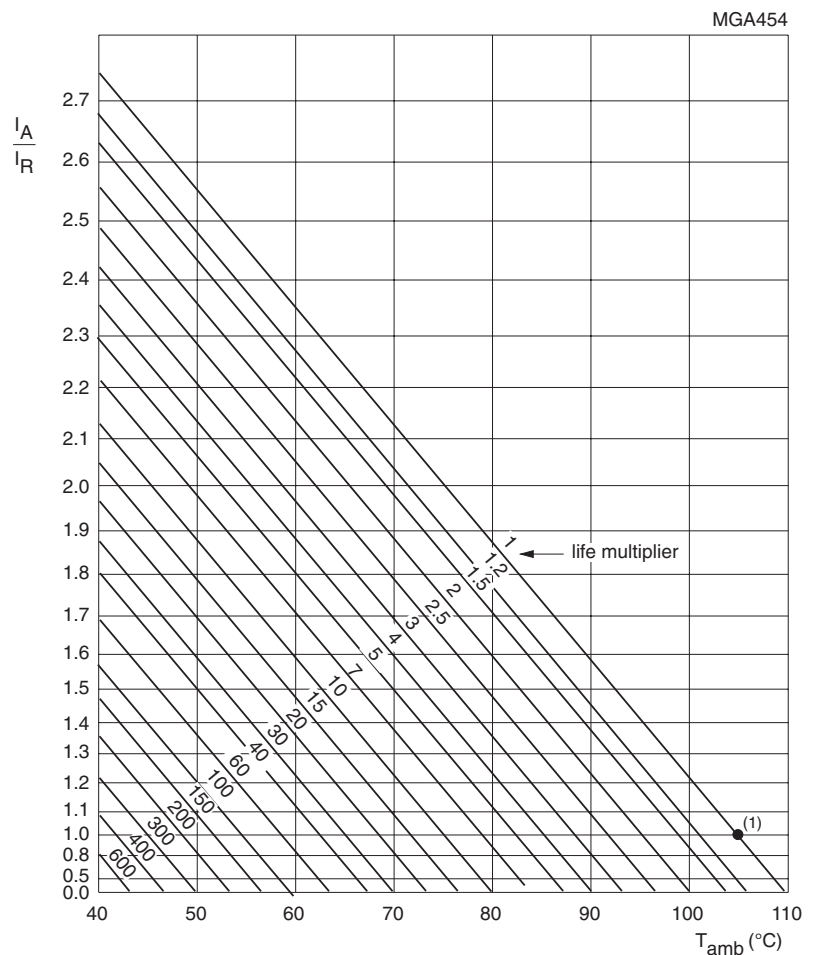


Fig.4 Multiplier of useful life as a function of ambient temperature and ripple current load

Table 4

MULTIPLIER OF RIPPLE CURRENT (I_R) AS A FUNCTION OF FREQUENCY	
FREQUENCY (Hz)	I_R MULTIPLIER
50	0.90
100	0.95
120	1.00
500	1.20
1000	1.30
$\geq 10\ 000$	1.40

Table 5

TEST PROCEDURES AND REQUIREMENTS			
TEST		PROCEDURE (quick reference)	REQUIREMENTS
NAME OF TEST	REFERENCE		
Endurance	IEC 60384-4/ EN130300 subclause 4.13	$T_{amb} = 105\ ^\circ\text{C}$; U_R applied: 2000 hours	DC/C: $\pm 15\ \%$ ESR $\leq 1.3 \times$ spec. limit $I_{L5} \leq$ spec. limit
Useful life	CECC 30301 subclause 1.8.1	$T_{amb} = 105\ ^\circ\text{C}$; U_R and I_R applied: 3000 hours	DC/C: $\pm 30\ \%$ ESR $\leq 3 \times$ spec. limit $I_{L5} \leq$ spec. limit no short or open circuit, no visible damage total failure percentage: $\leq 3\ \%$
Shelf life (storage at high temperature)	IEC 60384-4/ EN130300 subclause 4.17	$T_{amb} = 105\ ^\circ\text{C}$; no voltage applied; 500 hours after test: U_R to be applied for 30 minutes, 24 hours to 48 hours before measurement	DC/C: $\pm 20\ \%$ ESR $\leq 2 \times$ spec. limit $I_{L5} \leq 1 \times$ spec. limit

Aluminum Capacitors Power Long Life Snap-In

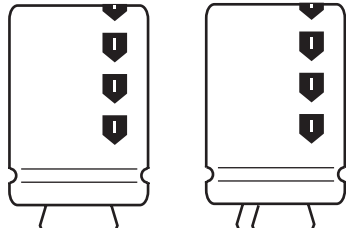
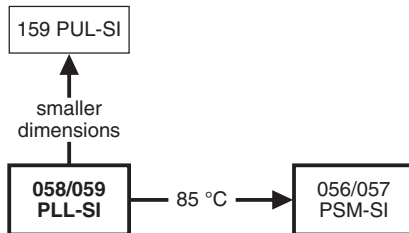


Fig.1 Component outlines


FEATURES

- Polarized aluminum electrolytic capacitors, non-solid electrolyte
- Large types, minimized dimensions, cylindrical aluminum case, insulated with a blue sleeve
- Very long useful life: up to 10 000 hours at 105 °C
- Extended temperature range: 105 °C
- Low ESR, high ripple current capability
- Keyed polarity version available


**RoHS
COMPLIANT**
APPLICATIONS

- Computer, telecommunication and industrial systems
- Smoothing and filtering applications
- Standard and switched mode power supplies
- Energy storage in pulse systems

MARKING

The capacitors are marked (where possible) with the following information:

- Rated capacitance (in μF)
- Tolerance code on rated capacitance, code letter in accordance with IEC 60062 (M for $\pm 20\%$)
- Rated voltage (in V)
- Date code (YYMM)
- Name of manufacturer
- Code for factory of origin
- ‘-’ sign to identify the negative terminal, visible from the top and side of the capacitor
- Code number
- Climatic category in accordance with IEC 60068

QUICK REFERENCE DATA

DESCRIPTION	VALUE	
	058	059
Nominal case sizes ($\varnothing D \times L$ in mm)	22 x 25 to 35 x 50	
Rated capacitance range (E6 series), C_R	33 μF to 47 000 μF	
Tolerance on C_R	$\pm 20\%$	
Rated voltage range, U_R	10 V to 100 V	200 V to 400 V
Category temperature range	-40 °C to 105 °C	-25 °C to 105 °C
Endurance test at 105 °C	≤ 50 V: 2000 hours; ≥ 63 V: 5000 hours	
Useful life at 105 °C	≤ 50 V: 5000 hours; ≥ 63 V: 10 000 hours	
Useful life at 40 °C, 1.9 x I_R applied	≤ 50 V: 125 000 hours; ≥ 63 V: 250 000 hours	
Shelf life at 0 V, 105 °C	500 hours	
Based on sectional specification	IEC 60384-4/EN130300	
Climatic category IEC 60068	40/105/56	25/105/56

SELECTION CHART FOR C_R , U_R AND RELEVANT NOMINAL CASE SIZES FOR 058 SERIES ($\varnothing D \times L$ in mm)

C_R (μF)	U_R (V)						
	10	16	25	40	50	63	100
330	-	-	-	-	-	-	22 x 25
470	-	-	-	-	-	-	22 x 30
680	-	-	-	-	-	22 x 25	25 x 30
	-	-	-	-	-	-	22 x 40
1000	-	-	-	-	22 x 25	22 x 30	30 x 30
	-	-	-	-	-	-	25 x 40
1500	-	-	-	22 x 25	22 x 30	25 x 30	30 x 40
	-	-	-	-	-	22 x 40	25 x 50

SELECTION CHART FOR C_R, U_R AND RELEVANT NOMINAL CASE SIZES FOR 058 SERIES (∅ D x L in mm)

C _R (μF)	U _R (V)						
	10	16	25	40	50	63	100
2200	-	-	22 x 25	22 x 30	25 x 30	30 x 30	35 x 40
	-	-	-	-	22 x 40	25 x 40	30 x 50
3300	-	22 x 25	22 x 30	25 x 30	30 x 30	30 x 40	35 x 50
	-	-	-	22 x 40	25 x 40	25 x 50	-
4700	22 x 25	22 x 30	25 x 30	30 x 30	30 x 40	35 x 40	-
	-	-	22 x 40	25 x 40	25 x 50	30 x 50	-
6800	22 x 30	25 x 30	30 x 30	30 x 40	35 x 40	35 x 50	-
	-	22 x 40	25 x 40	25 x 50	30 x 50	-	-
10 000	25 x 30	30 x 30	30 x 40	35 x 40	35 x 50	-	-
	22 x 40	25 x 40	25 x 50	30 x 50	-	-	-
15 000	30 x 30	30 x 40	35 x 40	35 x 50	-	-	-
	25 x 40	25 x 50	30 x 50	-	-	-	-
22 000	30 x 40	35 x 40	35 x 50	-	-	-	-
	25 x 50	30 x 50	-	-	-	-	-
33 000	35 x 40	35 x 50	-	-	-	-	-
	30 x 50	-	-	-	-	-	-
47 000	35 x 50	-	-	-	-	-	-

SELECTION CHART FOR C_R, U_R AND RELEVANT NOMINAL CASE SIZES FOR 059 SERIES (∅ D x L in mm)

C _R (μF)	U _R (V)			
	200	250	385	400
33	-	-	22 x 25	-
47	-	-	22 x 30	22 x 30
68	-	22 x 25	22 x 35	22 x 35
	-	-	25 x 30	25 x 30
100	22 x 25	22 x 30	30 x 30	30 x 30
	-	-	25 x 40	25 x 40
150	22 x 30	22 x 35	25 x 50	30 x 35
	-	25 x 30	30 x 40	25 x 50
220	22 x 35	30 x 30	35 x 40	35 x 40
	25 x 30	25 x 35	30 x 50	30 x 50
330	30 x 30	30 x 35	35 x 50	35 x 50
	25 x 40	25 x 50	-	-
470	30 x 35	35 x 35	-	-
	25 x 50	30 x 45	-	-
680	35 x 35	35 x 45	-	-
	30 x 45	-	-	-
1000	35 x 50	-	-	-

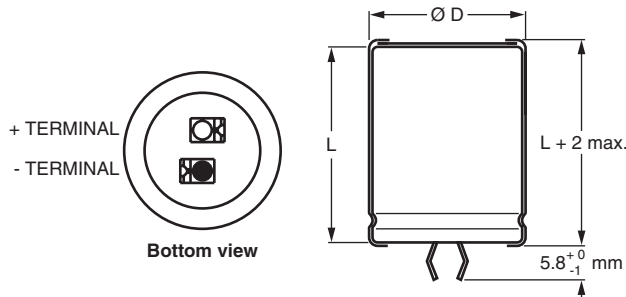
DIMENSIONS in millimeters AND AVAILABLE FORMS
TWO TERMINAL SNAP-IN


Fig.2 Two terminal snap-in

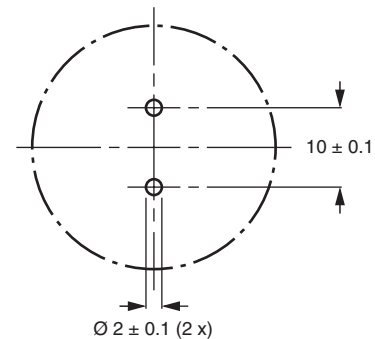


Fig.3 Mounting hole diagram

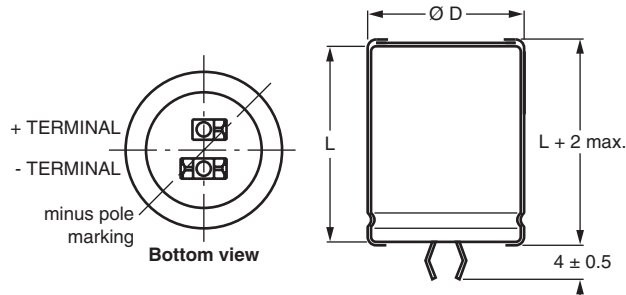
THREE TERMINAL SNAP-IN


Fig.4 Three terminal snap-in

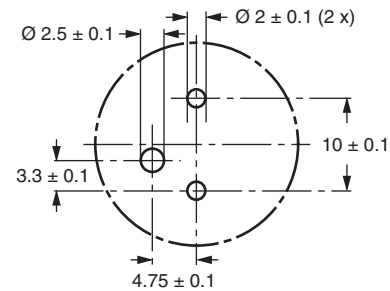


Fig.5 Mounting hole diagram

The minus terminal can be marked with a black dot or with an imprinted '-' sign.

The negative terminal has **TWO** pins which are **BOTH** electrically connected.

The 10 mm spacing of the 2 pin snap-in is used as the base layout and a third hole is added.

The third hole is closer to the negative primary hole so that polarization is always maintained, together with added mechanical stability.

Table 1

DIMENSIONS IN MILLIMETERS, MASS AND PACKAGING QUANTITIES					
NOMINAL CASE SIZE Ø D x L	Ø D _{max.}	L _{max.}	MASS (g)	PACKAGING QUANTITIES (units per box)	CARDBOARD BOX DIMENSIONS L x W x H
22 x 25	23	27	≈ 12	100	260 x 250 x 39
22 x 30	23	32	≈ 16	100	260 x 250 x 44
22 x 35	23	37	≈ 20	100	260 x 250 x 49
22 x 40	23	42	≈ 23	100	260 x 250 x 54
25 x 30	26	32	≈ 22	100	290 x 280 x 44
25 x 35	26	37	≈ 24	100	290 x 280 x 49
25 x 40	26	42	≈ 27	100	290 x 280 x 54
25 x 50	26	52	≈ 38	100	290 x 280 x 64
30 x 30	31	32	≈ 30	100	340 x 330 x 44
30 x 35	31	37	≈ 35	100	340 x 330 x 49
30 x 40	31	42	≈ 40	100	340 x 330 x 54
30 x 45	31	47	≈ 45	100	340 x 330 x 59
30 x 50	31	52	≈ 50	100	340 x 330 x 64
35 x 35	36	37	≈ 48	50	390 x 198 x 49
35 x 40	36	42	≈ 55	50	390 x 198 x 54
35 x 45	36	47	≈ 63	50	390 x 198 x 59
35 x 50	36	52	≈ 72	50	390 x 198 x 64



ELECTRICAL DATA	
SYMBOL	DESCRIPTION
C_R	rated capacitance at 100 Hz
I_R	rated RMS ripple current at 100 Hz or ≥ 10 kHz and 105 °C
I_{L1}	max. leakage current after 1 minute at U_R
I_{L5}	max. leakage current after 5 minutes at U_R
ESR	max. equivalent series resistance at 100 Hz
Z	max. impedance at 10 kHz

Note

- Unless otherwise specified, all electrical values in tables 2 and 3 apply at $T_{amb} = 20$ °C, $P = 86$ kPa to 106 kPa, RH = 45 % to 75 %

Table 2

ELECTRICAL DATA AND ORDERING INFORMATION FOR 058 SERIES (\varnothing D x L in mm)										
U_R (V)	C_R 100 Hz (μ F)	NOMINAL CASE SIZE \varnothing D x L (mm)	I_R 100 Hz 105 °C (A)	I_R ≥ 10 kHz 105 °C (A)	I_{L1} 1 min (μ A)	I_{L5} 5 min (μ A)	ESR 100 Hz (m Ω)	Z 10 Hz (m Ω)	ORDERING CODE MAL2058.....	
									2-TERM.	3-TERM.
10	4700	22 x 25	1.95	2.30	286	98	82	57	54472E3	74472E3
	6800	22 x 30	2.44	2.88	412	140	61	44	54682E3	74682E3
	10 000	25 x 30	2.81	3.32	604	204	54	42	54103E3	74103E3
	10 000	22 x 40	3.29	3.88	604	204	43	32	44103E3	24103E3
	15 000	30 x 30	3.53	4.17	904	304	42	34	54153E3	74153E3
	15 000	25 x 40	3.78	4.46	904	304	38	30	44153E3	24153E3
	22 000	30 x 40	4.62	5.45	1324	444	31	25	54223E3	74223E3
	22 000	25 x 50	4.68	5.52	1324	444	31	24	44223E3	24223E3
	33 000	35 x 40	5.15	6.08	1984	664	30	24	54333E3	74333E3
	33 000	30 x 50	5.70	6.73	1984	664	24	21	44333E3	24333E3
47 000	35 x 50	6.23	7.35	2824	944	24	21	54473E3	74473E3	
16	3300	22 x 25	1.90	2.24	321	110	86	57	55332E3	75332E3
	4700	22 x 30	2.36	2.78	455	154	65	44	55472E3	75472E3
	6800	25 x 30	2.75	3.25	657	222	56	42	55682E3	75682E3
	6800	22 x 40	3.18	3.75	657	222	46	32	45682E3	25682E3
	10 000	30 x 30	3.44	4.06	964	324	44	34	55103E3	75103E3
	10 000	25 x 40	3.66	4.32	964	324	40	30	45103E3	25103E3
	15 000	30 x 40	4.55	5.37	1444	484	32	25	55153E3	75153E3
	15 000	25 x 50	4.55	5.37	1444	484	32	24	45153E3	25153E3
	22 000	35 x 40	5.07	5.98	2116	708	31	24	55223E3	75223E3
	22 000	30 x 50	5.67	6.69	2116	708	25	21	45223E3	25223E3
33 000	35 x 50	6.23	7.35	3172	1060	25	21	55333E3	75333E3	
25	2200	22 x 25	1.76	2.08	334	114	100	57	56222E3	76222E3
	3300	22 x 30	2.23	2.63	499	169	73	44	56332E3	76332E3
	4700	25 x 30	2.60	3.07	709	239	62	42	56472E3	76472E3
	4700	22 x 40	3.00	3.54	709	239	52	32	46472E3	26472E3
	6800	30 x 30	3.26	3.85	1024	344	49	34	56682E3	76682E3
	6800	25 x 40	3.49	4.12	1024	344	44	30	46682E3	26682E3
	10 000	30 x 40	4.37	5.16	1504	504	35	25	56103E3	76103E3
	10 000	25 x 50	4.37	5.16	1504	504	35	24	46103E3	26103E3
	15 000	35 x 40	4.91	5.79	2254	754	33	24	56153E3	76153E3
	15 000	30 x 50	5.43	6.41	2254	754	27	21	46153E3	26153E3
22 000	35 x 50	6.07	7.16	3304	1104	27	21	56223E3	76223E3	
40	1500	22 x 25	1.65	2.01	364	124	114	65	57152E3	77152E3
	2200	22 x 30	2.04	2.49	532	180	87	50	57222E3	77222E3
	3300	25 x 30	2.43	2.99	796	268	71	45	57332E3	77332E3
	3300	22 x 40	2.78	3.39	796	268	60	37	47332E3	27332E3
	4700	30 x 30	2.96	3.61	1132	380	59	40	57472E3	77472E3
	4700	25 x 40	3.26	3.90	1132	380	51	32	47472E3	27472E3
	6800	30 x 40	3.94	4.81	1636	548	42	29	57682E3	77682E3
	6800	25 x 50	4.10	5.00	1636	548	39	26	47682E3	27682E3
	10 000	35 x 40	4.18	5.10	2404	804	46	29	57103E3	77103E3
	10 000	30 x 50	4.98	6.08	2404	804	36	24	47103E3	27103E3
15 000	35 x 50	5.21	6.36	3604	1204	36	24	57153E3	77153E3	

ORDERING EXAMPLE

Electrolytic capacitor 058 series

10 000 μ F/25 V; ± 20 %Nominal case size: $\varnothing 30$ x 40 mm

2-terminal snap-in

Ordering code: MAL205856103E3

Former 12NC: 222205856103

3-terminal snap-in

Ordering code: MAL205876103E3

Former 12NC: 222205876103



ELECTRICAL DATA AND ORDERING INFORMATION FOR 058 SERIES (Ø D x L in mm)										
U _R (V)	C _R 100 Hz (µF)	NOMINAL CASE SIZE Ø D x L (mm)	I _R 100 Hz 105 °C (A)	I _R ≥ 10 kHz 105 °C (A)	I _{L1} 1 min (µA)	I _{L5} 5 min (µA)	ESR 100 Hz (mΩ)	Z 10 Hz (mΩ)	ORDERING CODE MAL2058.....	
									2-TERM.	3-TERM.
50	1000	22 x 25	1.50	1.83	304	104	138	69	51102E3	71102E3
	1500	22 x 30	1.88	2.29	454	154	102	54	51152E3	71152E3
	2200	25 x 30	2.27	2.77	664	124	82	47	51222E3	71222E3
	2200	22 x 40	2.55	3.11	664	124	71	38	41222E3	21222E3
	3300	30 x 30	2.81	3.43	994	334	66	41	51332E3	71332E3
	3300	25 x 40	3.07	3.75	994	334	57	33	41332E3	21332E3
	4700	30 x 40	3.77	4.60	1414	474	47	30	51472E3	71472E3
	4700	25 x 50	3.85	4.70	1414	474	43	27	41472E3	21472E3
	6800	35 x 40	4.01	4.89	2044	684	49	30	51682E3	71682E3
	6800	30 x 50	4.74	5.78	2044	684	38	24	41682E3	21682E3
10000	35 x 50	5.04	6.15	3004	1004	38	24	51103E3	71103E3	
63	680	22 x 25	1.17	1.43	261	90	228	150	58681E3	78681E3
	1000	22 x 30	1.46	1.78	382	130	170	115	58102E3	78102E3
	1500	25 x 30	1.76	2.15	571	193	137	85	58152E3	78152E3
	1500	22 x 40	2.00	2.44	571	193	115	85	48152E3	28152E3
	2200	30 x 30	2.27	2.77	836	281	101	70	58222E3	78222E3
	2200	25 x 40	2.40	2.93	836	281	94	70	48222E3	28222E3
	3300	30 x 40	3.07	3.75	1251	420	70	50	58332E3	78332E3
	3300	25 x 50	3.07	3.75	1251	420	70	50	48332E3	28332E3
	4700	35 x 40	3.65	4.45	1781	596	60	45	58472E3	78472E3
	4700	30 x 50	3.88	4.73	1781	596	53	45	48472E3	28472E3
6800	35 x 50	4.58	5.59	2574	861	46	35	58682E3	78682E3	
100	330	22 x 25	0.92	1.12	202	70	370	250	59331E3	79331E3
	470	22 x 30	1.14	1.39	286	98	280	190	59471E3	79471E3
	680	25 x 30	1.35	1.65	412	140	232	140	59681E3	79681E3
	680	22 x 40	1.57	1.92	412	140	190	140	49681E3	29681E3
	1000	30 x 30	1.79	2.40	604	204	163	115	59102E3	79102E3
	1000	25 x 40	1.85	2.26	604	204	158	115	49102E3	29102E3
	1500	30 x 40	2.45	2.99	904	304	111	85	59152E3	79152E3
	1500	25 x 50	2.38	2.90	904	304	116	85	49152E3	29152E3
	2200	35 x 40	3.05	3.72	1324	444	86	65	59222E3	79222E3
	2200	30 x 50	3.13	3.82	1324	444	82	65	49222E3	29222E3
3300	35 x 50	3.84	4.68	1984	664	64	50	59332E3	79332E3	

Table 3

ELECTRICAL DATA AND ORDERING INFORMATION FOR 059 SERIES										
U _R (V)	C _R 100 Hz (µF)	NOMINAL CASE SIZE Ø D x L (mm)	I _R 100 Hz 105 °C (A)	I _{L1} 1 min (µA)	I _{L5} 5 min (µA)	ESR 100 kHz (µΩ)	Z 10 kHz (mΩ)	ORDERING CODE MAL2059.....		
								2-TERM.	3-TERM.	
200	100	22 x 25	0.53	124	44	1280	730	52101E3	72101E3	
	150	22 x 30	0.67	184	64	850	540	52151E3	72151E3	
	220	22 x 35	0.86	268	92	610	430	32221E3	12221E3	
	220	25 x 30	0.87	268	92	610	430	52221E3	72221E3	
	330	30 x 30	1.12	400	136	435	300	52331E3	72331E3	
	330	25 x 40	1.12	400	136	435	300	42331E3	22331E3	
	470	30 x 35	1.46	568	192	335	225	32471E3	12471E3	
	470	25 x 50	1.25	568	192	335	225	42471E3	22471E3	
	680	30 x 45	1.87	820	276	235	155	32681E3	12681E3	
	680	35 x 35	1.85	820	276	235	155	62681E3	82681E3	
1000	35 x 50	2.45	1204	404	160	125	52102E3	72102E3		
250	68	22 x 25	0.49	106	38	1640	760	53689E3	73689E3	
	100	22 x 30	0.62	154	54	1110	570	53101E3	73101E3	
	150	22 x 35	0.82	229	79	795	440	33151E3	13151E3	
	150	25 x 30	0.82	229	79	795	440	53151E3	73151E3	
	220	25 x 35	1.03	334	114	540	300	33221E3	13221E3	
	220	30 x 30	1.06	334	114	540	300	53221E3	73221E3	
	330	30 x 35	1.43	499	169	385	225	33331E3	13331E3	
	330	25 x 50	1.40	499	169	385	225	43331E3	23331E3	
	470	30 x 45	1.79	709	239	270	155	33471E3	13471E3	
	470	35 x 35	1.79	709	239	270	155	63471E3	83471E3	
680	35 x 45	2.25	1024	344	190	125	43681E3	23681E3		



ELECTRICAL DATA AND ORDERING INFORMATION FOR 059 SERIES									
U _R (V)	C _R 100 Hz (μF)	NOMINAL CASE SIZE Ø D x L (mm)	I _R 100 Hz 105 °C (A)	I _{L1} 1 min (μA)	I _{L5} 5 min (μA)	ESR 100 kHz (μΩ)	Z 10 kHz (mΩ)	ORDERING CODE MAL2059.....	
								2-TERM.	3-TERM.
385	33	22 x 25	0.32	80	29	3860	3000	58339E3	78339E3
	47	22 x 30	0.41	113	40	2710	2100	58479E3	78479E3
	68	22 x 35	0.53	161	56	1870	1460	38689E3	18689E3
	68	25 x 30	0.52	161	56	1870	1460	58689E3	78689E3
	100	30 x 30	0.72	235	81	1270	1010	58101E3	78101E3
	100	25 x 40	0.72	235	81	1270	1010	48101E3	28101E3
	150	30 x 40	0.99	351	119	850	675	58151E3	78151E3
	150	25 x 50	0.99	351	119	850	675	48151E3	28151E3
	220	35 x 40	1.31	512	173	580	465	58221E3	78221E3
	220	30 x 50	1.31	512	173	580	465	48221E3	28221E3
	330	35 x 50	1.75	766	258	390	320	58331E3	78331E3
400	47	22 x 30	0.30	117	42	4260	3490	56479E3	76479E3
	68	22 x 35	0.38	167	58	2950	2420	36689E3	16689E3
	68	25 x 30	0.41	167	58	2950	2420	56689E3	76689E3
	100	30 x 30	0.55	244	84	2020	1660	56101E3	76101E3
	100	25 x 40	0.55	244	84	2020	1660	46101E3	26101E3
	150	30 x 35	0.68	364	124	1350	1110	36151E3	16151E3
	150	25 x 50	0.78	364	124	1350	1110	46151E3	26151E3
	220	35 x 40	0.94	532	180	930	760	56221E3	76221E3
	220	30 x 50	0.94	532	180	930	760	46221E3	26221E3
		330	35 x 50	1.25	796	260	620	510	56331E3

ADDITIONAL ELECTRICAL DATA		
PARAMETER	CONDITIONS	VALUE
Voltage		
Surge voltage	≤ 250 V versions	U _s = 1.15 x U _R
	≥ 385 V versions	U _s = 1.1 x U _R
Reverse voltage		U _{rev} ≤ 1 V
Current		
Leakage current	After 1 minute at U _R	I _{L1} ≤ 0.006 C _R x U _R + 4 μA
	After 5 minutes at U _R	I _{L5} ≤ 0.002 C _R x U _R + 4 μA
Inductance		
Equivalent series inductance (ESL)	All case sizes	typ. 19 nH
		max. 25 nH

CAPACITANCE (C)

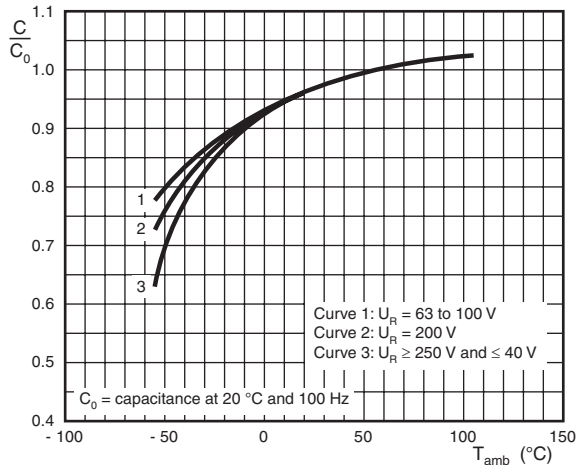


Fig.6 Typical multiplier of capacitance as a function of ambient temperature

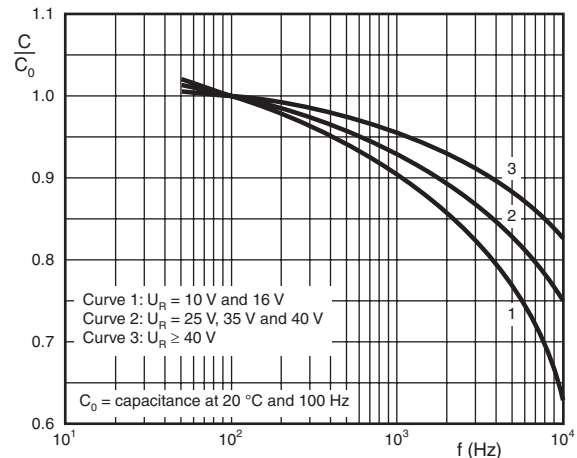


Fig.7 Typical multiplier of capacitance as a function of frequency

EQUIVALENT SERIES RESISTANCE (ESR)

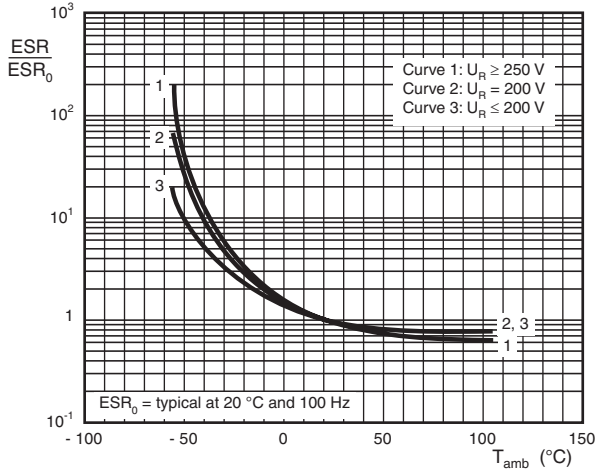


Fig.8 Typical multiplier of ESR as a function of ambient temperature

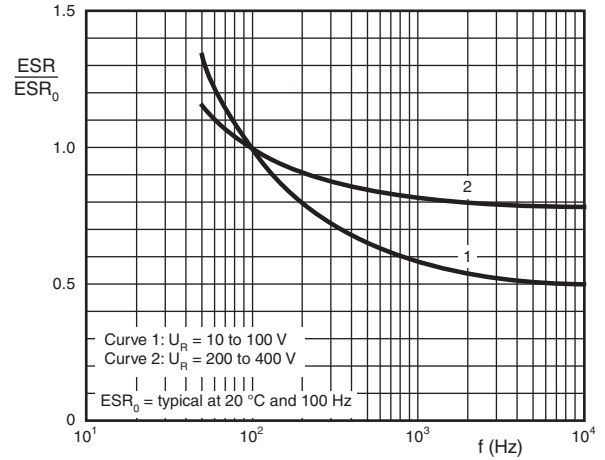


Fig.9 Typical multiplier of ESR as a function of frequency

IMPEDANCE (Z)

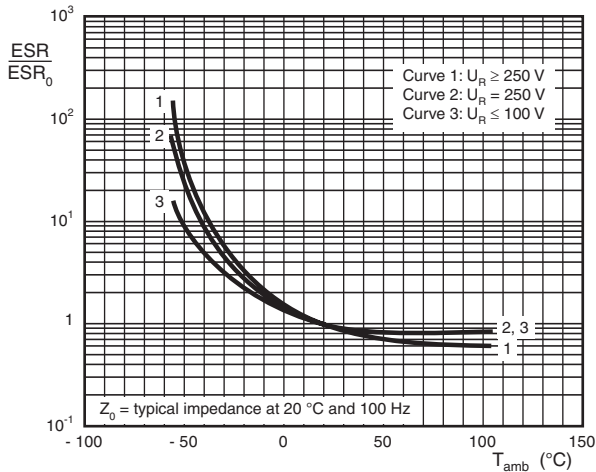


Fig.10 Typical multiplier of impedance as a function of ambient temperature

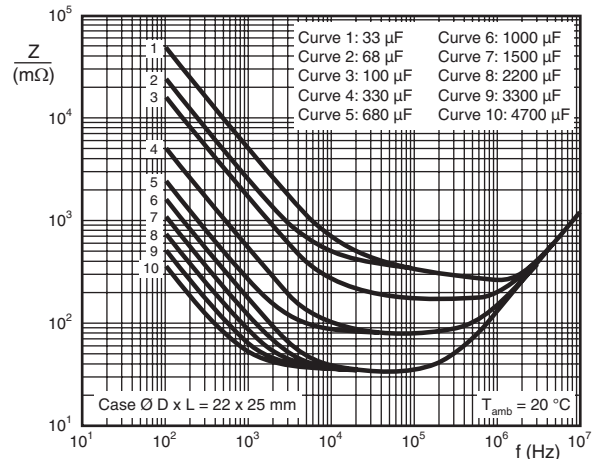


Fig.11 Typical impedance as a function of frequency

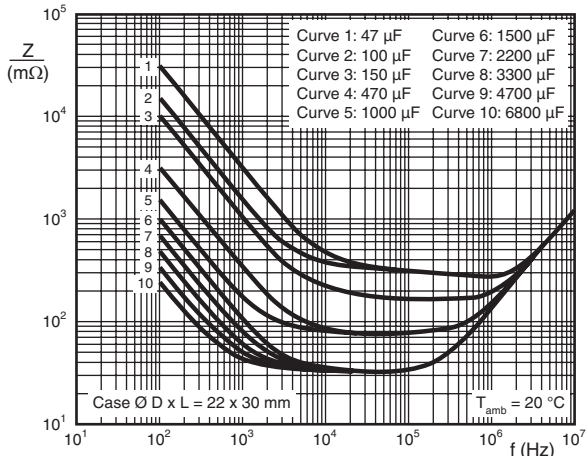


Fig.12 Typical impedance as a function of frequency

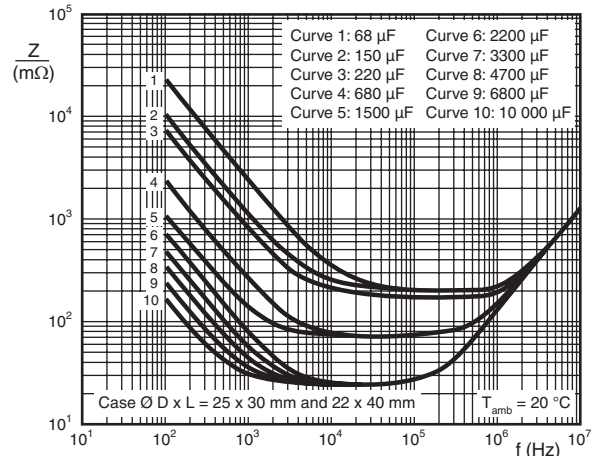


Fig.13 Typical impedance as a function of frequency



IMPEDANCE (Z)

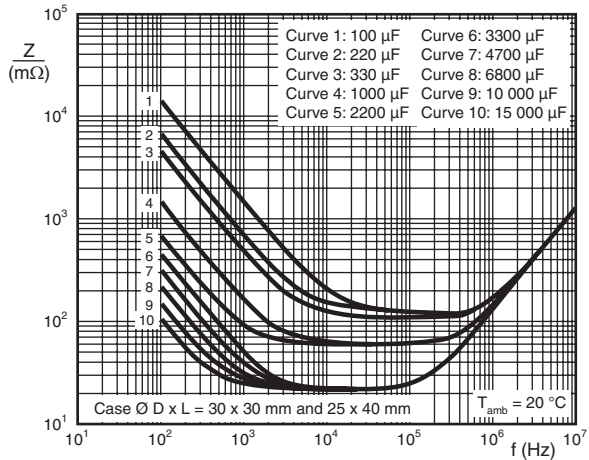


Fig.14 Typical impedance as a function of frequency

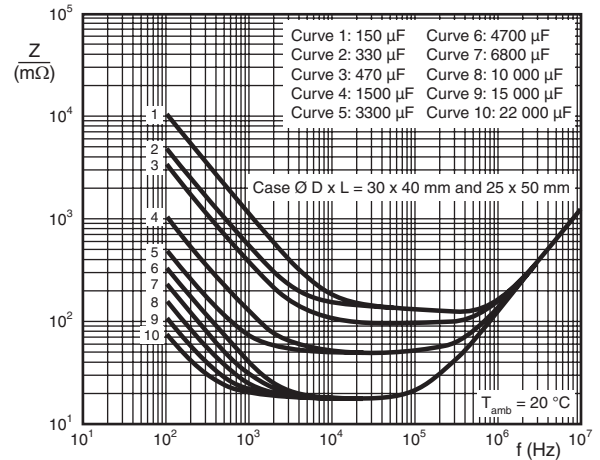


Fig.15 Typical impedance as a function of frequency

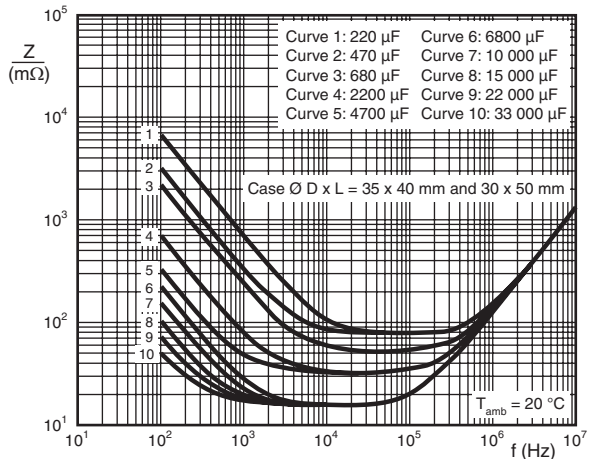


Fig.16 Typical impedance as a function of frequency

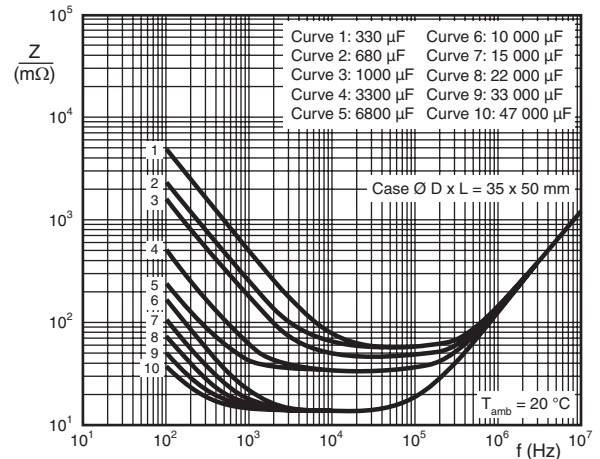
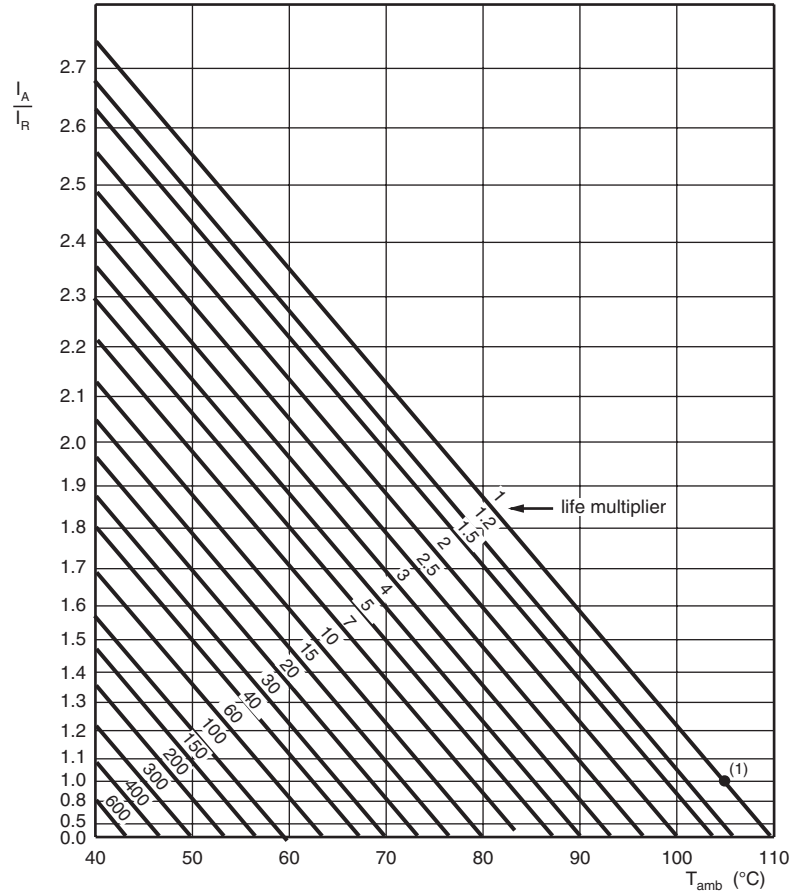


Fig.17 Typical impedance as a function of frequency



RIPPLE CURRENT AND USEFUL LIFE



I_A = actual ripple current at 100 Hz
 I_R = rated ripple current at 100 Hz and 105 °C
 (1) Useful life at 105 °C and I_R applied:
 5000 hours for ≤ 50 V types

Fig.18 Multiplier of useful life as a function of ambient temperature and ripple current load

Table 4

MULTIPLIER OF RIPPLE CURRENT (I_R) AS A FUNCTION OF FREQUENCY			
FREQUENCY (Hz)	I_R MULTIPLIER		
	$U_R = 10$ V to 25 V	$U_R = 40$ V to 100 V	$U_R > 100$ V
50	0.93	0.91	0.86
100	1.00	1.00	1.00
200	1.04	1.05	1.13
400	1.07	1.09	1.21
1000	1.11	1.13	1.29
2000	1.13	1.15	1.32
4000	1.15	1.18	1.35
$\geq 10\ 000$	1.18	1.22	1.40

Table 5

TEST PROCEDURES AND REQUIREMENTS			
TEST		PROCEDURE (quick reference)	REQUIREMENTS
NAME OF TEST	REFERENCE		
Endurance	IEC 60384-4/ EN130300 subclause 4.13	$T_{amb} = 105\text{ }^{\circ}\text{C}$; U_R applied; $\leq 50\text{ V}$ types: 2000 hours; $\geq 63\text{ V}$ types: 5000 hours	$U_R \leq 100\text{ V}$; $\Delta C/C$: $\pm 15\%$ $U_R > 100\text{ V}$; $\Delta C/C$: $\pm 10\%$ $ESR \leq 1.3 \times \text{spec. limit}$ $Z \leq 2 \times \text{spec. limit}$ $I_{L5} \leq \text{spec. limit}$
Useful life	CECC 30301 subclause 1.8.1	$T_{amb} = 105\text{ }^{\circ}\text{C}$; U_R and I_R applied; $\leq 50\text{ V}$ types: 5000 hours; $\geq 63\text{ V}$ types: 10 000 hours	$U_R \leq 100\text{ V}$; $\Delta C/C$: $\pm 45\%$ $U_R > 100\text{ V}$; $\Delta C/C$: $\pm 30\%$ $ESR \leq 3 \times \text{spec. limit}$ $Z \leq 3 \times \text{spec. limit}$ $I_{L5} \leq \text{spec. limit}$ no short or open circuit, no visible damage total failure percentage; $U_R > 100\text{ V}$: $\leq 3\%$
Shelf life (storage at high temperature)	IEC 60384-4/ EN130300 subclause 4.17	$T_{amb} = 105\text{ }^{\circ}\text{C}$; no voltage applied; 500 hours After test: U_R to be applied for 30 minutes 24 hours to 48 hours before measurement	$\Delta C/C$: $\pm 10\%$ $ESR \leq 1.2 \times \text{spec. limit}$ $I_{L5} \leq 2 \times \text{spec. limit}$

Aluminum Capacitors

MECHANICAL DATA

CLAMPS FOR ST TYPES

To facilitate vertical mounting, a series of rigid clamps is available. These are made of zinc plated steel, chromium(III) passivated, or stainless steel ($\varnothing D = 76 \text{ mm}$).

The clamps have either two or three mounting lugs, may be easily slipped over the capacitor and then clamped with a nut and bolt. Five types of clamps are available, one for each case diameter.

They are delivered without nuts or bolts, except for $\varnothing D = 90 \text{ mm}$, where they are included.

To avoid damaging the insulation sleeve, do not overtighten the clamp screw.



RoHS
COMPLIANT

DIMENSIONS in millimeters **AND AVAILABLE FORMS**

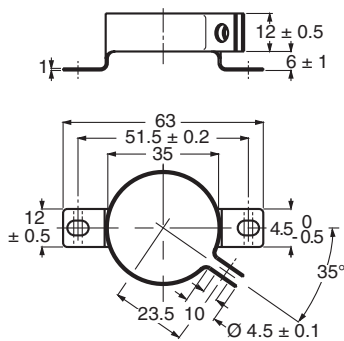


Fig.1 Dimensional outline of clamp for case $\varnothing D = 35 \text{ mm}$

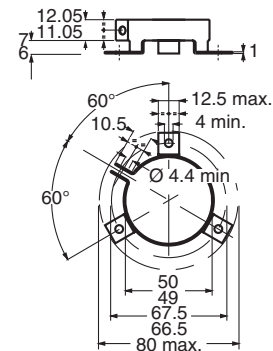


Fig.2 Dimensional outline of clamp for case $\varnothing D = 50 \text{ mm}$

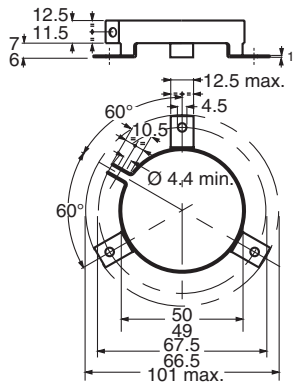


Fig.3 Dimensional outline of clamp for case $\varnothing D = 65 \text{ mm}$

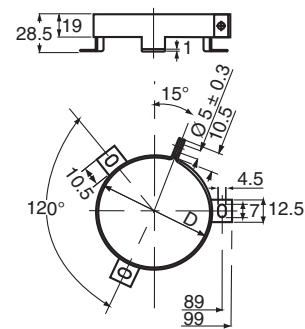


Fig.4 Dimensional outline of clamp for case $\varnothing D = 76 \text{ mm}$

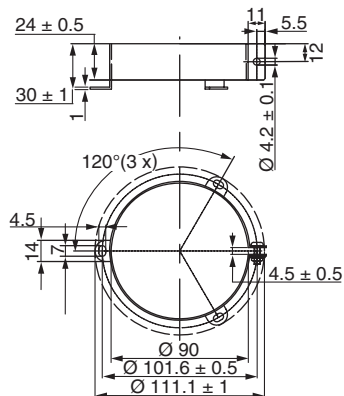


Fig.5 Dimensional outline of clamp for case $\varnothing D = 90 \text{ mm}$

Table 1

MOUNTING CLAMPS FOR SCREW TERMINALS	
CASE DIAMETER	ORDERING CODE
35	MAL804324031E3
50	MAL804324051E3
65	MAL804324061E3
76	MAL804323322E3
90	MAL804324921E3

NUTS AND WASHERS FOR STB-VERSIONS

When mounting with the bolt, which is an integral part of the case, standard metal M8 and M12 nuts and washers may be used; the maximum permissible torque is 4 Nm for M8 nuts and 10 Nm for M12 nuts.

If insulated mounting is required, synthetic nuts and rubber washers are available; for these nuts the maximum permissible torque is 2 Nm (M8) and 4 Nm (M12).

DIMENSIONS in millimeters AND AVAILABLE FORMS

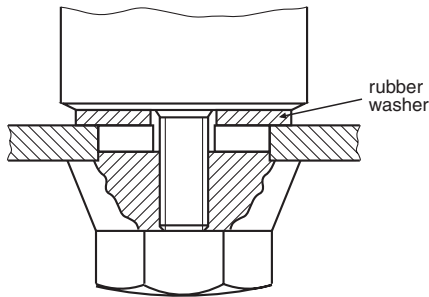


Fig.6 Insulated mounting

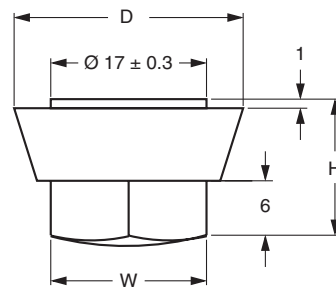


Fig.7 Synthetic cap nut; see Table 2 for dimensions D, H and W

Table 2

SYNTHETIC CAP NUTS						
CASE DIAMETER (mm)	THREAD	D (mm)	H (mm)	W ⁽¹⁾ (mm)	MIN. THREADED DEPTH (mm)	ORDERING CODE
35	M8	25	15	17	11.5	MAL804305561E3
≥ 50	M12	30	20	19	15.5	MAL804305571E3

Note

(1) Dimension W is measured across flats.

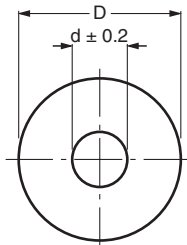


Fig.8 Rubber washer; thickness 2 mm

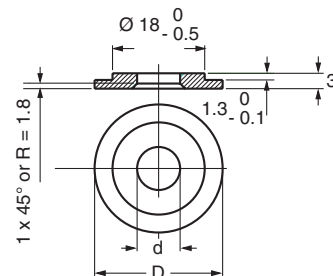


Fig.9 Insulating shoulder disk

RUBBER WASHERS		
D (mm)	d (mm)	ORDERING CODE
34	8.4	MAL204305591E3
49	13.0	MAL204305531E3
64	13.0	MAL204305521E3
74	13.0	MAL204313001E3

INSULATING SHOULDER DISKS		
D (mm)	d (mm)	ORDERING CODE
25	8.4	MAL804320381E3
30	12.5	MAL804320391E3

CLAMPS FOR SL-VERSIONS, $\varnothing D = 25, 30, 35$ and 40 mm

To facilitate vertical mounting, a series of rigid clamps made of zinc plated steel is available. These are made of zinc plated steel, chromium(III) passivated.

The clamps have two mounting lugs, may be easily slipped over the capacitor and then clamped with a nut and bolt. Four types of clamps are available, one for each case diameter.

They are delivered without nuts or bolts.

To avoid damaging the insulation sleeve, do not overtighten the clamp screw.



RoHS
COMPLIANT

DIMENSIONS in millimeters

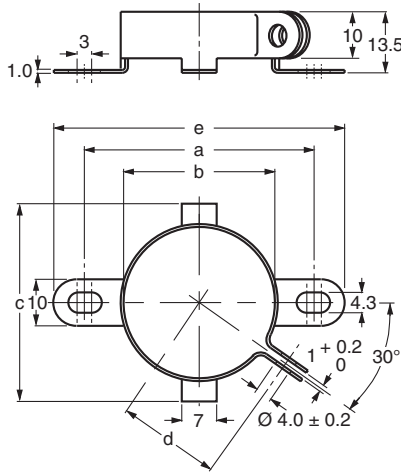


Fig.10 Dimensional outline of clamp for case $\varnothing D = 25, 30$ and 40 mm

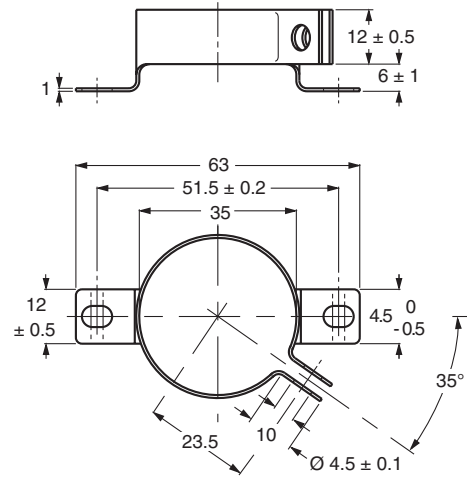


Fig.11 Dimensional outline of clamp for case $\varnothing D = 35$ mm

Table 3

MOUNTING CLAMPS FOR SOLDER LUGS						
CASE DIAMETER	a	b	c	d	e	ORDERING CODE
25	41.5 ± 0.2	25	35	18.5	56	MAL804324011E3
30	46.5 ± 0.2	30	40	21	61	MAL804324021E3
35	51.5 ± 0.2	35	-	23.5	63	MAL804324031E3
40	56.5 ± 0.2	40	50	26	71	MAL804324041E3

Aluminum Capacitors Power Eurodin Printed Wiring

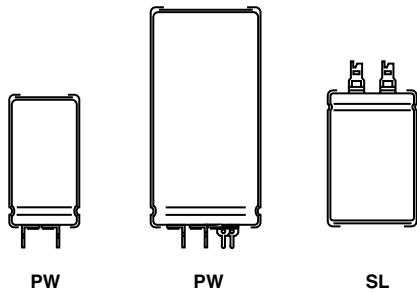
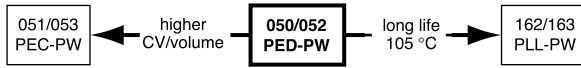


Fig.1 Component outlines



FEATURES

- Polarized aluminum electrolytic capacitors, non-solid electrolyte
- Large types, cylindrical aluminum case, insulated with a blue sleeve
- Provided with keyed polarity
- 050 series also available in solder-lug (SL) versions
- Very long useful life: 15 000 hours at 85 °C
- Low ESR, high ripple current capability
- High resistance to shock and vibration



APPLICATIONS

- Computer, telecommunication and industrial systems
- Smoothing and filtering
- Standard and switched mode power supplies
- Energy storage in pulse systems

MARKING

The capacitors are marked (where possible) with the following information:

- Rated capacitance (in μF)
- Tolerance on rated capacitance, code letter in accordance with IEC 60062 (Q for - 10 %/+ 30 %)
- Rated voltage (in V)
- Date code (YYMM)
- Name of manufacturer
- Code for factory of origin
- Polarity of the terminals and '-' sign to indicate the negative terminal, visible from the top and/or side of the capacitor
- Code number
- Climatic category in accordance with IEC 60068

QUICK REFERENCE DATA

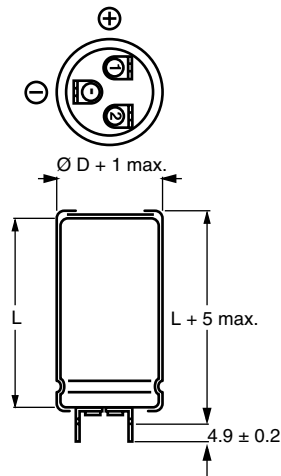
DESCRIPTION	VALUE	
	050	052
Nominal case size (\varnothing D x L in mm)	25 x 30 to 40 x 100	
Rated capacitance range (E6 series), C_R	470 μF to 68 000 μF	47 μF to 1000 μF
Tolerance on C_R	- 10 % to + 30 %	
Rated voltage range, U_R	10 V to 100 V	250 V to 400 V
Category temperature range	- 40 °C to + 85 °C	
Endurance test at 85 °C	5000 hours	
Useful life at 85 °C	15 000 hours	
Useful life at 40 °C, 1.4 x I_R applied	250 000 hours	
Shelf life at 0 V, 85 °C	500 hours	
Based on sectional specification	IEC 60384-4/EN130300	
Climatic category IEC 60068	40/085/56	

SELECTION CHART FOR C_R , U_R AND RELEVANT NOMINAL CASE SIZES FOR 050 SERIES (\varnothing D x L in mm)

C_R (μF)	U_R (V)					
	10	16	25	40	63	100
470	-	-	-	-	-	25 x 30
680	-	-	-	-	-	25 x 40
1000	-	-	-	-	25 x 30	30 x 40
1500	-	-	-	25 x 30	25 x 40	35 x 40
2200	-	-	25 x 30	25 x 40	30 x 40	35 x 50
3300	-	-	-	-	-	40 x 40
3300	-	25 x 30	25 x 40	30 x 40	35 x 40	40 x 50
4700	25 x 30	25 x 40	30 x 40	35 x 40	35 x 50	40 x 70
4700	-	-	-	-	40 x 40	-
6800	25 x 40	30 x 40	35 x 40	35 x 50	40 x 50	40 x 100
6800	-	-	-	40 x 40	-	-
10 000	30 x 40	35 x 40	35 x 50	40 x 50	40 x 70	-
10 000	-	-	40 x 40	-	-	-
15 000	35 x 40	35 x 50	40 x 50	40 x 70	40 x 100	-
15 000	-	40 x 40	-	-	-	-
22 000	35 x 50	40 x 50	40 x 70	40 x 100	-	-
22 000	40 x 40	-	-	-	-	-
33 000	40 x 50	40 x 70	40 x 100	-	-	-
47 000	40 x 70	40 x 100	-	-	-	-
68 000	40 x 100	-	-	-	-	-

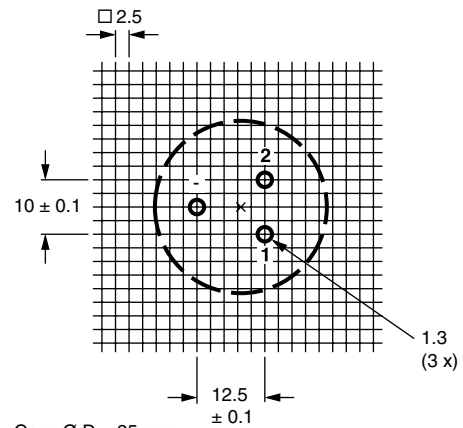
SELECTION CHART FOR C_R , U_R AND RELEVANT NOMINAL CASE SIZES FOR 052 SERIES ($\varnothing D \times L$)			
C_R (μF)	U_R (V)		
	250	385	400
47	-	25 x 30	25 x 30
68	-	25 x 40	25 x 40
100	25 x 30	30 x 40	30 x 40
150	25 x 40	35 x 40	35 x 40
220	30 x 40	35 x 50	35 x 50
	-	40 x 40	40 x 40
330	35 x 40	40 x 50	40 x 50
470	35 x 50	40 x 70	40 x 70
	40 x 40	-	-
680	40 x 50	-	40 x 100
1000	40 x 70	-	-

DIMENSIONS in millimeters **AND AVAILABLE FORMS**



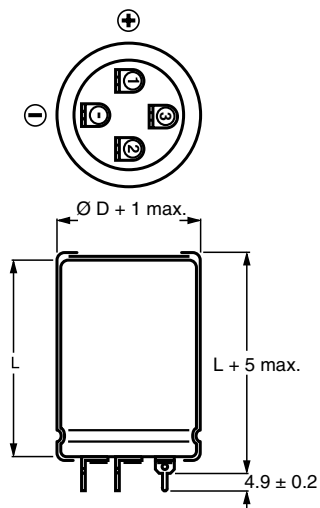
Case $\varnothing D = 25$ mm

Fig.2 Printed wiring pin version



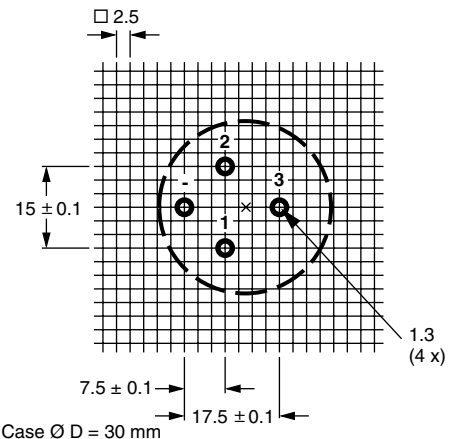
Case $\varnothing D = 25$ mm

Fig.3 Mounting hole diagram viewed from component side



Case $\varnothing D = 30$ mm

Fig.4 Printed wiring pin version



Case $\varnothing D = 30$ mm

Fig.5 Mounting hole diagram viewed from component side

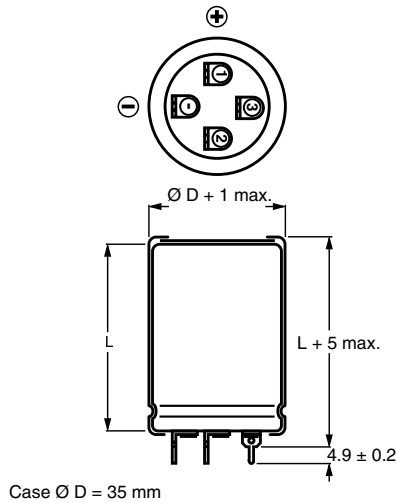


Fig.6 Printed wiring pin version

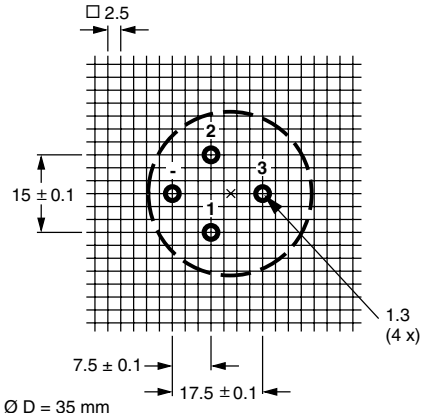


Fig.7 Mounting hole diagram viewed from component side

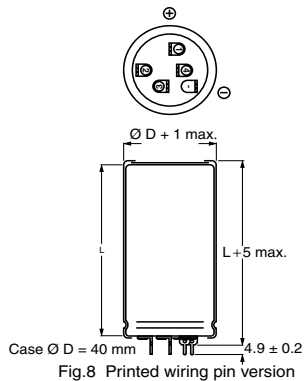


Fig.8 Printed wiring pin version

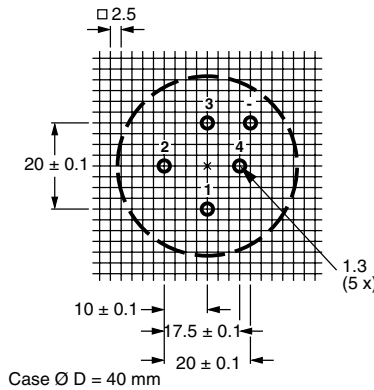


Fig.9 Mounting hole diagram viewed from component outside

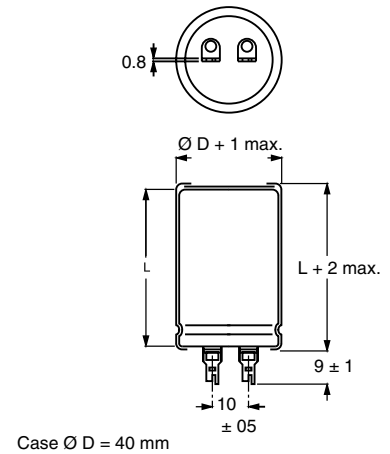


Fig.10 Solder-lug version (SL):
only available in 050 series

MOUNTING

When a number of capacitors are connected in a bank, they must not be closer together than 15 mm, when no derating of ripple current and/or temperature is applied.

Pin numbers 2, 3 and 4 (if present) must be free from the electrical circuit.

Table 1

DIMENSIONS in millimeters, MASS AND PACKAGING QUANTITIES						
NOMINAL CASE SIZE $\varnothing D \times L$	$\varnothing D_{max.}$	$L_{max.}$ SL VERSIONS	$L_{max.}$ PW VERSIONS	MASS (g)	PACKAGING QUANTITIES (units per box)	CARDBOARD BOX DIMENSIONS $L \times W \times H$
25 x 30	26	32	35	≈ 24	100	290 x 280 x 50
25 x 40	26	42	45	≈ 28	100	290 x 280 x 60
30 x 40	31	42	45	≈ 38	100	340 x 330 x 60
35 x 40	36	42	45	≈ 51	50	390 x 198 x 60
35 x 50	36	52	55	≈ 66	50	390 x 198 x 70
40 x 40 ⁽¹⁾	41	-	45	≈ 78	50	440 x 223 x 60
40 x 50	41	52	55	≈ 82	50	440 x 223 x 70
40 x 70	41	72	75	≈ 110	25	230 x 230 x 90
40 x 100	41	102	105	≈ 176	25	230 x 230 x 120

Note

⁽¹⁾ Not available in SL versions



Aluminum Capacitors
Power Eurodin Printed Wiring

050/052 PED-PW
Vishay BCcomponents

ELECTRICAL DATA	
SYMBOL	DESCRIPTION
C_R	rated capacitance at 100 Hz
I_R	rated RMS ripple current at 100 Hz, 85 °C or at 20 kHz, 70 °C
I_{L1}	max. leakage current after 1 minute at U_R
I_{L5}	max. leakage current after 5 minutes at U_R
ESR	max. equivalent series resistance at 100 Hz
Z	max. impedance at 10 kHz

ORDERING EXAMPLE

Electrolytic capacitor 050 series
10 000 μ F/25 V; - 10/+ 30 %
Nominal case size: \varnothing 35 x 50 mm; PW version
Ordering code: MAL205056103E3
Former 12NC: 222205056103

Note

- Unless otherwise specified, all electrical values in tables 2 and 3 apply at $T_{amb} = 20$ °C, P = 86 kPa to 106 kPa, RH = 45 % to 75 %

Table 2

ELECTRICAL DATA AND ORDERING INFORMATION FOR 050 SERIES										
U_R (V)	C_R 100 Hz (μ F)	NOMINAL CASE SIZE \varnothing D x L (mm)	I_R 100 Hz 85 °C (A)	I_R 20 kHz 70 °C (A)	I_{L1} 1 min (mA)	I_{L5} 5 min (mA)	ESR 100 Hz (m Ω)	Z 10 kHz (m Ω)	ORDERING CODE SL MAL2050.....	ORDERING CODE PW MAL2050.....
10	4700	25 x 30	2.4	4.6	0.28	0.10	74	50	14472E3	54472E3
	6800	25 x 40	3.2	6.1	0.41	0.14	51	37	14682E3	54682E3
	10 000	30 x 40	3.8	7.2	0.60	0.20	39	29	14103E3	54103E3
	15 000	35 x 40	4.1	7.8	0.90	0.30	35	26	14153E3	54153E3
	22 000	35 x 50	5.0	9.5	1.32	0.44	27	21	14223E3	54223E3
	22 000	40 x 40	4.2	8.0	1.32	0.44	36	27	not available	44223E3
	33 000	40 x 50	5.0	9.5	1.98	0.66	29	22	14333E3	54333E3
	47 000	40 x 70	6.8	12.9	2.82	0.94	20	17	14473E3	54473E3
68 000	40 x 100	9.2	17.5	4.08	1.36	15	14	14683E3	54683E3	
16	3300	25 x 30	2.4	4.6	0.32	0.11	75	50	15332E3	55332E3
	4700	25 x 40	3.1	5.9	0.45	0.15	52	37	15472E3	55472E3
	6800	30 x 40	3.7	7.0	0.65	0.22	40	30	15682E3	55682E3
	10 000	35 x 40	4.1	7.8	0.96	0.32	36	27	15103E3	55103E3
	15 000	35 x 50	5.0	9.5	1.44	0.48	28	21	15153E3	55153E3
	15 000	40 x 40	4.2	8.0	1.44	0.48	36	27	not available	45153E3
	22 000	40 x 50	5.0	9.5	2.12	0.71	29	22	15223E3	55223E3
	33 000	40 x 70	6.7	12.7	3.17	1.06	20	17	15333E3	55333E3
47 000	40 x 100	9.1	17.3	4.51	1.51	15	14	15473E3	55473E3	
25	2200	25 x 30	2.3	4.4	0.33	0.11	78	52	16222E3	56222E3
	3300	25 x 40	3.1	5.9	0.49	0.17	53	38	16332E3	56332E3
	4700	30 x 40	3.7	7.0	0.70	0.24	42	31	16472E3	56472E3
	6800	35 x 40	4.1	7.8	1.02	0.34	37	28	16682E3	56682E3
	10 000	35 x 50	5.0	9.5	1.50	0.50	28	21	16103E3	56103E3
	10 000	40 x 40	4.2	8.0	1.50	0.50	36	27	not available	46103E3
	15 000	40 x 50	5.0	9.5	2.25	0.75	29	22	16153E3	56153E3
	22 000	40 x 70	6.8	12.9	3.30	1.10	20	17	16223E3	56223E3
33 000	40 x 100	9.2	17.5	4.95	1.65	15	14	16333E3	56333E3	
40	1500	25 x 30	2.0	3.8	0.36	0.12	112	68	17152E3	57152E3
	2200	25 x 40	2.7	5.1	0.53	0.18	76	51	17222E3	57222E3
	3300	30 x 40	3.3	6.3	0.79	0.27	57	41	17332E3	57332E3
	4700	35 x 40	3.8	7.2	1.13	0.38	48	35	17472E3	57472E3
	6800	35 x 50	4.7	8.9	1.64	0.55	36	27	17682E3	57682E3
	6800	40 x 40	4.1	7.8	1.64	0.55	45	33	not available	47682E3
	10 000	40 x 50	4.9	9.3	2.40	0.80	35	27	17103E3	57103E3
	15 000	40 x 70	6.6	12.5	3.60	1.20	25	20	17153E3	57153E3
22 000	40 x 100	9.0	17.1	5.28	1.76	18	16	17223E3	57223E3	

ELECTRICAL DATA AND ORDERING INFORMATION FOR 050 SERIES										
U _R (V)	C _R 100 Hz (μF)	NOMINAL CASE SIZE Ø D x L (mm)	I _R 100 Hz 85 °C (A)	I _R 20 kHz 70 °C (A)	I _{L1} 1 min (mA)	I _{L5} 5 min (mA)	ESR 100 Hz (mΩ)	Z 10 kHz (mΩ)	ORDERING CODE SL MAL2050.....	ORDERING CODE PW MAL2050.....
63	1000	25 x 30	1.8	3.4	0.38	0.13	122	74	18102E3	58102E3
	1500	25 x 40	2.5	4.7	0.57	0.19	83	54	18152E3	58152E3
	2200	30 x 40	3.1	5.9	0.83	0.28	57	41	18222E3	58222E3
	3300	35 x 40	3.6	6.8	1.25	0.42	48	35	18332E3	58332E3
	4700	35 x 50	4.4	8.3	1.78	0.60	36	27	18472E3	58472E3
	4700	40 x 40	3.8	7.2	1.78	0.60	45	33	not available	48472E3
	6800	40 x 50	4.7	8.9	2.57	0.86	35	27	18682E3	58682E3
	10 000	40 x 70	6.2	11.8	3.78	1.26	25	20	18103E3	58103E3
	15 000	40 x 100	8.5	16.1	5.67	1.89	18	16	18153E3	58153E3
100	470	25 x 30	1.4	2.7	0.28	0.10	247	172	19471E3	59471E3
	680	25 x 40	1.9	3.6	0.41	0.14	170	116	19681E3	59681E3
	1000	30 x 40	2.5	4.7	0.60	0.20	123	88	19102E3	59102E3
	1500	35 x 40	3.1	5.8	0.90	0.30	94	71	19152E3	59152E3
	2200	35 x 50	3.9	7.4	1.32	0.44	69	55	19222E3	59222E3
	2200	40 x 40	3.6	6.8	1.32	0.44	81	65	not available	49222E3
	3300	40 x 50	4.6	8.7	1.98	0.66	59	48	19332E3	59332E3
	4700	40 x 70	6.2	11.7	2.82	0.94	42	36	19472E3	59472E3
	6800	40 x 100	8.2	15.5	4.08	1.36	32	28	19682E3	59682E3

Table 3

ELECTRICAL DATA AND ORDERING INFORMATION FOR 052 SERIES										
U _R (V)	C _R 100 Hz (μF)	NOMINAL CASE SIZE Ø D x L (mm)	I _R 100 Hz 85 °C (A)	I _R 20 kHz 70 °C (A)	I _{L1} 1 min (mA)	I _{L5} 5 min (mA)	ESR 100 Hz (mΩ)	Z 10 kHz (mΩ)	ORDERING CODE MAL2052.....	
250	100	25 x 30	0.6	1.15	0.15	0.05	1800	1300	53101E3	
	150	25 x 40	0.8	1.5	0.23	0.08	1100	850	53151E3	
	220	30 x 40	1.0	1.9	0.33	0.11	750	550	53221E3	
	330	35 x 40	1.4	2.65	0.49	0.17	500	400	53331E3	
	470	35 x 50	1.8	3.4	0.70	0.24	360	290	53471E3	
	470	40 x 40	1.8	3.4	0.70	0.24	420	350	43471E3	
	680	40 x 50	2.3	4.4	1.02	0.34	250	190	53681E3	
	1000	40 x 70	3.0	5.7	1.50	0.50	170	140	53102E3	
385	47	25 x 30	0.5	0.94	0.11	0.04	2370	1550	58479E3	
	68	25 x 40	0.67	1.27	0.16	0.06	1640	1100	58689E3	
	100	30 x 40	0.84	1.59	0.23	0.08	1275	950	58101E3	
	150	35 x 40	1.13	2.14	0.34	0.11	850	635	58151E3	
	220	35 x 50	1.48	2.8	0.50	0.17	580	430	58221E3	
	220	40 x 40	1.48	2.8	0.50	0.17	580	430	48221E3	
	330	40 x 50	1.97	3.73	0.75	0.25	385	300	58331E3	
	470	40 x 70	2.7	5.11	1.06	0.36	270	215	58471E3	
400	47	25 x 30	0.47	0.89	0.11	0.04	2700	2125	56479E3	
	68	25 x 40	0.63	1.29	0.16	0.06	1875	1470	56689E3	
	100	30 x 40	0.84	1.59	0.24	0.08	1275	1000	56101E3	
	150	35 x 40	1.13	2.14	0.36	0.12	850	665	56151E3	
	220	35 x 50	1.41	2.67	0.52	0.17	650	450	56221E3	
	220	40 x 40	1.41	2.67	0.52	0.17	650	450	46221E3	
	330	40 x 50	1.86	3.52	0.79	0.26	435	315	56331E3	
	470	40 x 70	2.54	4.81	1.12	0.37	305	225	56471E3	
680	40 x 100	3.56	6.75	1.63	0.54	210	155	56681E3		



ADDITIONAL ELECTRICAL DATA		
PARAMETER	CONDITIONS	VALUE
Voltage		
Surge voltage	≤ 250 V versions	$U_s = 1.15 \times U_R$
	≥ 385 V versions	$U_s = 1.1 \times U_R$
Reverse voltage		$U_{rev} \leq 1 \text{ V}$
Current		
Leakage current	After 1 minute at U_R	$I_{L1} \leq 0.006 C_R \times U_R + 4 \mu\text{A}$
	After 5 minutes at U_R	$I_{L5} \leq 0.002 C_R \times U_R + 4 \mu\text{A}$
Inductance		
Equivalent series inductance (ESL)	Case $\varnothing D = 25 \text{ mm}$	max. 25 nH
	Case $\varnothing D = 30 \text{ and } 35 \text{ mm}$	max. 30 nH
	Case $\varnothing D = 40 \text{ mm}$	max. 35 nH

CAPACITANCE (C)

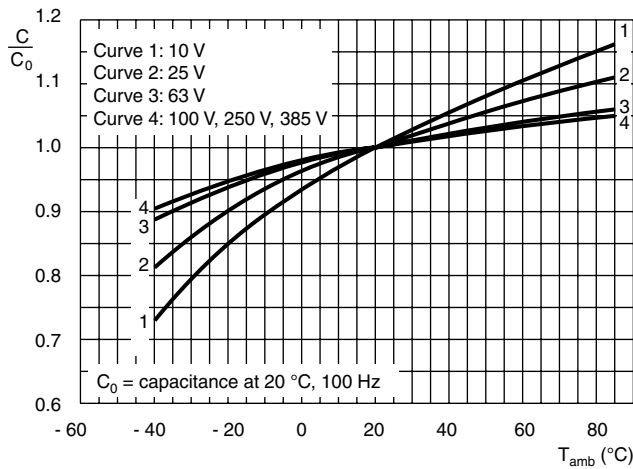


Fig.11 Typical multiplier of capacitance as a function of ambient temperature

EQUIVALENT SERIES RESISTANCE (ESR)

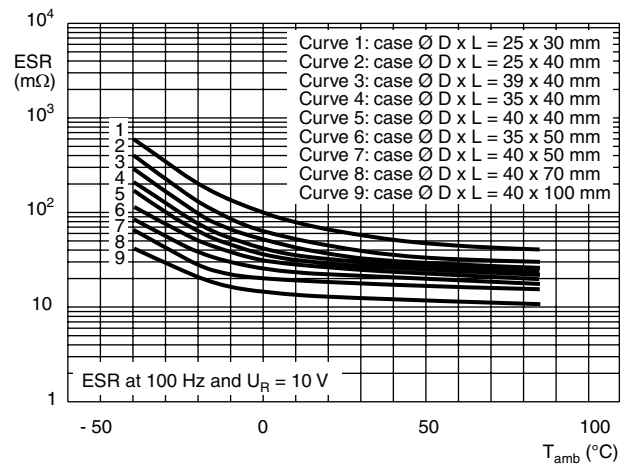


Fig.12 Typical ESR as a function of temperature

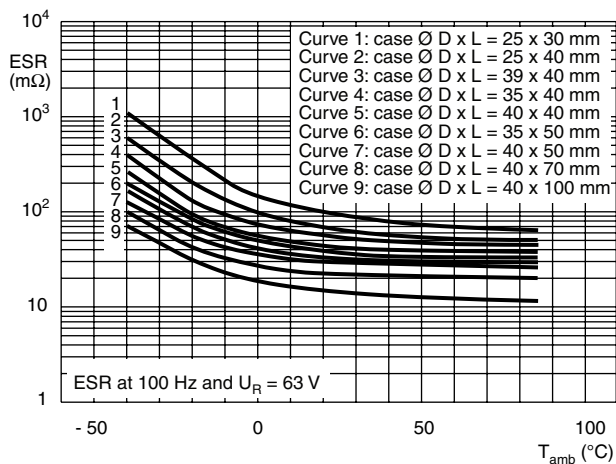


Fig.13 Typical ESR as a function of temperature

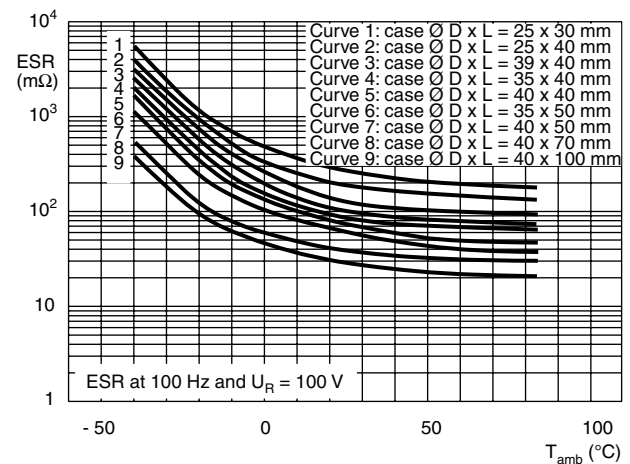


Fig.14 Typical ESR as a function of temperature



EQUIVALENT SERIES RESISTANCE (ESR)

IMPEDANCE (Z)

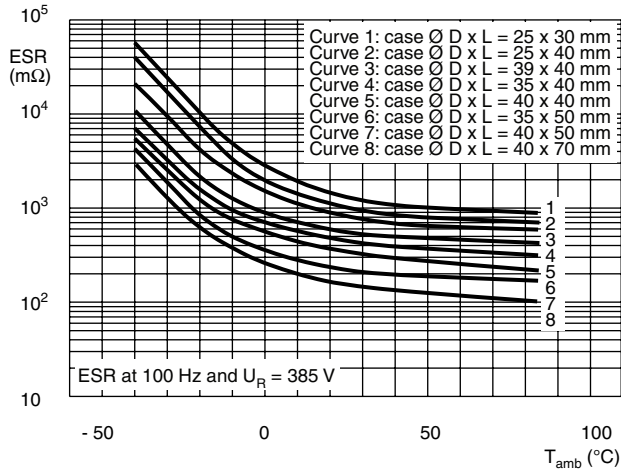


Fig.15 Typical ESR as a function of temperature

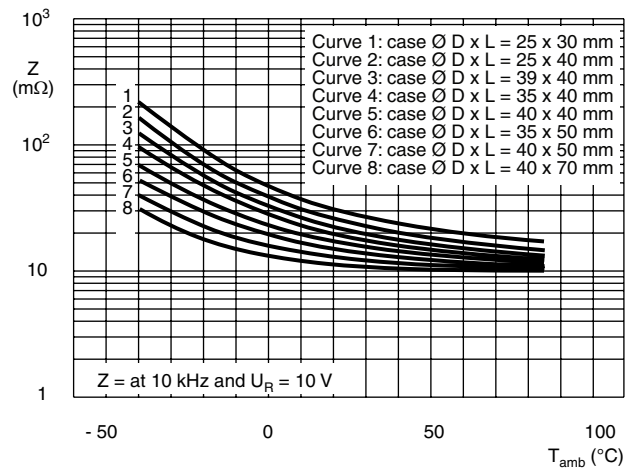


Fig.16 Typical impedance as a function of temperature

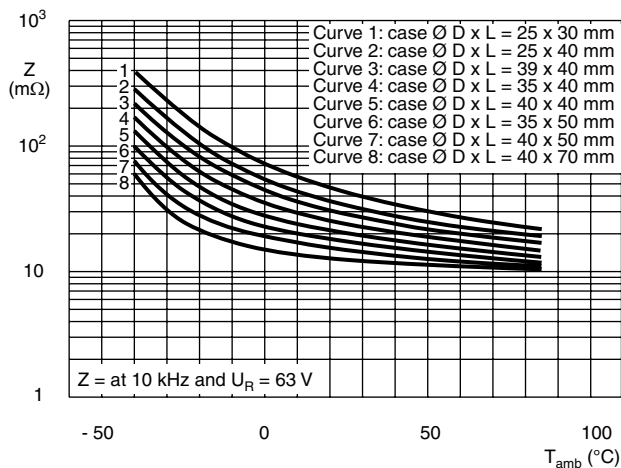


Fig.17 Typical impedance as a function of temperature

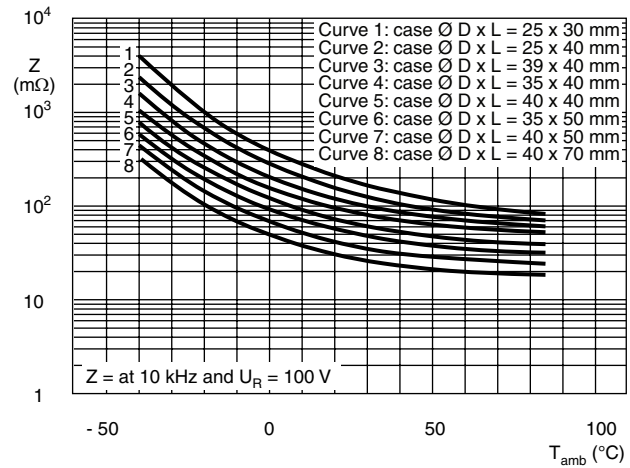


Fig.18 Typical impedance as a function of temperature

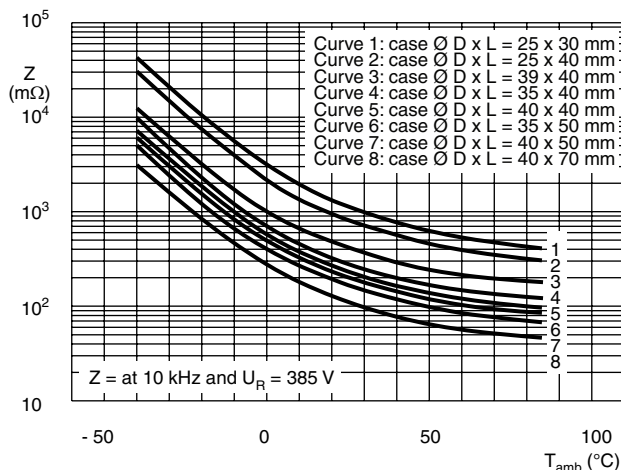


Fig.19 Typical impedance as a function of temperature

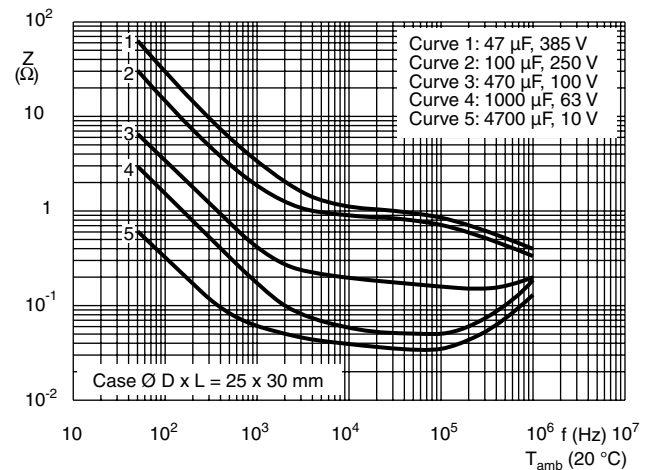


Fig.20 Typical impedance as a function of temperature



IMPEDANCE (Z)

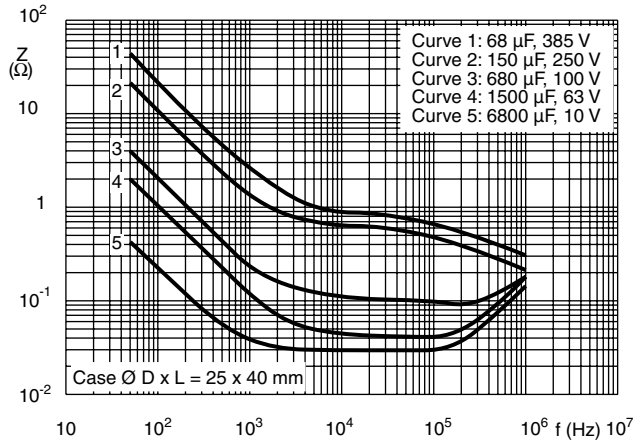


Fig.21 Typical impedance as a function of frequency

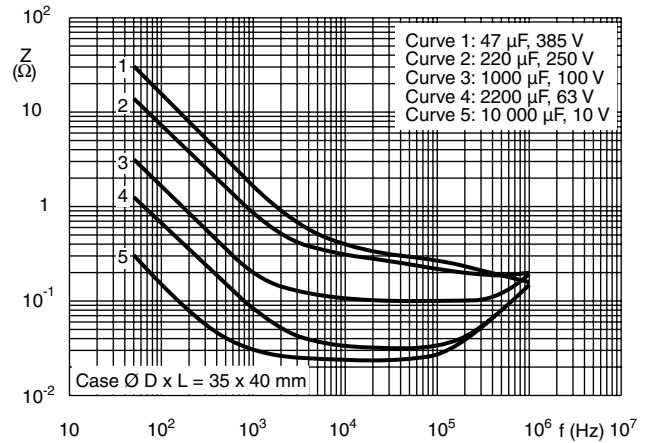


Fig.22 Typical impedance as a function of frequency

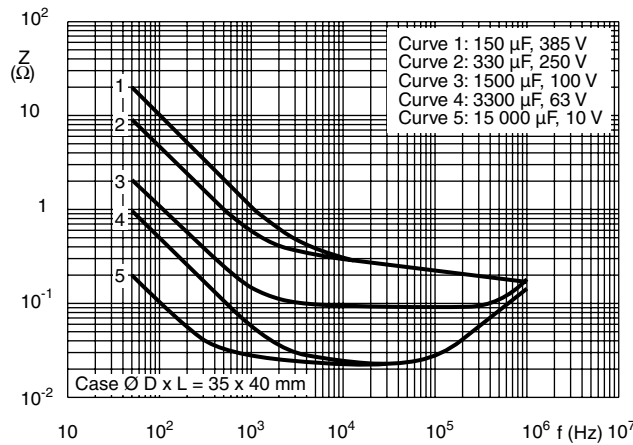


Fig.23 Typical impedance as a function of frequency

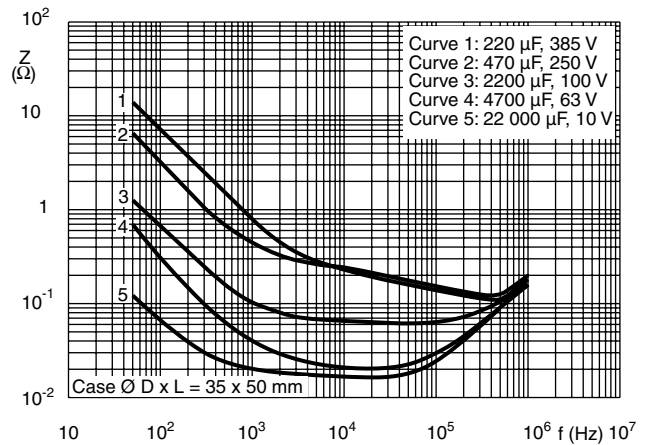


Fig.24 Typical impedance as a function of frequency

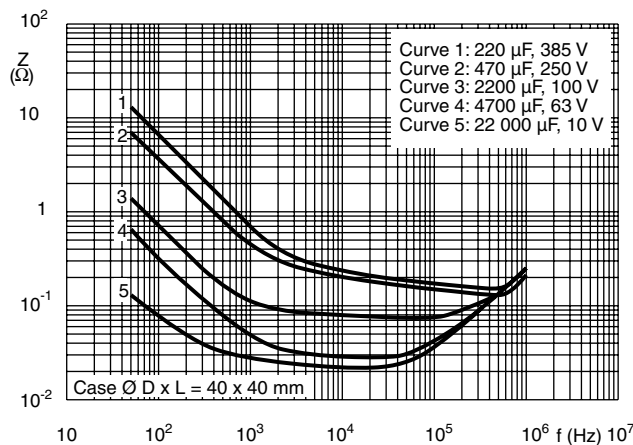


Fig.25 Typical impedance as a function of frequency

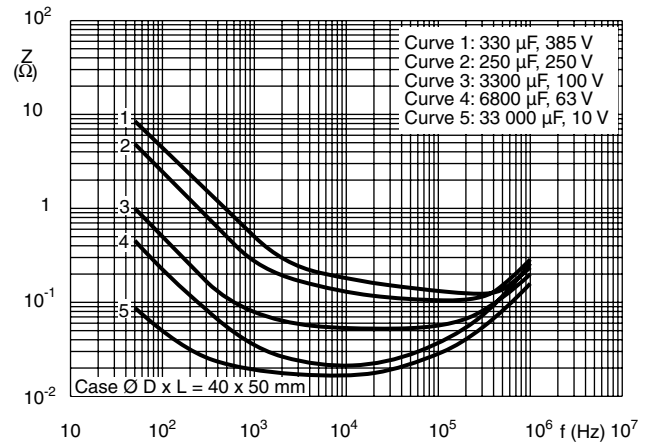


Fig.26 Typical impedance as a function of frequency

IMPEDANCE (Z)

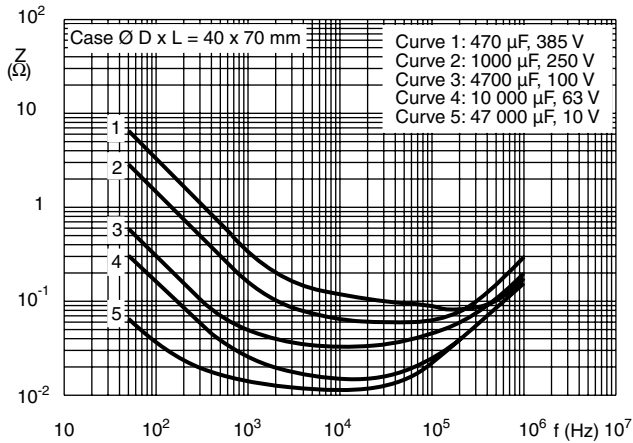


Fig.27 Typical impedance as a function of frequency

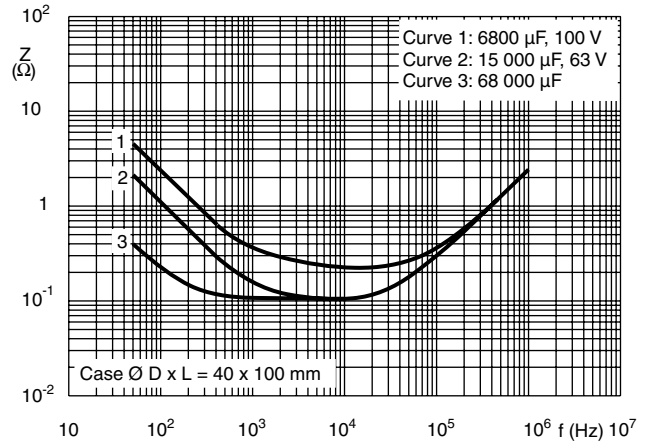
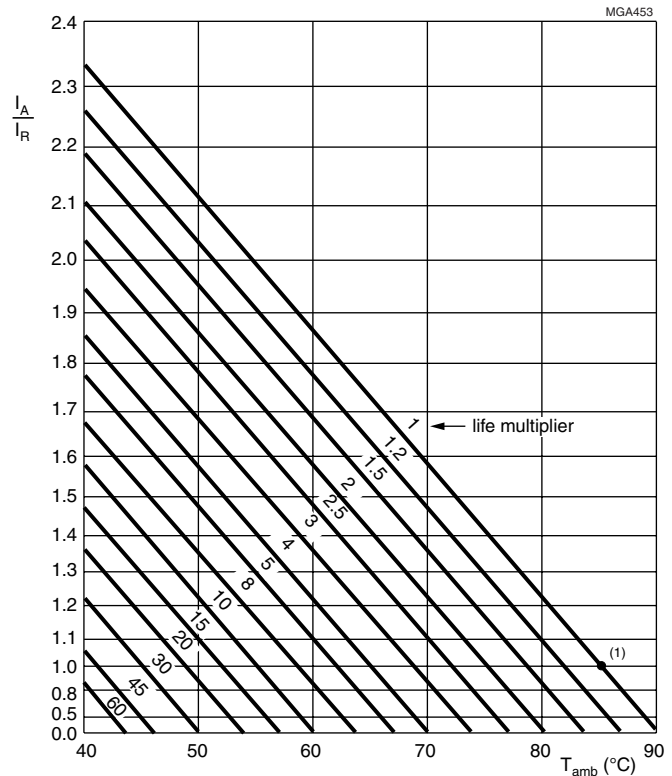


Fig.28 Typical impedance as a function of frequency

RIPPLE CURRENT AND USEFUL LIFE



I_A = actual ripple current
 I_R = rated ripple current at 100 Hz and 85 °C
 (1) Useful life at 85 °C and I_R applied: 15 000 hours

Fig.29 Multiplier of useful life as a function of ambient temperature and ripple current load.



Table 4

MULTIPLIER OF RIPPLE CURRENT (I_R) AS A FUNCTION OF FREQUENCY	
FREQUENCY (Hz)	I_R MULTIPLIER
50	0.83
100	1.00
200	1.10
400	1.15
1000	1.19
≥ 2000	1.20

Table 5

TEST PROCEDURES AND REQUIREMENT			
TEST		PROCEDURE (quick reference)	REQUIREMENTS
NAME OF TEST	REFERENCE		
Endurance	IEC 60384-4/ EN130300 subclause 4.13	$T_{amb} = 85\text{ }^\circ\text{C}$; U_R applied; 5000 hours	$U_R \leq 100\text{ V}$; $\Delta C/C: \pm 15\%$ $U_R > 100\text{ V}$; $\Delta C/C: \pm 10\%$ $ESR \leq 1.3 \times \text{spec. limit}$ $Z \leq 2 \times \text{spec. limit}$ $I_{L5} \leq \text{spec. limit}$
Useful life	CECC 30301 subclause 1.8.1	$T_{amb} = 85\text{ }^\circ\text{C}$; U_R and I_R applied; 15 000 hours	$U_R \leq 100\text{ V}$; $\Delta C/C: \pm 45\%$ $U_R > 100\text{ V}$; $\Delta C/C: \pm 30\%$ $ESR \leq 3 \times \text{spec. limit}$ $Z \leq 3 \times \text{spec. limit}$ $I_{L5} \leq \text{spec. limit}$ no short or open circuit, no visible damage total failure percentage: $U_R \leq 100\text{ V}: \leq 1\%$; $U_R > 100\text{ V}: \leq 3\%$
Shelf life (storage at high temperature)	IEC 60384-4/ EN130300 subclause 4.17	$T_{amb} = 85\text{ }^\circ\text{C}$; no voltage applied; 500 hours after test: U_R to be applied for 30 minutes, 24 hours to 48 hours before measurement	$\Delta C/C: \pm 10\%$ $ESR \leq 1.2 \times \text{spec. limit}$ $I_{L5} \leq 2 \times \text{spec. limit}$

Aluminum Capacitors Power Economic Printed Wiring

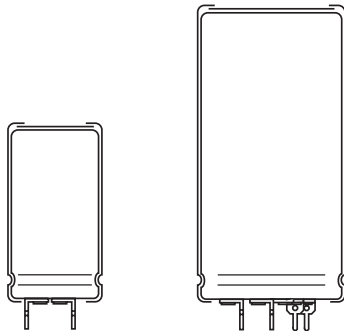
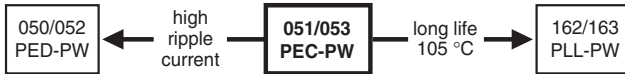


Fig.1 Component outlines



RoHS
COMPLIANT

FEATURES

- Polarized aluminum electrolytic capacitors, non-solid electrolyte
- Large types with reduced dimensions, cylindrical aluminum case, insulated with a blue sleeve
- Provided with keyed polarity
- Long useful life: 12 000 hours at 85 °C
- High ripple current capability
- High resistance to shock and vibration

APPLICATIONS

- General purpose, industrial, medical and audio/video systems
- Standard and switched mode power supplies
- Energy storage in pulse systems

MARKING

The capacitors are marked (where possible) with the following information:

- Rated capacitance (in μF)
- Tolerance on rated capacitance, code letter in accordance with IEC 60062 (M for $\pm 20\%$)
- Rated voltage (in V)
- Date code (YYMM)
- Name of manufacturer
- Code for factory of origin
- Polarity of the terminals and '-' sign to indicate the negative terminal, visible from the top and/or side of the capacitor
- Code number
- Climatic category in accordance with IEC 60068

QUICK REFERENCE DATA

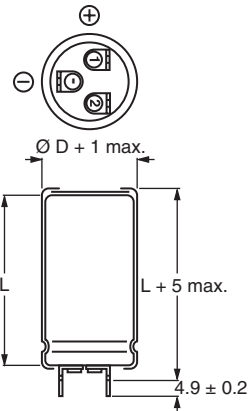
DESCRIPTION	VALUE	
	051	053
Nominal case size ($\varnothing D \times L$ in mm)	25 x 30 to 40 x 100	
Rated capacitance range (E6 series), C_R	680 μF to 150 000 μF	68 μF to 2200 μF
Tolerance on C_R	$\pm 20\%$	
Rated voltage range, U_R	10 V to 100 V	200 V to 400 V
Category temperature range	- 40 °C to + 85 °C	
Endurance test at 85 °C	5000 hours	
Useful life at 85 °C	12 000 hours	
Useful life at 40 °C, 1.4 x I_R applied	200 000 hours	
Shelf life at 0 V, 85 °C	500 hours	
Based on sectional specification	IEC 60384-4/EN130300	
Climatic category IEC 60068	40/085/56	

SELECTION CHART FOR C_R , U_R AND RELEVANT NOMINAL CASE SIZES ($\varnothing D \times L$ in mm)

C_R (μF)	U_R (V)								
	10	16	25	40	63	100	200	385	400
68	-	-	-	-	-	-	-	25 x 30	25 x 30
100	-	-	-	-	-	-	-	25 x 40	25 x 40
150	-	-	-	-	-	-	25 x 30	30 x 40	30 x 40
220	-	-	-	-	-	-	25 x 40	35 x 40	35 x 40
330	-	-	-	-	-	-	30 x 40	35 x 50	35 x 50
	-	-	-	-	-	-	-	40 x 40	40 x 40
470	-	-	-	-	-	-	35 x 40	40 x 50	40 x 50
680	-	-	-	-	-	25 x 30	35 x 50	40 x 70	40 x 70
	-	-	-	-	-	-	40 x 40	-	-
1000	-	-	-	-	-	25 x 40	40 x 50	40 x 100	40 x 100
1500	-	-	-	-	-	30 x 40	40 x 70	-	-
2200	-	-	-	-	25 x 30	35 x 40	40 x 100	-	-

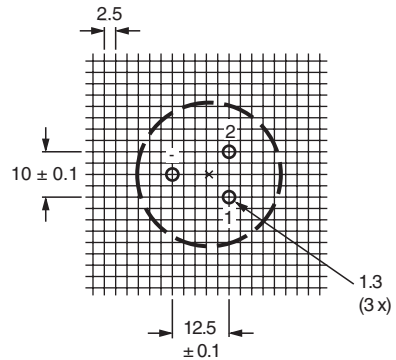
SELECTION CHART FOR C_R , U_R AND RELEVANT NOMINAL CASE SIZES ($\varnothing D \times L$ in mm)									
C_R (μF)	U_R (V)								
	10	16	25	40	63	100	200	385	400
3300	-	-	-	25 x 30	25 x 40	35 x 50	-	-	-
	-	-	-	-	-	40 x 40	-	-	-
4700	-	-	25 x 30	25 x 40	30 x 40	40 x 50	-	-	-
6800	-	25 x 30	25 x 40	30 x 40	35 x 40	40 x 70	-	-	-
10 000	25 x 30	25 x 40	30 x 40	35 x 40	35 x 50	40 x 100	-	-	-
	-	-	-	-	40 x 40	-	-	-	-
15 000	25 x 40	30 x 40	35 x 40	35 x 50	40 x 70	-	-	-	-
	-	-	-	40 x 40	-	-	-	-	-
22 000	30 x 40	35 x 40	35 x 50	40 x 50	40 x 100	-	-	-	-
	-	-	40 x 40	-	-	-	-	-	-
33 000	35 x 40	35 x 50	40 x 50	40 x 70	-	-	-	-	-
	-	40 x 40	-	-	-	-	-	-	-
47 000	35 x 50	40 x 50	40 x 70	40 x 100	-	-	-	-	-
	40 x 40	-	-	-	-	-	-	-	-
68 000	40 x 50	40 x 70	40 x 100	-	-	-	-	-	
100 000	40 x 70	40 x 100	-	-	-	-	-	-	
150 000	40 x 100	-	-	-	-	-	-	-	

DIMENSIONS in millimeters **AND AVAILABLE FORMS**



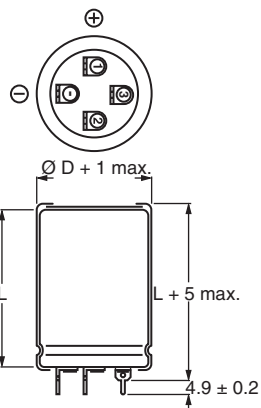
Case $\varnothing D = 25$ mm

Fig.2 Printed wiring pin version



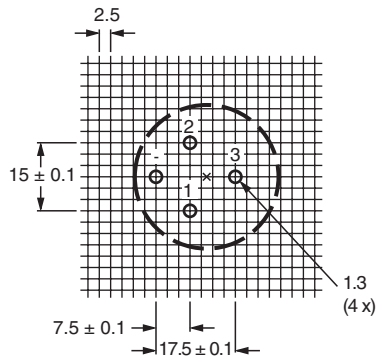
Case $\varnothing D = 25$ mm

Fig.3 Mounting hole diagram viewed from component side



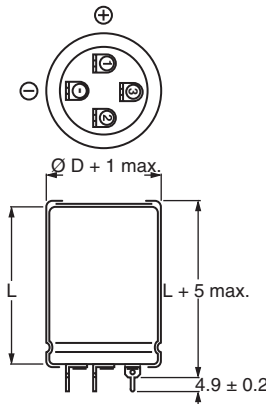
Case $\varnothing D = 30$ mm

Fig.4 Printed wiring pin version



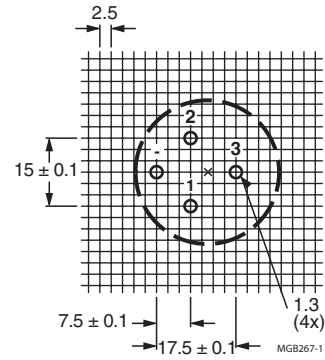
Case $\varnothing D = 30$ mm

Fig.5 Mounting hole diagram viewed from component side



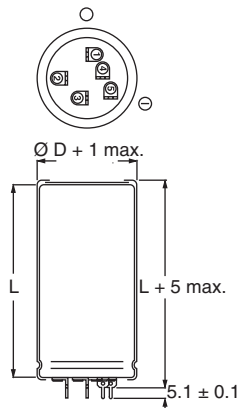
Case Ø D = 35 mm

Fig.6 Printed wiring pin version



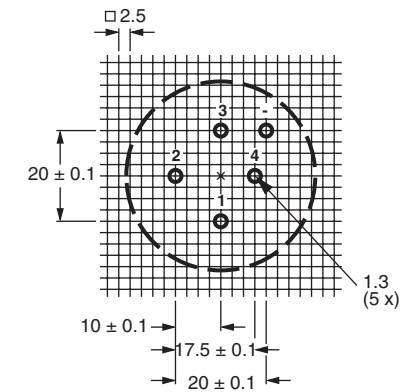
Case Ø D = 35 mm

Fig. 7 Mounting hole diagram viewed from component side



Case Ø D = 40 mm

Fig.8 Printed wiring pin version



Case Ø D = 40 mm

Fig.9 Mounting hole diagram viewed from component outside

Case Ø D = 40 mm

Fig.9 Mounting hole diagram viewed from component side

Table 1

DIMENSIONS in millimeters, MASS AND PACKAGING QUANTITIES PW versions					
NOMINAL CASE SIZE Ø D x L	Ø D _{max.}	L _{max.}	MASS (g)	PACKAGING QUANTITIES (units per box)	CARDBOARD BOX DIMENSIONS L x W x H
25 x 30	26	35	≈ 24	100	290 x 280 x 50
25 x 40	26	45	≈ 28	100	290 x 280 x 60
30 x 40	31	45	≈ 38	100	340 x 330 x 60
35 x 40	36	45	≈ 51	50	390 x 198 x 60
35 x 50	36	55	≈ 66	50	390 x 198 x 70
40 x 40	41	45	≈ 78	50	440 x 223 x 60
40 x 50	41	55	≈ 82	50	440 x 223 x 70
40 x 70	41	75	≈ 110	25	230 x 230 x 90
40 x 100	41	105	≈ 176	25	230 x 230 x 120

MOUNTING

When a number of capacitors are connected in a bank, they must not be closer together than 15 mm, when no derating of ripple current and/or temperature is applied.

Pin numbers 2, 3 and 4 (if present) must be free from the electrical circuit.



ELECTRICAL DATA	
SYMBOL	DESCRIPTION
C_R	rated capacitance at 100 Hz
I_R	rated RMS ripple current at 100 Hz, 85 °C or at 20 kHz, 70 °C
I_{L1}	max. leakage current after 1 minute at U_R
I_{L5}	max. leakage current after 5 minutes at U_R
ESR	max. equivalent series resistance at 100 Hz
Z	max. impedance at 10 kHz

ORDERING EXAMPLE

Electrolytic capacitor 051 series

10 000 μ F/25 V; \pm 20 %

Nominal case size: \varnothing 30 mm x 40 mm

Ordering code: MAL205156103E3

Former 12NC: 222205156103

Note

- Unless otherwise specified, all electrical values in tables 2 and 3 apply at $T_{amb} = 20$ °C, P = 86 kPa to 106 kPa, RH = 45 % to 75 %

Table 2

ELECTRICAL DATA AND ORDERING INFORMATION 051 SERIES									
U_R (V)	C_R 100 Hz (μ F)	NOMINAL CASE SIZE \varnothing D x L (mm)	I_R 100 Hz 85 °C (A)	I_R 20 kHz 70 °C (A)	I_{L1} 1 min (mA)	I_{L5} 5 min (mA)	ESR 100 Hz (m Ω)	Z 10 kHz (m Ω)	ORDERING CODE MAL2051.....
10	10 000	25 x 30	3.1	5.9	0.60	0.20	51	40	54103E3
	15 000	25 x 40	4.1	7.8	0.90	0.30	37	30	54153E3
	22 000	30 x 40	5.0	9.5	1.32	0.44	30	25	54223E3
	33 000	35 x 40	5.5	10.4	1.98	0.66	28	24	54333E3
	47 000	35 x 50	6.8	12.9	2.82	0.94	23	20	54473E3
	47 000	40 x 40	5.8	10.4	2.82	0.94	29	22	44473E3
	68 000	40 x 50	7.1	13.5	4.08	1.36	24	20	54683E3
	100 000	40 x 70	9.2	17.4	6.00	2.00	19	16	54104E3
150 000	40 x 100	12.0	22.7	9.00	3.00	16	14	54154E3	
16	6800	25 x 30	3.1	5.9	0.65	0.22	53	42	55682E3
	10 000	25 x 40	4.0	7.6	0.96	0.32	39	34	55103E3
	15 000	30 x 40	5.0	9.5	1.44	0.48	31	27	55153E3
	22 000	35 x 40	5.5	10.4	2.12	0.71	29	26	55223E3
	33 000	35 x 50	6.7	12.7	3.17	1.06	23	21	55333E3
	33 000	40 x 40	5.7	10.8	3.17	1.06	30	24	45333E3
	47 000	40 x 50	7.0	13.3	4.52	1.51	24	20	55473E3
	68 000	40 x 70	9.2	17.4	6.53	2.18	19	16	55683E3
100 000	40 x 100	12.0	22.7	9.60	3.20	16	14	55104E3	
25	4700	25 x 30	2.9	5.5	0.71	0.24	60	42	56472E3
	6800	25 x 40	3.9	7.4	1.02	0.34	42	34	56682E3
	10 000	30 x 40	4.8	9.1	1.50	0.50	34	27	56103E3
	15 000	35 x 40	5.3	10.0	2.25	0.75	30	26	56153E3
	22 000	35 x 50	6.5	12.3	3.30	1.10	24	21	56223E3
	22 000	40 x 40	5.7	10.8	3.30	1.10	31	24	46223E3
	33 000	40 x 50	7.0	13.3	4.95	1.65	25	20	56333E3
	47 000	40 x 70	9.2	17.4	7.05	2.35	19	16	56473E3
68 000	40 x 100	12.0	22.7	10.20	3.40	16	14	56683E3	
40	3300	25 x 30	2.9	5.5	0.80	0.27	87	63	57332E3
	4700	25 x 40	3.8	7.2	1.13	0.38	62	47	57472E3
	6800	30 x 40	4.7	8.9	1.64	0.55	49	38	57682E3
	10 000	35 x 40	5.2	9.8	2.40	0.80	48	37	57103E3
	15 000	35 x 50	6.3	11.9	3.60	1.20	37	28	57153E3
	15 000	40 x 40	5.6	10.6	3.60	1.20	50	35	47153E3
	22 000	40 x 50	5.8	11.0	5.28	1.76	39	28	57223E3
	33 000	40 x 70	7.8	14.8	7.92	2.64	28	21	57333E3
47 000	40 x 100	10.4	19.7	11.28	3.76	22	17	57473E3	

ELECTRICAL DATA AND ORDERING INFORMATION 051 SERIES									
U_R (V)	C_R 100 Hz (μ F)	NOMINAL CASE SIZE \varnothing D x L (mm)	I_R 100 Hz 85 °C (A)	I_R 20 kHz 70 °C (A)	I_{L1} 1 min (mA)	I_{L5} 5 min (mA)	ESR 100 Hz (m Ω)	Z 10 kHz (m Ω)	ORDERING CODE MAL2051.....
63	2200	25 x 30	2.5	4.7	0.84	0.28	83	62	58222E3
	3300	25 x 40	3.3	6.2	1.25	0.42	58	42	58332E3
	4700	30 x 40	4.1	7.8	1.78	0.60	49	38	58472E3
	6800	35 x 40	4.5	8.5	2.57	0.86	48	37	58682E3
	10 000	35 x 50	5.4	10.2	3.78	1.26	37	28	58103E3
	10 000	40 x 40	4.6	8.7	3.78	1.26	52	37	48103E3
	15 000	40 x 70	7.5	14.2	5.67	1.89	29	24	58153E3
	22 000	40 x 100	10.0	19.0	8.32	2.77	22	19	58223E3
100	680	25 x 30	1.74	3.30	0.41	0.14	190	130	59681E3
	1000	25 x 40	2.34	4.44	0.60	0.20	130	90	59102E3
	1500	30 x 40	2.95	5.59	0.90	0.30	95	67	59152E3
	2200	35 x 40	3.69	7.00	1.32	0.44	71	53	59222E3
	3300	35 x 50	4.37	8.29	1.98	0.66	55	41	59332E3
	3300	40 x 40	4.16	7.89	1.98	0.66	64	48	49332E3
	4700	40 x 50	5.21	9.88	2.82	0.94	49	38	59472E3
	6800	40 x 70	6.97	13.22	4.08	1.36	35	28	59682E3
	10 000	40 x 100	9.50	18.00	6.00	2.00	26	21	59103E3

Table 3

ELECTRICAL DATA AND ORDERING INFORMATION 053 SERIES									
U_R (V)	C_R 100 Hz (μ F)	NOMINAL CASE SIZE \varnothing D x L (mm)	I_R 100 Hz 85 °C (A)	I_R 20 kHz 70 °C (A)	I_{L1} 1 min (mA)	I_{L5} 5 min (mA)	ESR 100 Hz (m Ω)	Z 10 kHz (m Ω)	ORDERING CODE MAL2053.....
200	150	25 x 30	0.70	1.33	0.18	0.06	1000	770	52151E3
	220	25 x 40	0.94	1.78	0.26	0.09	680	525	52221E3
	330	30 x 40	1.27	2.41	0.40	0.14	460	360	52331E3
	470	35 x 40	1.66	3.15	0.57	0.19	320	250	52471E3
	680	35 x 50	2.19	4.15	0.82	0.28	220	170	52681E3
	680	40 x 40	2.17	4.11	0.82	0.28	220	170	42681E3
	1000	40 x 50	2.86	5.42	1.20	0.40	150	115	52102E3
	1500	40 x 70	3.81	7.22	1.80	0.60	110	85	52152E3
2200	40 x 100	5.20	9.86	2.64	0.88	80	60	52222E3	
385	68	25 x 30	0.47	0.89	0.16	0.06	2200	1480	58689E3
	100	25 x 40	0.64	1.21	0.23	0.08	1500	1020	58101E3
	150	30 x 40	0.90	1.71	0.35	0.12	1000	700	58151E3
	220	35 x 40	1.15	2.18	0.51	0.17	680	480	58221E3
	330	35 x 50	1.53	2.90	0.77	0.26	450	340	58331E3
	330	40 x 40	1.52	2.88	0.77	0.26	450	340	48331E3
	470	40 x 50	1.96	3.72	1.09	0.36	320	260	58471E3
	680	40 x 70	2.70	5.12	1.58	0.53	220	190	58681E3
1000	40 x 100	3.70	7.02	2.31	0.78	180	140	58102E3	
400	68	25 x 30	0.54	1.02	0.16	0.06	2100	1000	56689E3
	100	25 x 40	0.73	1.38	0.24	0.08	1400	780	56101E3
	150	30 x 40	0.98	1.86	0.36	0.12	950	520	56151E3
	220	35 x 40	1.28	2.43	0.52	0.17	650	400	56221E3
	330	35 x 50	1.67	3.17	0.79	0.26	480	280	56331E3
	330	40 x 40	1.67	3.17	0.79	0.26	480	280	46331E3
	470	40 x 50	2.12	4.02	1.12	0.37	340	220	56471E3
	680	40 x 70	2.90	5.50	1.63	0.54	235	155	56681E3
1000	40 x 100	4.05	7.68	2.40	0.80	160	110	56102E3	



ADDITIONAL ELECTRICAL DATA		
PARAMETER	CONDITIONS	VALUE
Voltage		
Surge voltage	≤ 250 V versions	$U_s = 1.15 \times U_R$
	≥ 385 V versions	$U_s = 1.1 \times U_R$
Reverse voltage		$U_{rev} \leq 1 \text{ V}$
Current		
Leakage current	After 1 minute at U_R	$I_{L1} \leq 0.006 C_R \times U_R + 4 \mu\text{A}$
	After 5 minutes at U_R	$I_{L5} \leq 0.002 C_R \times U_R + 4 \mu\text{A}$
Inductance		
Equivalent series inductance (ESL)	Case $\varnothing D = 25 \text{ mm}$	max. 25 nH
	Case $\varnothing D = 30 \text{ and } 35 \text{ mm}$	max. 30 nH
	Case $\varnothing D = 40 \text{ mm}$	max. 35 nH

CAPACITANCE (C)

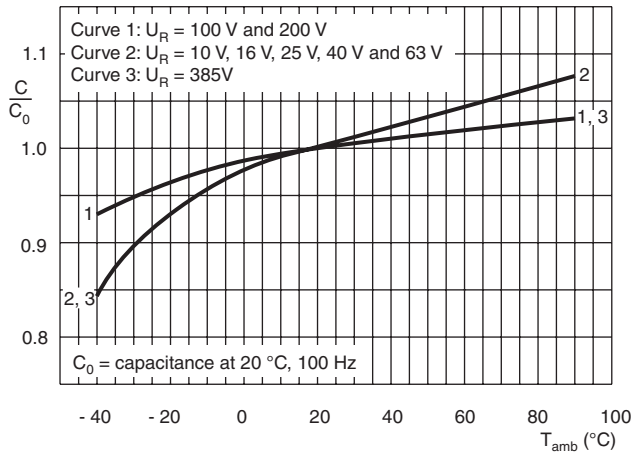


Fig.10 Typical multiplier of capacitance as a function of ambient temperature

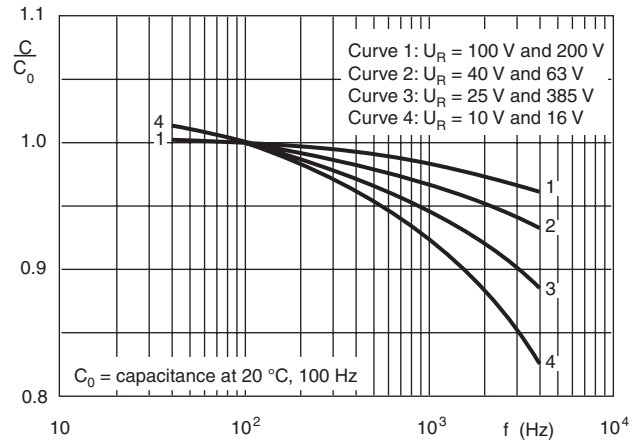


Fig.11 Typical multiplier of capacitance as a function of frequency

EQUIVALENT SERIES RESISTANCE (ESR)

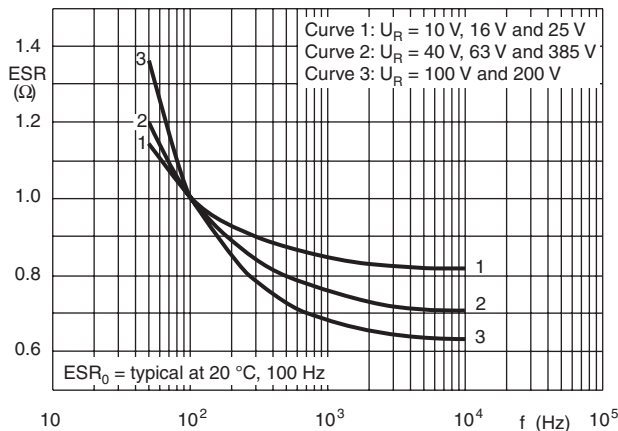


Fig.12 Typical multiplier of typical ESR as a function of frequency

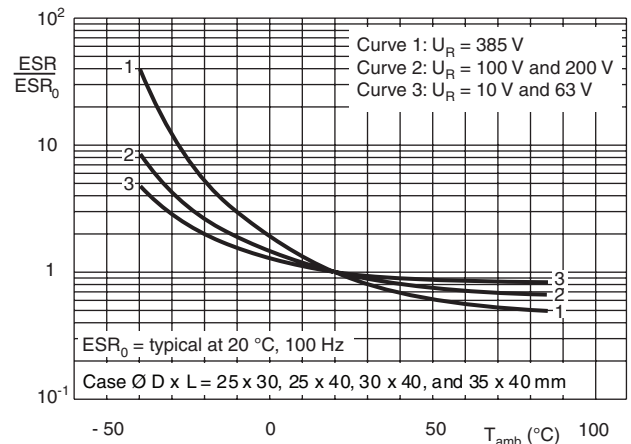


Fig.13 Typical multiplier of ESR as a function of ambient temperature



EQUIVALENT RESISTANCE (ESR)

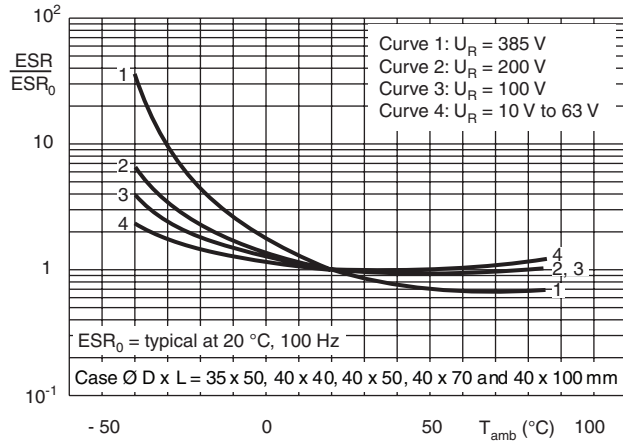


Fig.14 Typical multiplier of ESR as a function of ambient temperature

IMPEDANCE (Z)

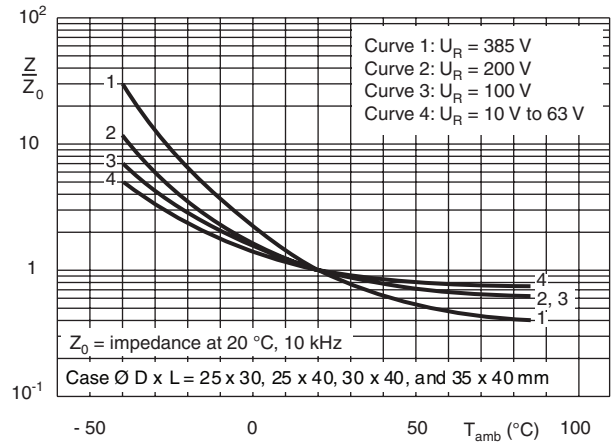


Fig.15 Typical multiplier of impedance as a function of ambient temperature

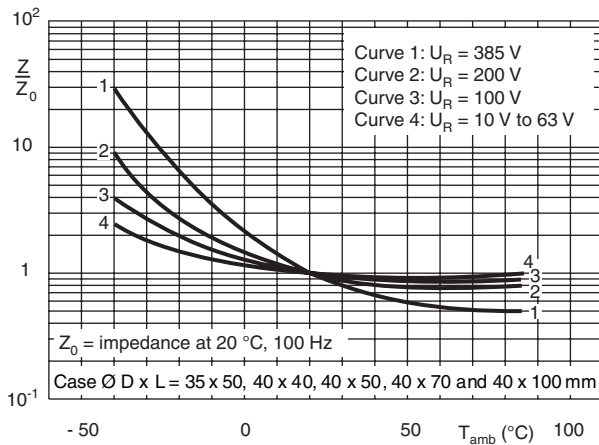


Fig.16 Typical multiplier of impedance as a function of ambient temperature

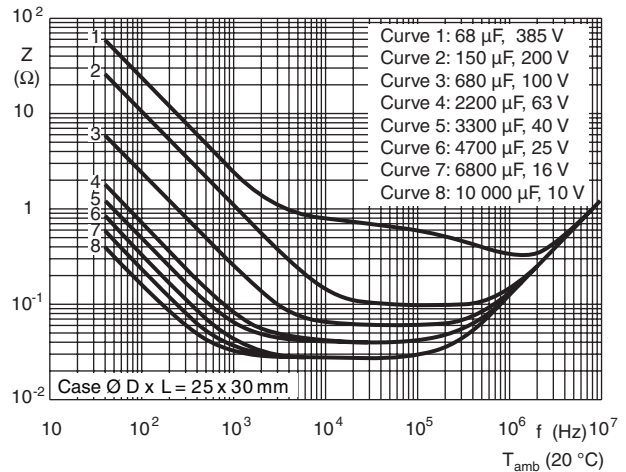


Fig.17 Typical impedance as a function of frequency

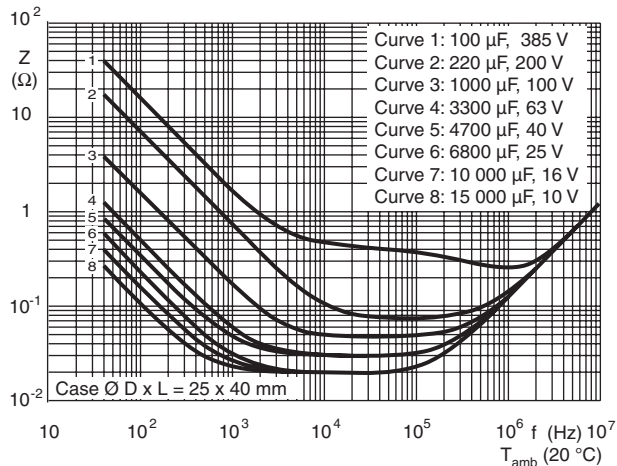


Fig.18 Typical impedance as a function of frequency

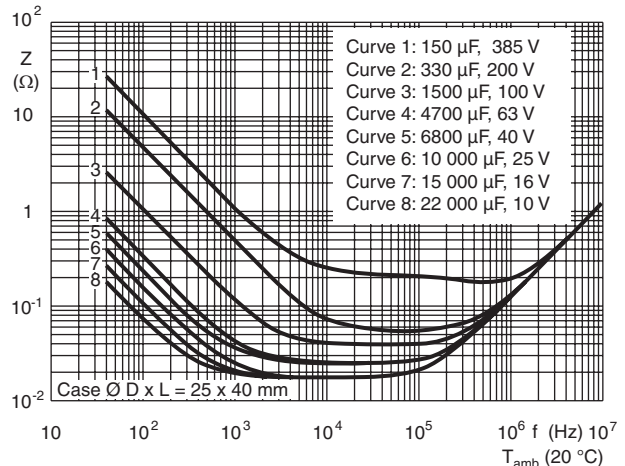


Fig.19 Typical impedance as a function of frequency



IMPEDANCE (Z)

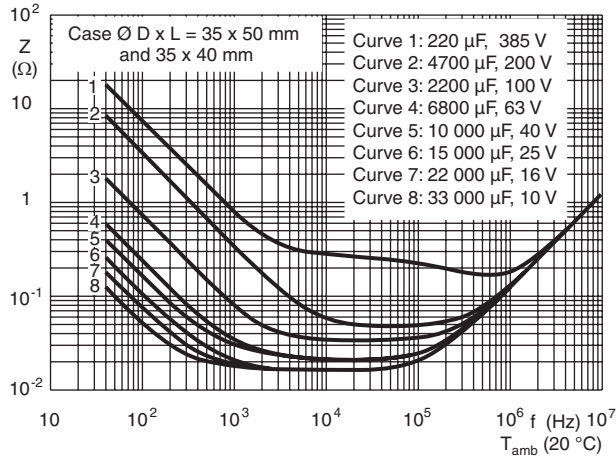


Fig.20 Typical impedance as a function of frequency

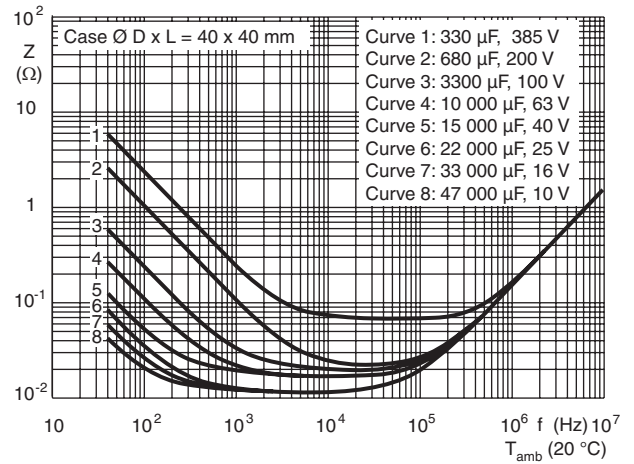


Fig.21 Typical impedance as a function of frequency

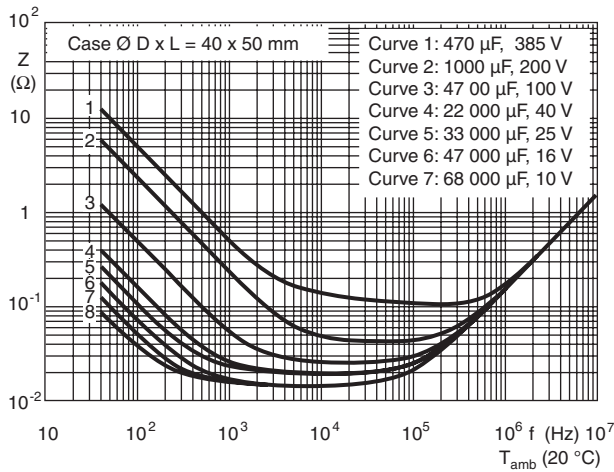


Fig.22 Typical impedance as a function of frequency

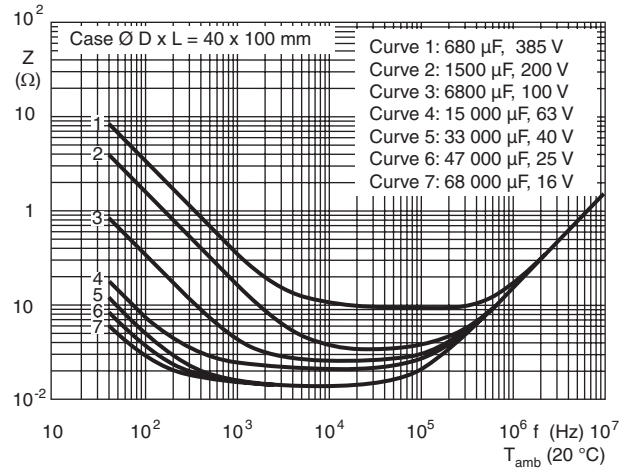


Fig.23 Typical impedance as a function of frequency

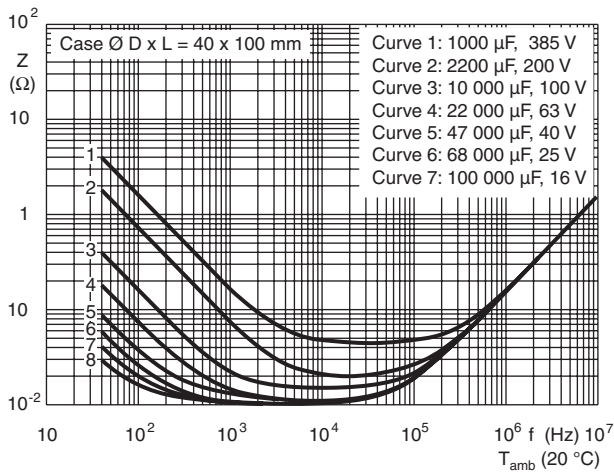
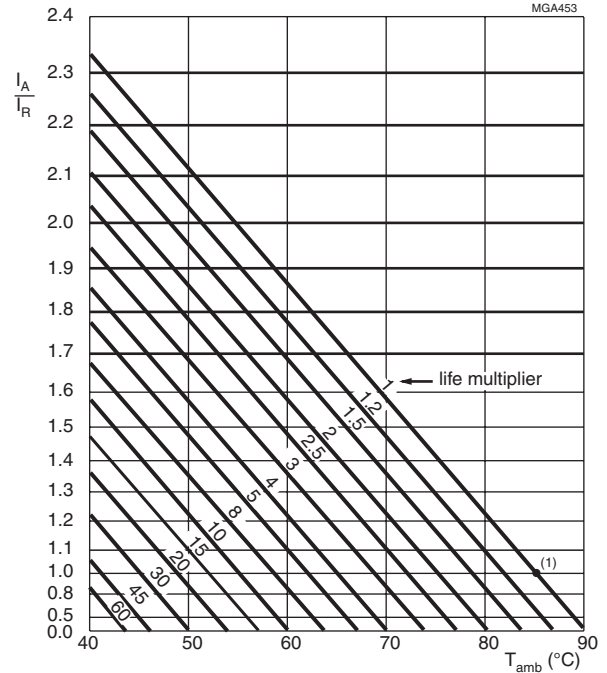


Fig.24 Typical impedance as a function of frequency

RIPPLE CURRENT AND USEFUL LIFE



I_A = actual ripple current at 100 Hz
 I_R = rated ripple current at 100 Hz and 85 °C
 (1) Useful life at 85 °C and I_R applied: 12 000 hours

Fig.25 Multiplier of useful life as a function of ambient temperature and ripple current load

Table 4

MULTIPLIER OF RIPPLE CURRENT (I_R) AS A FUNCTION OF FREQUENCY	
FREQUENCY (Hz)	I_R MULTIPLIER
50	0.83
100	1.00
200	1.10
400	1.15
1000	1.19
≥ 2000	1.20

Table 5

TEST PROCEDURES AND REQUIREMENTS			
TEST		PROCEDURE (quick reference)	REQUIREMENTS
NAME OF TEST	REFERENCE		
Endurance	IEC 60384-4/ EN130300 subclause 4.13	$T_{amb} = 85\text{ °C}$; U_R applied; 5000 hours	$U_R \leq 100\text{ V}$; $\Delta C/C: \pm 15\%$ $U_R > 100\text{ V}$; $\Delta C/C: \pm 10\%$ $ESR \leq 1.3 \times \text{spec. limit}$ $Z \leq 2 \times \text{spec. limit}$ $I_{L5} \leq \text{spec. limit}$
Useful life	CECC 30301 subclause 1.8.1	$T_{amb} = 85\text{ °C}$; U_R and I_R applied; 12 000 hours	$U_R \leq 100\text{ V}$; $\Delta C/C: \pm 45\%$ $U_R > 100\text{ V}$; $\Delta C/C: \pm 30\%$ $ESR \leq 3 \times \text{spec. limit}$ $Z \leq 3 \times \text{spec. limit}$ $I_{L5} \leq \text{spec. limit}$ no short or open circuit, no visible damage total failure percentage: $U_R \leq 100\text{ V}: \leq 1\%$; $U_R > 100\text{ V}: \leq 3\%$
Shelf life (storage at high temperature)	IEC 60384-4/ EN130300 subclause 4.17	$T_{amb} = 85\text{ °C}$; no voltage applied; 500 hours after test: U_R to be applied for 30 minutes, 24 hours to 48 hours before measurement	$\Delta C/C: \pm 10\%$ $ESR \leq 1.2 \times \text{spec. limit}$ $I_{L5} \leq 2 \times \text{spec. limit}$

Aluminum Capacitors Power Long Life 4-Terminal Snap-In

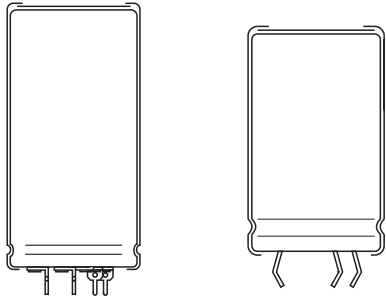
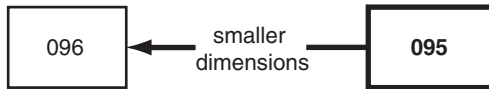


Fig.1 Component outlines



QUICK REFERENCE DATA	
DESCRIPTION	VALUE
Nominal case size (D x L in mm)	35 x 50 to 45 x 100
Rated capacitance range C_R	390 μF to 2200 μF
Tolerance on C_R	$\pm 20\%$
Rated voltage range, U_R	350 V to 450 V
Category temperature range	- 40 °C to + 85 °C
Endurance test at 85 °C	3000 hours
Useful life at 85 °C	10 000 hours
Useful life at 40 °C, 1.4 x I_R applied	400 000 hours
Shelf life at 0 V, 85 °C	1000 hours
Based on sectional specification	IEC 60384-4/EN130300
Climatic category IEC 60 068	40/085/56

FEATURES

- Polarized aluminum electrolytic capacitors, non-solid electrolyte
- Large types, minimized dimensions, cylindrical aluminum case, insulated with a blue sleeve
- Pressure relief on the side of the aluminum case
- Very long useful life: 10 000 hours at 85 °C
- Temperature range up to 85 °C
- Keyed polarity
- Low ESR, high ripple current capability


**RoHS
COMPLIANT**
APPLICATIONS

- Telecommunication and industrial systems
- Smoothing and filtering applications
- Switched mode power supplies
- Renewable energy power converters
- Energy storage in pulse systems
- For excellent mounting stability

MARKING

The capacitors are marked (where possible) with the following information:

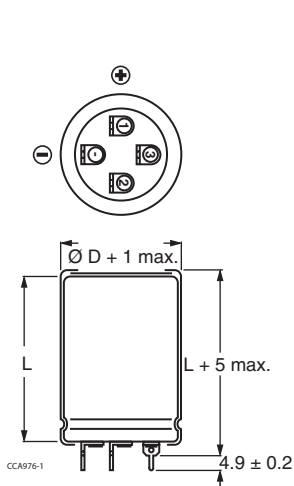
- Rated capacitance (in μF)
- Tolerance code on rated capacitance, code letter in accordance with IEC 60062 (M for $\pm 20\%$)
- Rated voltage (in V)
- Date code (YYMM)
- Name of manufacturer
- Code for factory of origin
- '-' sign to identify the negative terminal, visible from the top and side of the capacitor
- Code number
- Climatic category in accordance with IEC 60068

SELECTION CHART FOR C_R , U_R AND RELEVANT NOMINAL CASE SIZES (\varnothing D x L in mm)				
C_R (μF)	U_R (V)			
	350	400	420	450
390	-	-	-	35 x 50 40 x 40
470	-	35 x 50 40 x 40	35 x 50 40 x 40	35 x 60 40 x 50 45 x 40
560	35 x 50	35 x 60 45 x 40	35 x 60	35 x 70 40 x 60
680	35 x 60 40 x 50	35 x 70 40 x 60 45 x 50	35 x 70 40 x 60 45 x 50	35 x 80 40 x 60 45 x 50
820	35 x 70 40 x 60	35 x 80 40 x 60	35 x 80 40 x 70 45 x 50	40 x 70 45 x 60

SELECTION CHART FOR C_R , U_R AND RELEVANT NOMINAL CASE SIZES ($\varnothing D \times L$ in mm)				
C_R (μF)	U_R (V)			
	350	400	420	450
1000	35 x 80 40 x 60 45 x 50	35 x 100 40 x 70 45 x 60	35 x 100 40 x 80 45 x 60	40 x 100 45 x 70
1500	40 x 80 45 x 70	40 x 100 45 x 80	40 x 100 45 x 80	45 x 100
1800	40 x 100	45 x 100	45 x 100	-
2200	45 x 100	-	-	-

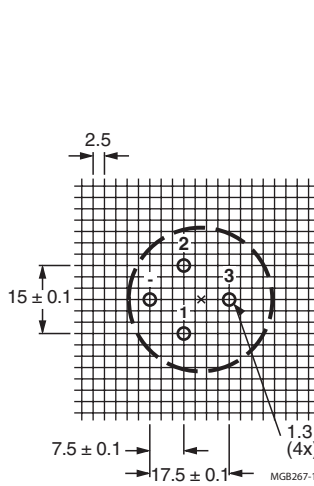
DIMENSIONS in millimeters **AND AVAILABLE FORMS**

PRINTED WIRING



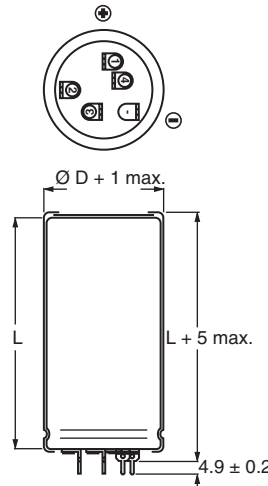
Case $\varnothing D = 35$ mm

Fig.2 Printed wiring pin version



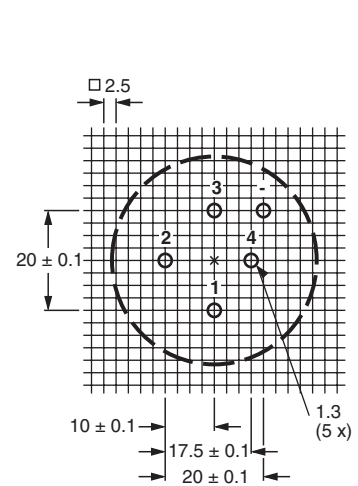
Case $\varnothing D = 35$ mm

Fig.3 Mounting hole diagram viewed from component side



Case $\varnothing D = 40$ mm

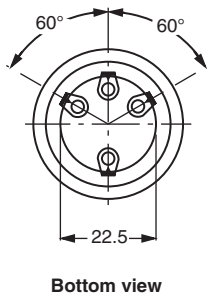
Fig.4 Printed wiring pin version



Case $\varnothing D = 40$ mm

Fig.5 Mounting hole diagram viewed from component side

FOUR TERMINAL SNAP-IN



Bottom view

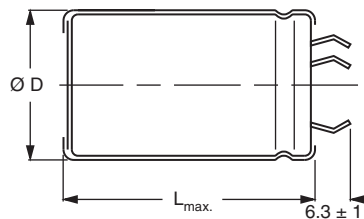
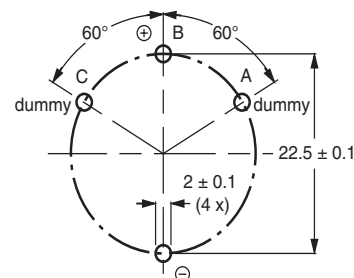


Fig.6 4-Terminal Snap-in



Dummy terminals (A and C) must be free from the electrical circuit

Fig.7 Mounting hole diagram



Table 1

DIMENSIONS in millimeters, MASS AND PACKAGING QUANTITIES						
NOMINAL CASE SIZE Ø D x L	Ø D _{max.}	4T-SI L _{max.}	PW L + 5	MASS (g)	PACKAGING QUANTITIES (units per box)	CARDBOARD BOX DIMENSIONS L x W x H
35 x 50	36	52	55	72	50	390 x 198 x 60
35 x 60	36	62	65	91	50	390 x 198 x 70
35 x 70	36	72	75	103	50	390 x 198 x 80
35 x 80	36	82	85	115	25	TBD
35 x 100	36	102	105	151	25	TBD
40 x 40	41	42	45	70	50	440 x 223 x 60
40 x 50	41	52	55	94	50	440 x 223 x 70
40 x 60	41	62	65	118	25	230 x 230 x 80
40 x 70	41	72	75	134	25	230 x 230 x 90
40 x 80	41	82	85	150	25	230 x 230 x 100
40 x 100	41	102	105	176	25	230 x 230 x 120
45 x 40	46	42	-	88	36	TBD
45 x 50	46	52	-	119	36	TBD
45 x 60	46	62	-	150	36	TBD
45 x 70	46	72	-	170	36	TBD
45 x 80	46	82	-	190	36	TBD
45 x 100	46	102	-	250	36	TBD

ELECTRICAL DATA	
SYMBOL	DESCRIPTION
C _R	rated capacitance at 100 Hz
I _R	rated RMS ripple current at 100 Hz and 85 °C
I _{L5}	max. leakage current after 5 minutes at U _R
ESR	max. equivalent series resistance at 100 Hz
Z	max. impedance at 10 kHz

Note

- Unless otherwise specified, all electrical values in table 2 apply at T_{amb} = 20 °C, P = 86 kPa to 106 kPa, RH = 45 % to 75 %

ORDERING EXAMPLE

Electrolytic capacitor 095 series
1000 µF/450 V;
Nominal case size: Ø 40 mm x 100 mm

4 terminal Snap-in:

Ordering code: MAL209527102E3

Former 12NC: 222209527102

Printed Wiring:

Ordering code: MAL209577102E3

Former 12NC: 222209577102

Table 2

ELECTRICAL DATA AND ORDERING INFORMATION								
U _R (V)	C _R 100 Hz (µF)	NOMINAL CASE SIZE Ø D x L (mm)	I _R 100 Hz 85 °C (A)	I _{L5} 5 min (µA)	ESR max. 100 Hz (mΩ)	Z max. 10 kHz (mΩ)	ORDERING CODE MAL2095.....	
							4T-SI	PW
350	560	35 x 50	3.4	396	196	120	15561E3	65561E3
	680	35 x 60	4.0	480	162	99	15681E3	65681E3
	680	40 x 50	4.1	480	165	102	25681E3	75681E3
	820	35 x 70	4.5	578	135	82	15821E3	65821E3
	820	40 x 60	4.6	578	137	85	25821E3	75821E3
	1000	35 x 80	5.1	704	112	68	15102E3	65102E3
	1000	40 x 60	5.0	704	116	73	25102E3	75102E3
	1000	45 x 50	5.0	704	121	78	35102E3	-
	1500	40 x 80	6.5	1054	79	50	25152E3	75152E3
	1500	45 x 70	6.5	1054	82	53	35152E3	-
	1800	40 x 100	7.5	1264	66	42	25182E3	75182E3
	2200	45 x 100	8.6	1544	57	37	35222E3	-

**ELECTRICAL DATA AND ORDERING INFORMATION**

U _R (V)	C _R 100 Hz (μF)	NOMINAL CASE SIZE Ø D x L (mm)	I _r 100 Hz 85 °C (A)	I _{L5} 5 min (μA)	ESR max. 100 Hz (mΩ)	Z max. 10 kHz (mΩ)	ORDERING CODE MAL2095.....	
							4T-SI	PW
400	470	35 x 50	3.2	380	215	126	16471E3	66471E3
	470	40 x 40	3.0	380	222	132	26471E3	76471E3
	560	35 x 60	3.7	452	180	105	16561E3	66561E3
	560	45 x 40	3.2	452	192	116	36561E3	-
	680	35 x 70	4.1	548	149	87	16681E3	66681E3
	680	40 x 60	4.3	548	151	89	26681E3	76681E3
	680	45 x 50	4.3	548	156	93	36681E3	-
	820	35 x 80	4.7	660	125	73	16821E3	66821E3
	820	40 x 60	4.6	660	129	77	26821E3	76821E3
	1000	35 x 100	5.9	804	102	60	16102E3	66102E3
	1000	40 x 70	5.2	804	107	64	26102E3	76102E3
	1000	45 x 60	5.4	804	110	67	36102E3	-
	1500	40 x 100	7.2	1204	72	43	26152E3	76152E3
	1500	45 x 80	6.7	1204	75	47	36152E3	-
1800	45 x 100	7.9	1444	63	38	36182E3	-	
420	470	35 x 50	3.1	399	232	141	14471E3	64471E3
	470	40 x 40	3.0	399	238	147	24471E3	74471E3
	560	35 x 60	3.6	474	194	119	14561E3	64561E3
	680	35 x 70	4.1	575	161	98	14681E3	64681E3
	680	40 x 60	4.3	575	163	100	24681E3	74681E3
	680	45 x 50	4.3	575	167	104	34681E3	-
	820	35 x 80	4.6	693	134	82	14821E3	64821E3
	820	40 x 70	4.8	693	136	84	24821E3	74821E3
	820	45 x 50	4.6	693	143	91	34821E3	-
	1000	35 x 100	5.8	844	110	67	14102E3	64102E3
	1000	40 x 80	5.4	844	112	69	24102E3	74102E3
	1000	45 x 60	5.4	844	117	75	34102E3	-
	1500	40 x 100	7.2	1264	77	48	24152E3	74152E3
	1500	45 x 80	6.7	1264	80	51	34152E3	-
1800	45 x 100	7.8	1516	67	43	34182E3	-	
450	390	35 x 50	2.9	355	246	142	17391E3	67391E3
	390	40 x 40	2.8	355	253	148	27391E3	77391E3
	470	35 x 60	3.4	427	204	118	17471E3	67471E3
	470	40 x 50	3.5	427	208	121	27471E3	77471E3
	470	45 x 40	3.0	427	217	129	37471E3	-
	560	35 x 70	3.8	508	172	99	17561E3	67561E3
	560	40 x 60	4.0	508	174	101	27561E3	77561E3
	680	35 x 80	4.3	616	143	82	17681E3	67681E3
	680	40 x 60	4.3	616	147	87	27681E3	77681E3
	680	45 x 50	4.3	616	153	91	37681E3	-
	820	40 x 70	4.8	742	123	72	27821E3	77821E3
	820	45 x 60	5.0	742	126	76	37821E3	-
	1000	40 x 100	6.0	904	99	57	27102E3	77102E3
	1000	45 x 70	5.6	904	104	63	37102E3	-
	1200	40 x 100	6.4	1084	85	50	27122E3	77122E3
	1500	45 x 100	7.4	1354	71	42	37152E3	-



ADDITIONAL ELECTRICAL DATA		
PARAMETER	CONDITIONS	VALUE
Voltage		
Surge voltage	≥ 350 V versions	$U_s = 1.1 \times U_R$
Reverse voltage		$U_{rev} \leq 1$
Current		
Leakage current	After 1 minute at U_R	$I_{L1} \leq 0.006 C_R \times U_R + 4 \mu A$
	After 5 minutes at U_R	$I_{L5} \leq 0.002 C_R \times U_R + 4 \mu A$
Inductance		
Equivalent series inductance (ESL)	All case sizes	ca. 20 nH

RIPPLE CURRENT AND USEFUL LIFE

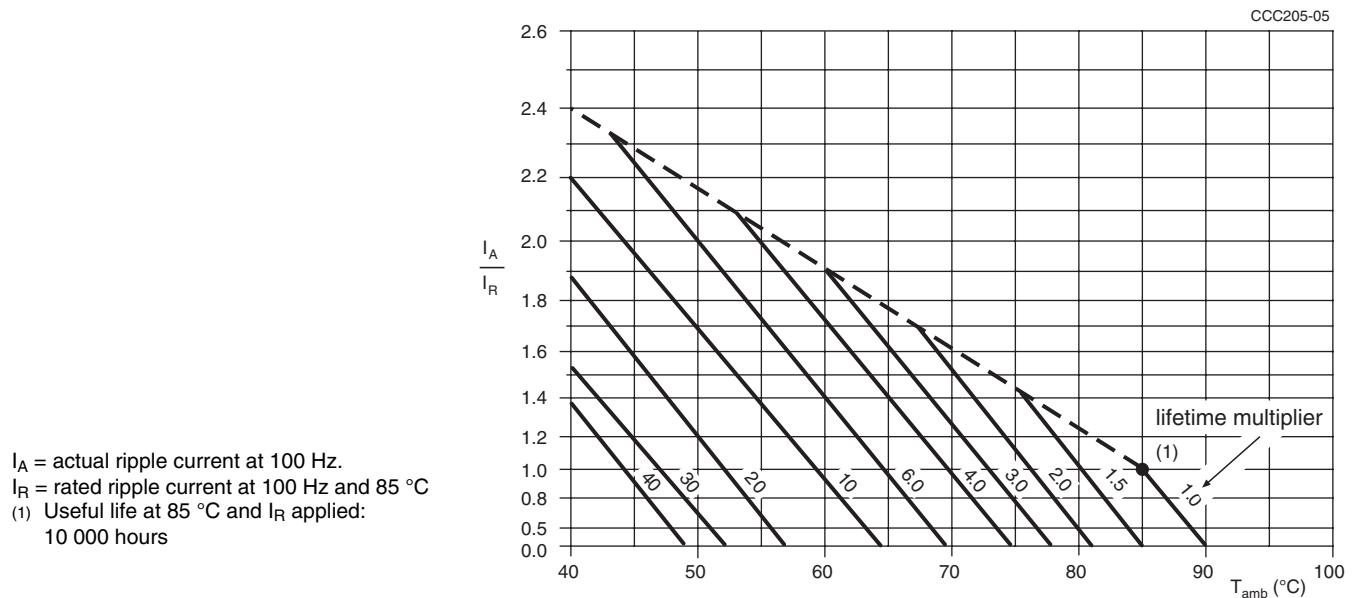


Fig.6 Multiplier of useful life as a function of ambient temperature and ripple current load

Table 3

MULTIPLIER OF RIPPLE CURRENT (I_R) AS A FUNCTION OF FREQUENCY	
FREQUENCY (Hz)	I_R MULTIPLIER
50	0.9
100	1.0
200	1.2
400	1.3
1000	1.4
10 000	1.5

Table 4

TEST PROCEDURES AND REQUIREMENTS			
TEST		PROCEDURE	REQUIREMENTS
NAME OF TEST	REFERENCE		
Endurance	IEC 60384-4/ EN130300 subclause 4.13	$T_{amb} = 85\text{ }^{\circ}\text{C}$; U_R applied; 3000 hours	$\Delta C/C: \pm 10\%$ $ESR \leq 1.3 \times \text{spec. limit}$ $Z \leq 2 \times \text{spec. limit}$ $I_{L5} \leq \text{spec. limit}$
Useful life	CECC 30301 subclause 4.13	$T_{amb} = 85\text{ }^{\circ}\text{C}$; U_R and I_R applied; 10 000 hours	$\Delta C/C: \pm 30\%$ $ESR \leq 3 \times \text{spec. limit}$ $Z \leq 3 \times \text{spec. limit}$ $I_{L5} \leq \text{spec. limit}$ no short or open circuit, no visible damage total failure percentage $\leq 3\%$
Shelf life	IEC 60384-4/ EN130300 subclause 4.17	$T_{amb} = 85\text{ }^{\circ}\text{C}$; no voltage applied; 1000 hours after test: U_R to be applied for 30 minutes 24 hours to 48 hours before measurement	$\Delta C/C: \pm 10\%$ $ESR \leq 1.2 \times \text{spec. limit}$ $I_{L5} \leq 2 \times \text{spec. limit}$

Aluminum Capacitors Power Long Life 4-Terminal Snap-In

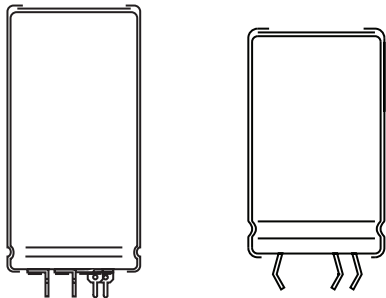
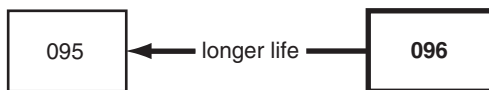


Fig.1 Component outlines



FEATURES

- Polarized aluminum electrolytic capacitors, non-solid electrolyte
- Large types, minimized dimensions, cylindrical aluminum case, insulated with a blue sleeve
- Pressure relief on the side of the aluminum case
- Very long useful life: 5000 hours at 85 °C
- Temperature range up to 85 °C
- Keyed polarity
- Low ESR, high ripple current capability


**RoHS
COMPLIANT**

APPLICATIONS

- Telecommunication and industrial systems
- Smoothing and filtering applications
- Switched mode power supplies
- Renewable energy power converters
- Energy storage in pulse systems
- For excellent mounting stability

MARKING

The capacitors are marked (where possible) with the following information:

- Rated capacitance (in μF)
- Tolerance code on rated capacitance, code letter in accordance with IEC 60062 (M for $\pm 20\%$)
- Rated voltage (in V)
- Date code (YYMM)
- Name of manufacturer
- Code for factory of origin
- ‘-’ sign to identify the negative terminal, visible from the top and side of the capacitor
- Code number
- Climatic category in accordance with IEC 60068

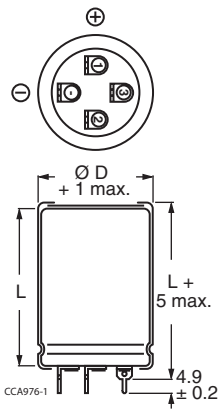
QUICK REFERENCE DATA	
DESCRIPTION	VALUE
Nominal case size (D x L in mm)	35 x 50 to 45 x 100
Rated capacitance range C_R	390 μF to 2700 μF
Tolerance on C_R	$\pm 20\%$
Rated voltage range, U_R	350 V to 500 V
Category temperature range	- 40 °C to + 85 °C
Endurance test at 85 °C	2000 hours
Useful life at 85 °C	5000 hours
Useful life at 40 °C, 1.4 x I_R applied	200 000 hours
Shelf life at 0 V, 85 °C	1000 hours
Based on sectional specification	IEC 60384-4/EN130300
Climatic category IEC 60068	40/085/56

SELECTION CHART FOR C_R , U_R AND RELEVANT NOMINAL CASE SIZES (\varnothing D x L in mm)						
C_R (μF)	U_R (V)					
	350	385	400	420	450	500
390	-	-	-	-	-	35 x 60
470	-	-	-	-	-	35 x 70
560	-	-	-	-	35 x 60	35 x 70 40 x 60
680	-	35 x 50 40 x 50	35 x 60 40 x 50	35 x 60 40 x 50	35 x 70 40 x 50	35 x 80 40 x 70
820	35 x 50 40 x 40	35 x 60 40 x 50	35 x 60 40 x 50	35 x 70 40 x 60	35 x 80 40 x 60	35 x 100 40 x 80
1000	35 x 60 40 x 50	35 x 70 40 x 60	35 x 70 40 x 60 45 x 50	35 x 80 40 x 60	35 x 100 40 x 70 45 x 60	40 x 100 45 x 70

SELECTION CHART FOR C_R , U_R AND RELEVANT NOMINAL CASE SIZES ($\varnothing D \times L$ in mm)						
C_R (μF)	U_R (V)					
	350	385	400	420	450	500
1200	35 x 70 40 x 60	35 x 80 40 x 70	35 x 80 40 x 70 45 x 60	40 x 70	40 x 80 45 x 70	45 x 100
1500	35 x 80 40 x 70 45 x 60	40 x 80 45 x 60	35 x 100 40 x 80 45 x 70	40 x 100 45 x 70	40 x 100 45 x 80	45 x 100
1800	40 x 80 45 x 60	40 x 100 45 x 70	40 x 100 45 x 80	40 x 100 45 x 80	45 x 100	-
2200	40 x 100 45 x 70	40 x 100	45 x 100	45 x 100	-	-
2700	45 x 100	45 x 100	45 x 100	-	-	-

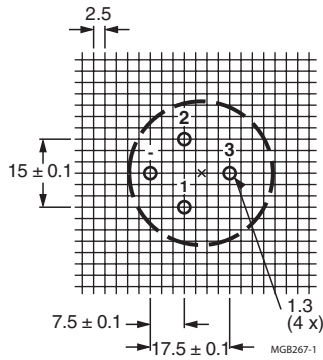
DIMENSIONS in millimeters **AND AVAILABLE FORMS**

PRINTED WIRING



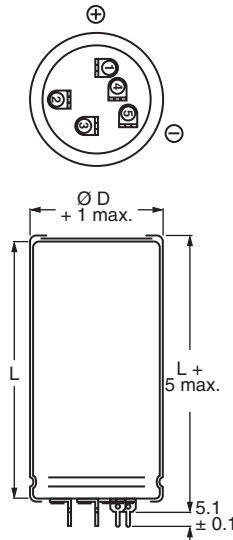
Case $\varnothing D = 35$ mm

Fig.2 Printed wiring pin version



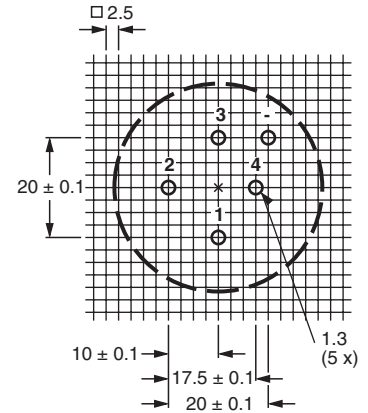
Case $\varnothing D = 35$ mm

Fig.3 Mounting hole diagram viewed from component side



Case $\varnothing D = 40$ mm

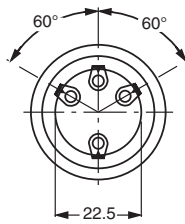
Fig.4 Printed wiring pin version



Case $\varnothing D = 40$ mm

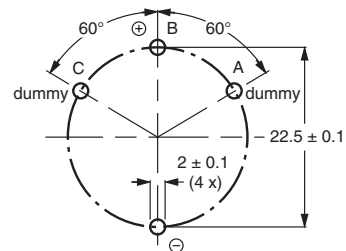
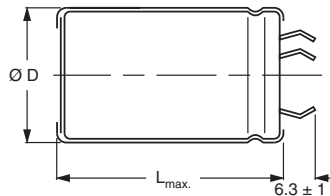
Fig.5 Mounting hole diagram viewed from component side

FOUR TERMINAL SNAP-IN



Bottom view

Fig.6 4-Terminal snap-in



Dummy terminals (A and C) must be free from the electrical circuit

Fig.7 Mounting hole diagram



Table 1

DIMENSIONS in millimeters, MASS AND PACKAGING QUANTITIES						
NOMINAL CASE SIZE Ø D x L	Ø D _{max.}	4T-SI L _{max.}	PW L+5	MASS (g)	PACKAGING QUANTITIES (units per box)	CARDBOARD BOX DIMENSIONS L x W x H
35 x 50	36	52	55	72	50	390 x 198 x 60
35 x 60	36	62	65	91	50	390 x 198 x 70
35 x 70	36	72	75	103	50	390 x 198 x 80
35 x 80	36	82	85	115	25	TBD
35 x 100	36	102	105	151	25	TBD
40 x 40	41	42	45	70	50	440 x 223 x 60
40 x 50	41	52	55	94	50	440 x 223 x 70
40 x 60	41	62	65	118	25	230 x 230 x 80
40 x 70	41	72	75	134	25	230 x 230 x 90
40 x 80	41	82	85	150	25	230 x 230 x 100
40 x 100	41	102	105	176	25	230 x 230 x 120
45 x 40	46	42	-	88	36	TBD
45 x 50	46	52	-	119	36	TBD
45 x 60	46	62	-	150	36	TBD
45 x 70	46	72	-	170	36	TBD
45 x 80	46	82	-	190	36	TBD
45 x 100	46	102	-	250	36	TBD

ELECTRICAL DATA	
SYMBOL	DESCRIPTION
C _R	rated capacitance at 100 Hz
I _R	rated RMS ripple current at 100 Hz and 85 °C
I _{L5}	max. leakage current after 5 minutes at U _R
ESR	max. equivalent series resistance at 100 Hz
Z	max. impedance at 10 kHz

Note

- Unless otherwise specified, all electrical values in table 2 apply at
T_{amb} = 20 °C, P = 86 kPa to 106 kPa, RH = 45 % to 75 %

ORDERING EXAMPLE

Electrolytic capacitor 096 series
820 µF/385 V;

Printed Wiring:

Ordering code: MAL209668821 E3

Former 12NC: 222209668821

4-Terminal Snap In:

Ordering code: MAL209618821 E3

Former 12NC: 222209618821

Table 2

ELECTRICAL DATA AND ORDERING INFORMATION								
U _R (V)	C _R 100 Hz (µF)	NOMINAL CASE SIZE Ø D x L (mm)	I _R 100 Hz 85 °C (A)	I _{L5} 5 min (µA)	ESR 100 Hz (mΩ)	Z max. 10 kHz (mΩ)	CATALOG NUMBER MAL2096.....	
							4T-SI	PW
350	820	35 x 50	4.0	578	126	82	15821E3	65821E3
	820	40 x 40	3.8	578	134	90	25821E3	75821E3
	1000	35 x 60	4.7	704	104	67	15102E3	65102E3
	1000	40 x 50	4.8	704	108	72	25102E3	75102E3
	1200	35 x 70	5.3	844	87	57	15122E3	65122E3
	1200	40 x 60	5.4	844	90	59	25122E3	75122E3
	1500	35 x 80	6.0	1054	71	47	15152E3	65152E3
	1500	40 x 70	6.2	1054	73	49	25152E3	75152E3
	1500	45 x 60	6.3	1054	76	52	35152E3	-
	1800	40 x 80	6.9	1264	62	41	25182E3	75182E3
	1800	45 x 60	6.6	1264	68	48	35182E3	-
	2200	40 x 100	8.2	1544	51	34	25222E3	75222E3
	2200	45 x 70	7.4	1544	57	41	35222E3	-
	2700	45 x 100	9.2	1894	44	30	35272E3	-

**ELECTRICAL DATA AND ORDERING INFORMATION**

U _R (V)	C _R 100 Hz (μF)	NOMINAL CASE SIZE Ø D x L (mm)	I _R 100 Hz 85 °C (A)	I _{L5} 5 min (μA)	ESR 100 Hz (mΩ)	Z max. 10 kHz (mΩ)	CATALOG NUMBER MAL2096.....	
							4T-SI	PW
385	680	35 x 50	3.7	528	140	88	18681E3	68681E3
	680	40 x 50	4.2	528	140	87	28681E3	78681E3
	820	35 x 60	4.4	635	116	73	18821E3	68821E3
	820	40 x 50	4.5	635	120	76	28821E3	78821E3
	1000	35 x 70	5.0	774	96	60	18102E3	68102E3
	1000	40 x 60	5.1	774	99	63	28102E3	78102E3
	1200	35 x 80	5.5	928	81	51	18122E3	68122E3
	1200	40 x 70	5.7	928	83	53	28122E3	78122E3
	1500	40 x 80	6.5	1159	68	43	28152E3	78152E3
	1500	45 x 60	6.2	1159	74	50	38152E3	-
	1800	40 x 100	7.7	1390	56	36	28182E3	78182E3
	1800	45 x 70	7.0	1390	62	43	38182E3	-
	2200	40 x 100	8.2	1698	49	32	28222E3	78222E3
	2700	45 x 100	9.1	2083	43	29	38272E3	-
400	680	35 x 60	4.1	548	134	82	16681E3	66681E3
	680	40 x 50	4.2	548	138	85	26681E3	76681E3
	820	35 x 60	4.4	660	114	71	16821E3	66821E3
	820	40 x 50	4.5	660	119	75	26821E3	76821E3
	1000	35 x 70	5.0	804	94	59	16102E3	66102E3
	1000	40 x 60	5.1	804	97	62	26102E3	76102E3
	1000	45 x 50	5.1	804	103	67	36102E3	-
	1200	35 x 80	5.5	964	80	50	16122E3	66122E3
	1200	40 x 70	5.7	964	82	52	26122E3	76122E3
	1200	45 x 60	5.9	964	85	55	36122E3	-
	1500	35 x 100	7.1	1204	64	40	16152E3	66152E3
	1500	40 x 80	6.5	1204	67	43	26152E3	76152E3
	1500	45 x 70	6.6	1204	69	46	36152E3	-
	1800	40 x 100	7.7	1444	56	35	26182E3	76182E3
1800	45 x 80	7.3	1444	59	39	36182E3	-	
2200	45 x 100	8.6	1764	48	32	36222E3	-	
2700	45 x 100	9.1	2164	42	29	36272E3	-	
420	680	35 x 60	4.1	575	137	85	14681E3	64681E3
	680	40 x 50	4.2	575	141	89	24681E3	74681E3
	820	35 x 70	4.6	693	114	71	14821E3	64821E3
	820	40 x 60	4.7	693	117	74	24821E3	74821E3
	1000	35 x 80	5.1	844	95	59	14102E3	64102E3
	1000	40 x 60	5.1	844	100	64	24102E3	74102E3
	1200	40 x 70	5.7	1012	84	54	24122E3	74122E3
	1500	40 x 100	7.2	1264	66	42	24152E3	74152E3
	1500	45 x 70	6.6	1264	71	48	34152E3	-
	1800	40 x 100	7.6	1516	57	37	24182E3	74182E3
	1800	45 x 80	7.2	1516	60	40	34182E3	-
2200	45 x 100	8.5	1852	49	33	34222E3	-	



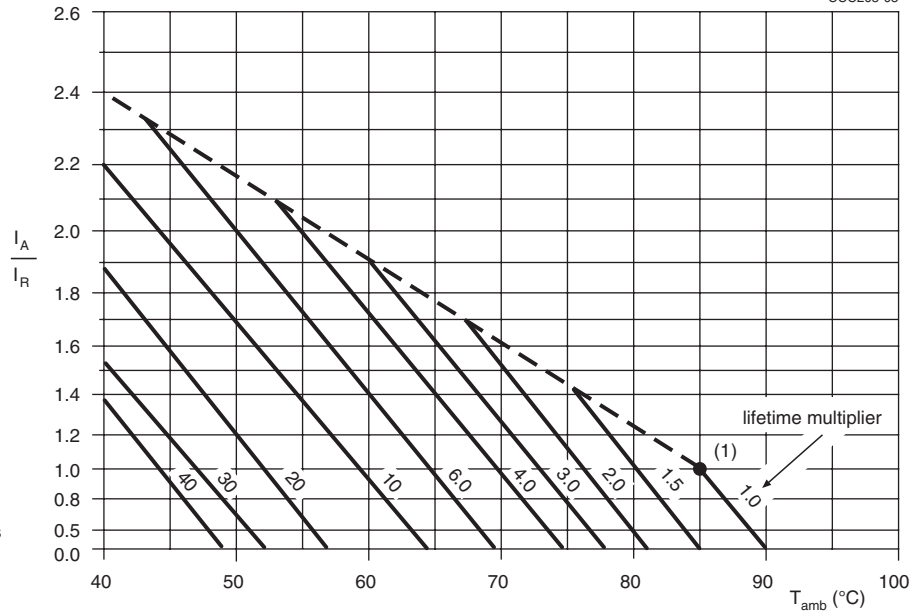
ELECTRICAL DATA AND ORDERING INFORMATION								
U _R (V)	C _R 100 Hz (μF)	NOMINAL CASE SIZE Ø D x L (mm)	I _R 100 Hz 85 °C (A)	I _{L5} 5 min (μA)	ESR 100 Hz (mΩ)	Z max. 10 kHz (mΩ)	CATALOG NUMBER MAL2096.....	
							4T-SI	PW
450	560	35 x 60	3.8	508	155	94	17561E3	67561E3
	680	35 x 70	4.2	616	129	78	17681E3	67681E3
	680	40 x 50	4.2	616	136	85	27681E3	77681E3
	820	35 x 80	4.8	742	108	66	17821E3	67821E3
	820	40 x 60	4.7	742	112	70	27821E3	77821E3
	1000	35 x 100	6.0	904	89	54	17102E3	67102E3
	1000	40 x 70	5.3	904	93	58	27102E3	77102E3
	1000	45 x 60	5.5	904	97	62	37102E3	-
	1200	40 x 80	6.0	1084	78	49	27122E3	77122E3
	1200	45 x 70	6.1	1084	81	52	37122E3	-
	1500	40 x 100	7.2	1354	63	39	27152E3	77152E3
	1500	45 x 80	6.8	1354	67	43	37152E3	-
	1800	45 x 100	8.0	1624	55	35	37182E3	-
500	390	35 x 60	2.9	394	475	421	19391E3	69391E3
	470	35 x 70	3.3	474	395	350	19471E3	69471E3
	560	35 x 70	3.6	564	333	296	19561E3	69561E3
	560	40 x 60	3.7	564	336	299	29561E3	79561E3
	680	35 x 80	4.1	684	275	245	19681E3	69681E3
	680	40 x 70	4.2	684	277	247	29681E3	79681E3
	820	35 x 100	5.1	824	229	203	19821E3	69821E3
	820	40 x 80	4.7	824	231	206	29821E3	79821E3
	1000	40 x 100	5.6	1004	189	169	29102E3	79102E3
	1000	45 x 70	5.3	1004	195	176	39102E3	-
	1200	45 x 100	6.4	1204	160	144	39122E3	-
	1500	45 x 100	7.0	1504	131	118	39152E3	-

ADDITIONAL ELECTRICAL DATA		
PARAMETER	CONDITIONS	VALUE
Voltage		
Surge voltage	≥ 350 V versions	U _s = 1.1 x U _R
Reverse voltage		U _{rev} ≤ 1
Current		
Leakage current	After 1 minute at U _R	I _{L1} ≤ 0.006 C _R x U _R + 4 μA
	After 5 minutes at U _R	I _{L5} ≤ 0.002 C _R x U _R + 4 μA
Inductance		
Equivalent series inductance (ESL)	All case sizes	ca. 20 nH



RIPPLE CURRENT AND USEFUL LIFE

CCC205-05



I_A = actual ripple current at 100 Hz.
 I_R = rated ripple current at 100 Hz and 85 °C
 (1) Useful life at 85 °C and I_R applied: 5000 hours

Fig.8 Multiplier of useful life as a function of ambient temperature and ripple current load

Table 3

MULTIPLIER OF RIPPLE CURRENT (I_R) AS A FUNCTION OF FREQUENCY	
FREQUENCY (Hz)	I_R MULTIPLIER
50	0.9
100	1.0
200	1.2
400	1.3
1000	1.4
10 000	1.5

Table 4

TEST PROCEDURES AND REQUIREMENTS			
TEST		PROCEDURE (quick reference)	REQUIREMENTS
NAME OF TEST	REFERENCE		
Endurance	IEC 60384-4/ EN130300 subclause 4.13	$T_{amb} = 85\text{ °C}$; U_R applied 2000 hours	$\Delta C/C: \pm 10\%$ ESR $\leq 1.3 \times$ spec. limit $Z \leq 2 \times$ spec. limit $I_{L5} \leq$ spec. limit
Useful life	CECC 30301 subclause 4.13	$T_{amb} = 85\text{ °C}$; U_R and I_R applied; 5000 hours	$\Delta C/C: \pm 30\%$ ESR $\leq 3 \times$ spec. limit $Z \leq 3 \times$ spec. limit $I_{L5} \leq$ spec. limit no short or open circuit, no visible damage total failure percentage: $\leq 3\%$
Shelf life	IEC 60384-4/ EN130300 subclause 4.17	$T_{amb} = 85\text{ °C}$; no voltage applied; 1000 hours After test: U_R to be applied for 30 minutes 24 hours to 48 hours before measurement	$\Delta C/C: \pm 10\%$ ESR $\leq 1.2 \times$ spec. limit $I_{L5} \leq 2 \times$ spec. limit

Aluminum Capacitors Power Long Life Printed Wiring

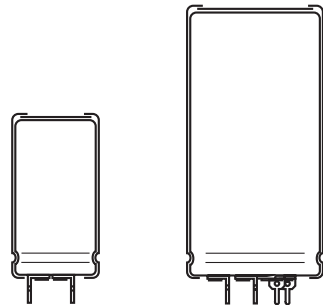
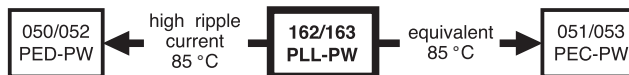


Fig.1 Component outlines



QUICK REFERENCE DATA		
DESCRIPTION	VALUE	
	162	163
Nominal case size (Ø D x L in mm)	25 x 30 to 40 x 100	
Rated capacitance range (E6 series), C _R	470 µF to 150 000 µF	68 µF to 3300 µF
Tolerance on C _R	± 20 %	
Rated voltage range, U _R	10 V to 100 V	200 V to 400 V
Category temperature range	- 40 °C to + 105 °C	
Endurance test at 105 °C	2000 hours	
Useful life at 105 °C	5000 hours	
Useful life at 40 °C, 1.9 x I _R applied	150 000 hours	
Shelf life at 0 V, 105 °C	500 hours	
Based on sectional specification	IEC 60384-4/EN130300	
Climatic category IEC 60068	40/105/56	

FEATURES

- Polarized aluminum electrolytic capacitors, non-solid electrolyte
- Large types, minimized dimensions, cylindrical aluminum case, insulated with a blue sleeve
- Provided with keyed polarity
- Very long useful life: 5000 hours at 105 °C
- Low ESR, high ripple current capability
- Temperature range up to 105 °C
- High resistance to shock and vibration


**RoHS
COMPLIANT**
APPLICATIONS

- Computer, telecommunication and industrial systems
- Smoothing and filtering
- Standard and switched mode power supplies
- Energy storage in pulse systems

MARKING

The capacitors are marked (where possible) with the following information:

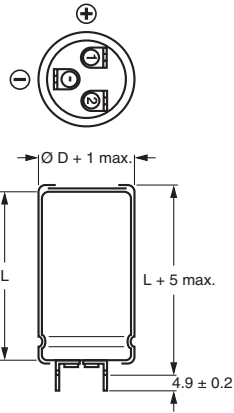
- Rated capacitance (in µF)
- Tolerance on rated capacitance, code letter in accordance with IEC 60062 (M for ± 20 %)
- Rated voltage (in V)
- Date code (YYMM)
- Name of manufacturer
- Code for factory of origin
- Polarity of the terminals and '-' sign to indicate the negative terminal, visible from the top and/or side of the capacitor
- Code number
- Climatic category in accordance with IEC 60068

SELECTION CHART FOR C _R , U _R AND RELEVANT NOMINAL CASE SIZES FOR 162 SERIES (Ø D x L in mm)						
C _R (µF)	U _R (V)					
	10	16	25	40	63	100
470	-	-	-	-	-	25 x 30
680	-	-	-	-	-	25 x 40
1000	-	-	-	-	25 x 30	30 x 40
1500	-	-	-	-	25 x 40	35 x 40
2200	-	-	-	25 x 30	30 x 40	35 x 50
3300	-	-	-	-	-	40 x 40
4700	-	-	25 x 30	25 x 40	35 x 40	40 x 50
6800	-	-	25 x 30	30 x 40	35 x 50	40 x 70
10 000	25 x 30	25 x 40	25 x 40	30 x 40	35 x 50	40 x 100
15 000	-	-	-	40 x 40	40 x 70	-
22 000	25 x 40	30 x 40	35 x 40	40 x 50	40 x 100	-
33 000	30 x 40	35 x 40	35 x 50	40 x 70	-	-
47 000	-	-	40 x 40	40 x 40	-	-
68 000	35 x 40	35 x 50	40 x 50	40 x 100	-	-
100 000	40 x 40	40 x 40	-	-	-	-
150 000	35 x 50	40 x 50	40 x 70	-	-	-
	40 x 40	-	-	-	-	-
	40 x 50	40 x 50	40 x 70	-	-	-
	40 x 50	40 x 70	40 x 100	-	-	-
	40 x 70	40 x 100	-	-	-	-
	40 x 100	-	-	-	-	-

SELECTION CHART FOR C_R , U_R AND RELEVANT NOMINAL CASE SIZES FOR 163 SERIES ($\varnothing D \times L$ in mm)

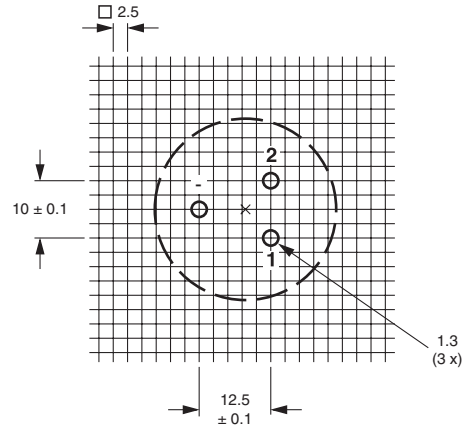
C_R (μF)	U_R (V)			
	200	250	385	400
68	-	-	25 x 30	25 x 30
100	-	25 x 30	25 x 40	25 x 40
150	25 x 30	25 x 40	30 x 40	30 x 40
220	25 x 40	30 x 40	35 x 40	35 x 40
330	30 x 40	35 x 40	35 x 50	35 x 50
	-	-	40 x 40	40 x 40
470	35 x 40	35 x 50	40 x 50	40 x 50
	-	40 x 40	-	-
680	35 x 50	40 x 50	40 x 70	40 x 70
	40 x 50	-	-	-
1000	40 x 50	40 x 70	40 x 100	40 x 100
1500	40 x 70	40 x 100	-	-
2200	40 x 100	-	-	-

DIMENSIONS in millimeters AND AVAILABLE FORMS



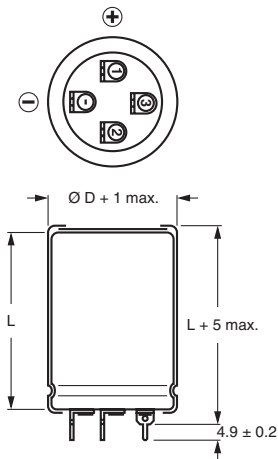
Case $\varnothing D = 25 \text{ mm}$

Fig.2 Printed wiring pin version



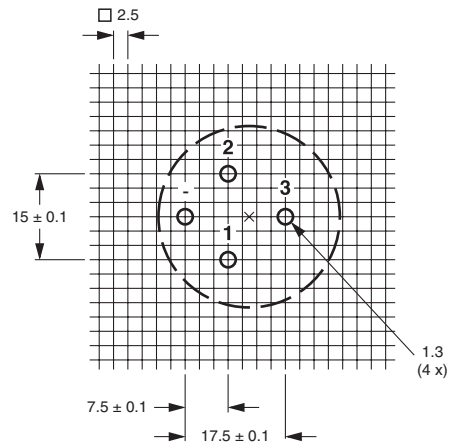
Case $\varnothing D = 25 \text{ mm}$

Fig.3 Mounting hole diagram viewed from component side



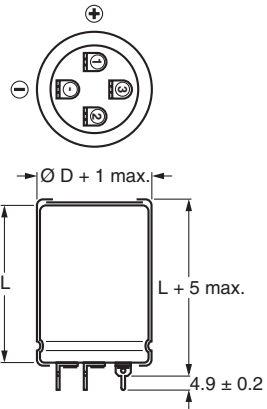
Case $\varnothing D = 30 \text{ mm}$

Fig.4 Printed wiring pin version



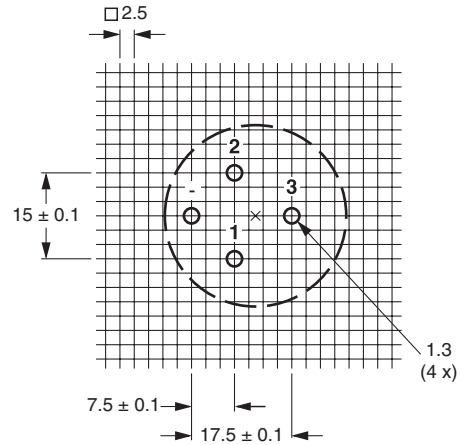
Case $\varnothing D = 30 \text{ mm}$

Fig.5 Mounting hole diagram viewed from component side



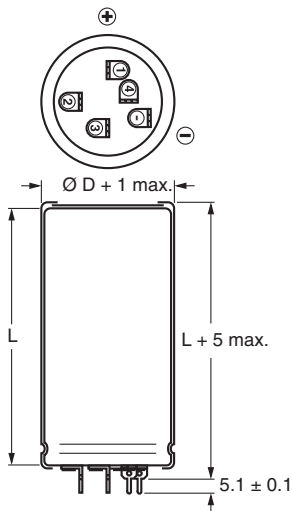
Case Ø D = 35 mm

Fig.6 Printed wiring pin version



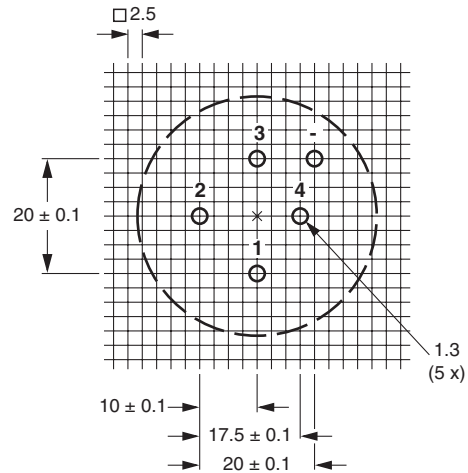
Case Ø D = 35 mm

Fig.7 Mounting hole diagram viewed from component side



Case Ø D = 40 mm

Fig.8 Printed wiring pin version



Case Ø D = 40 mm

Fig.9 Mounting hole diagram viewed from component side

Table 1

DIMENSIONS in millimeters, MASS AND PACKAGING QUANTITIES PW versions					
NOMINAL CASE SIZE Ø D x L	Ø D _{max.}	L _{max.}	MASS (g)	PACKAGING QUANTITIES (units per box)	CARDBOARD BOX DIMENSIONS L x W x H
25 x 30	26	35	≈ 24	100	290 x 280 x 50
25 x 40	26	45	≈ 28	100	290 x 280 x 60
30 x 40	31	45	≈ 38	100	340 x 330 x 60
35 x 40	36	45	≈ 51	50	390 x 198 x 60
35 x 50	36	55	≈ 66	50	390 x 198 x 70
40 x 40	41	45	≈ 78	50	440 x 223 x 60
40 x 50	41	55	≈ 82	50	440 x 223 x 70
40 x 70	41	75	≈ 110	25	230 x 230 x 90
40 x 100	41	105	≈ 176	25	230 x 230 x 120

MOUNTING

When a number of capacitors are connected in a bank, they must not be closer together than 15 mm, when no derating of ripple current and/or temperature is applied.

Pin numbers 2, 3 and 4 (if present) must be free from the electrical circuit.



ELECTRICAL DATA	
SYMBOL	DESCRIPTION
C _R	rated capacitance at 100 Hz
I _R	rated RMS ripple current at 100 Hz and 105 °C
I _{L1}	max. leakage current after 1 minute at U _R
I _{L5}	max. leakage current after 5 minutes at U _R
ESR	max. equivalent series resistance at 100 Hz
Z	max. impedance at 10 kHz

Note

- Unless otherwise specified, all electrical values in tables 2 and 3 apply at T_{amb} = 20 °C, P = 86 kPa to 106 kPa, RH = 45 % to 75 %

Table 2

ELECTRICAL DATA AND ORDERING INFORMATION FOR 162 SERIES								
U _R (V)	C _R 100 Hz (µF)	NOMINAL CASE SIZE Ø D x L (mm)	I _R 100 Hz 105 °C (A)	I _{L1} 1 min (mA)	I _{L5} 5 min (mA)	ESR 100 Hz (mΩ)	Z 10 kHz (mΩ)	ORDERING CODE MAL2162.....
10	10 000	25 x 30	3.17	0.60	0.20	48	37	54103E3
	15 000	25 x 40	4.21	0.90	0.30	34	27	54153E3
	22 000	30 x 40	5.05	1.32	0.44	29	23	54223E3
	33 000	35 x 40	5.63	1.98	0.66	27	22	54333E3
	47 000	35 x 50	6.19	2.82	0.94	26	21	54473E3
	47 000	40 x 40	6.19	2.82	0.94	26	21	44473E3
	68 000	40 x 50	7.64	4.08	1.36	21	18	54683E3
	100 000	40 x 70	10.0	6.00	2.00	16	15	54104E3
150 000	40 x 100	12.9	9.00	3.00	13	12	54154E3	
16	6800	25 x 30	3.11	0.65	0.22	50	37	55682E3
	10 000	25 x 40	4.09	0.96	0.32	36	27	55103E3
	15 000	30 x 40	4.97	1.44	0.48	30	23	55153E3
	22 000	35 x 40	5.53	2.12	0.71	29	22	55223E3
	33 000	35 x 50	6.08	3.17	1.06	28	21	55333E3
	33 000	40 x 40	6.08	3.17	1.06	28	21	45333E3
	47 000	40 x 50	7.46	4.52	1.51	22	18	55473E3
	68 000	40 x 70	9.70	6.53	2.18	17	15	55683E3
100 000	40 x 100	12.90	9.60	3.20	13	12	55104E3	
25	4700	25 x 30	2.94	0.71	0.24	56	37	56472E3
	6800	25 x 40	3.93	1.02	0.34	39	27	56682E3
	10 000	30 x 40	4.81	1.50	0.50	32	23	56103E3
	15 000	35 x 40	5.43	2.25	0.75	30	22	56153E3
	22 000	35 x 50	5.98	3.30	1.10	29	21	56223E3
	22 000	40 x 40	5.98	3.30	1.10	29	21	46223E3
	33 000	40 x 40	5.98	3.30	1.10	29	21	56533E3
	47 000	40 x 70	9.43	7.05	2.35	18	15	56473E3
68 000	40 x 100	12.44	10.20	3.40	14	12	56683E3	
40	2200	25 x 30	2.36	0.53	0.18	87	54	57222E3
	3300	25 x 40	3.17	0.79	0.27	60	38	57332E3
	4700	30 x 40	3.93	1.13	0.38	48	33	57472E3
	6800	35 x 40	4.59	1.63	0.55	42	31	57682E3
	10 000	35 x 50	5.03	2.40	0.80	41	29	57103E3
	10 000	40 x 40	5.03	2.40	0.80	41	29	47103E3
	15 000	40 x 50	6.09	3.60	1.20	33	24	57153E3
	22 000	40 x 70	8.34	5.28	1.76	23	18	57223E3
33 000	40 x 100	10.97	7.92	2.64	18	15	57333E3	
63	1000	25 x 30	1.55	0.38	0.13	202	155	58102E3
	1500	25 x 40	2.10	0.57	0.19	137	109	58152E3
	2200	30 x 40	2.72	0.83	0.28	100	79	58222E3
	3300	35 x 40	3.44	1.25	0.42	75	61	58332E3
	4700	35 x 50	4.09	1.78	0.60	62	53	58472E3
	4700	40 x 40	4.09	1.78	0.60	62	53	48472E3
	6800	40 x 50	5.10	2.57	0.86	47	40	58682E3
	10 000	40 x 70	6.86	3.78	1.26	34	29	58103E3
15 000	40 x 100	9.31	5.67	1.89	25	21	58153E3	
100	470	25 x 30	1.42	0.28	0.10	240	155	59471E3
	680	25 x 40	1.90	0.41	0.14	167	109	59681E3
	1000	30 x 40	2.48	0.60	0.20	120	79	59102E3
	1500	35 x 40	3.17	0.90	0.30	88	61	59152E3
	2200	35 x 50	3.79	1.32	0.44	72	53	59222E3
	2200	40 x 40	3.79	1.32	0.44	72	53	49222E3
	3300	40 x 50	4.81	1.98	0.66	53	40	59332E3
	4700	40 x 70	6.49	2.82	0.94	38	29	59472E3
6800	40 x 100	8.80	4.08	1.36	28	21	59682E3	

ORDERING EXAMPLE

Electrolytic capacitor 162 series

10 000 µF/25 V; ± 20 %

Nominal case size: Ø 30 x 40 mm

Ordering code: MAL216256103E3

Former 12NC: 222216256103



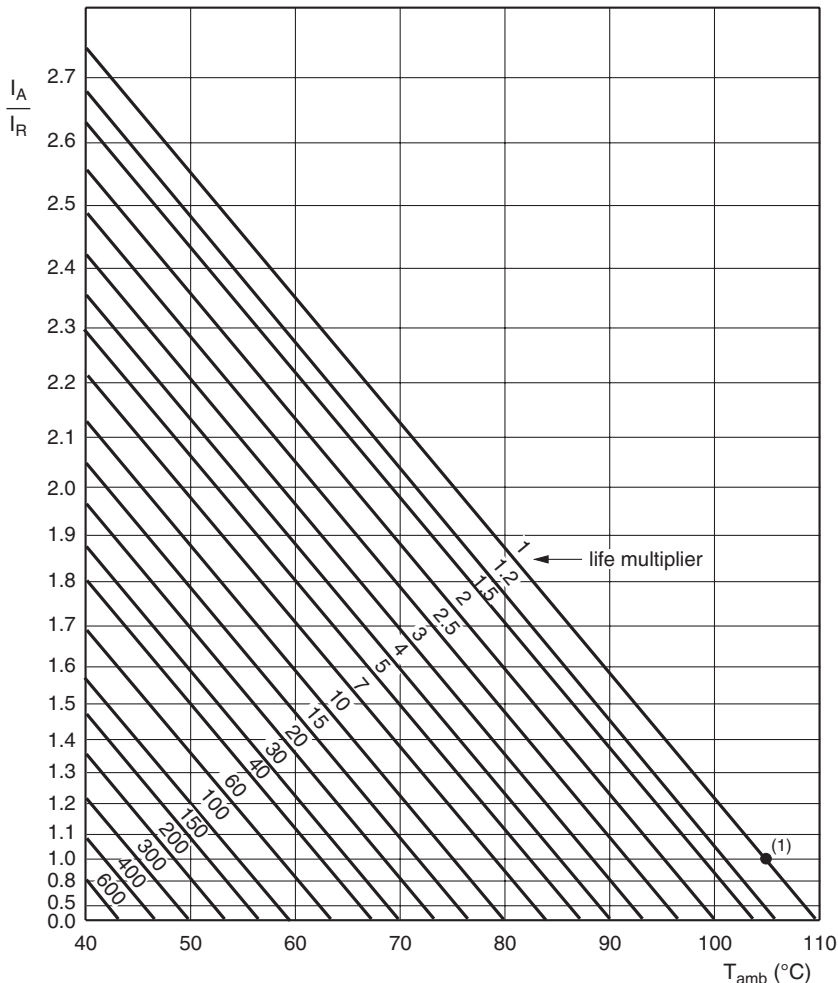
Table 3

ELECTRICAL DATA AND ORDERING INFORMATION FOR 163 SERIES								
U_R (V)	C_R 100 Hz (μ F)	NOMINAL CASE SIZE \varnothing D x L (mm)	I_R 100 Hz 105 °C (A)	I_{L1} 1 min (mA)	I_{L5} 5 min (mA)	ESR 100 Hz (m Ω)	Z 10 kHz (m Ω)	ORDERING CODE MAL2163.....
200	150	25 x 30	0.72	0.18	0.06	950	710	52151E3
	220	25 x 40	0.96	0.26	0.09	650	485	52221E3
	330	30 x 40	1.29	0.40	0.14	442	330	52331E3
	470	35 x 40	1.66	0.57	0.19	321	240	52471E3
	680	35 x 50	2.09	0.82	0.28	237	185	52681E3
	680	40 x 40	2.09	0.82	0.28	237	185	42681E3
	1000	40 x 50	2.71	1.20	0.40	167	133	52102E3
	1500	40 x 70	3.75	1.80	0.60	114	90	52152E3
2200	40 x 100	5.24	2.64	0.88	79	62	52222E3	
250	100	25 x 30	0.67	0.15	0.05	1060	710	53101E3
	150	25 x 40	0.92	0.22	0.08	710	485	53151E3
	220	30 x 40	1.28	0.33	0.11	492	330	53221E3
	330	35 x 40	1.65	0.49	0.17	325	240	53331E3
	470	35 x 50	2.01	0.70	0.24	256	185	53471E3
	470	40 x 40	2.01	0.70	0.24	256	185	43471E3
	680	40 x 50	2.59	1.02	0.34	182	133	53681E3
	1000	40 x 70	3.58	1.50	0.50	125	90	53102E3
1500	40 x 100	5.05	2.25	0.75	85	62	53152E3	
385	68	25 x 30	0.61	0.16	0.06	1650	1260	58689E3
	100	25 x 40	0.82	0.23	0.08	1120	855	58101E3
	150	30 x 40	1.10	0.35	0.12	755	580	58151E3
	220	35 x 40	1.44	0.51	0.17	525	405	58221E3
	330	35 x 50	1.84	0.77	0.26	360	280	58331E3
	330	40 x 40	1.84	0.77	0.26	360	280	48331E3
	470	40 x 50	2.37	1.09	0.36	260	205	58471E3
	680	40 x 70	3.24	1.58	0.53	180	140	58681E3
1000	40 x 100	4.54	2.31	0.78	125	100	58102E3	
400	68	25 x 30	0.39	0.16	0.06	3200	2660	56689E3
	100	25 x 40	0.53	0.24	0.08	2180	1810	56101E3
	150	30 x 40	0.72	0.36	0.12	1460	1210	56151E3
	220	35 x 40	0.94	0.52	0.17	1010	830	56221E3
	330	35 x 50	1.24	0.79	0.26	680	570	56331E3
	330	40 x 40	1.24	0.79	0.26	680	570	46331E3
	470	40 x 50	1.59	1.12	0.37	485	407	56471E3
	680	40 x 70	2.18	1.63	0.54	336	282	56681E3
1000	40 x 100	3.07	2.40	0.80	230	193	56102E3	

ADDITIONAL ELECTRICAL DATA		
PARAMETER	CONDITIONS	VALUE
Voltage		
Surge voltage	≤ 200 V versions	$U_s = 1.15 \times U_R$
	≥ 385 V versions	$U_s = 1.1 \times U_R$
Reverse voltage		$U_{rev} \leq 1$ V
Current		
Leakage current	After 1 minute at U_R	$I_{L1} \leq 0.006 C_R \times U_R + 4 \mu$ A
	After 5 minutes at U_R	$I_{L5} \leq 0.002 C_R \times U_R + 4 \mu$ A
Inductance		
Equivalent series inductance (ESL)	Case \varnothing D = 25 mm	max. 25 nH
	Case \varnothing D = 30 and 35 mm	max. 30 nH
	Case \varnothing D = 40 mm	max. 35 nH



RIPPLE CURRENT AND USEFUL LIFE



I_A = actual ripple current at 100 Hz
 I_R = rated ripple current at 100 Hz and 105 °C
 (1) Useful life at 105 °C and I_R applied: 5000 hours

Fig.10 Multiplier of useful life as a function of ambient temperature and ripple current load

Table 4

MULTIPLIER OF RIPPLE CURRENT (I_R) AS A FUNCTION OF FREQUENCY			
FREQUENCY (Hz)	I_R MULTIPLIER		
	$U_R = 10\text{ V to }25\text{ V}$	$U_R = 40\text{ V to }100\text{ V}$	$U_R = 200\text{ V to }400\text{ V}$
50	0.93	0.91	0.86
100	1.00	1.00	1.00
200	1.04	1.05	1.13
400	1.07	1.09	1.21
1000	1.11	1.13	1.29
2000	1.13	1.15	1.32
4000	1.15	1.18	1.35
≥ 10 000	1.18	1.22	1.40



Table 5

TEST PROCEDURES AND REQUIREMENT			
TEST		PROCEDURE (quick reference)	REQUIREMENTS
NAME OF TEST	REFERENCE		
Endurance	IEC 60384-4/ EN130300 subclause 4.13	$T_{amb} = 105\text{ }^{\circ}\text{C}$; U_R applied; 2000 hours	$U_R \leq 100\text{ V}$; $\Delta C/C: \pm 15\%$ $U_R > 100\text{ V}$; $\Delta C/C: \pm 10\%$ $ESR \leq 1.3 \times \text{spec. limit}$ $Z \leq 2 \times \text{spec. limit}$ $I_{L5} \leq \text{spec. limit}$
Useful life	CECC 30301 subclause 1.8.1	$T_{amb} = 105\text{ }^{\circ}\text{C}$; U_R and I_R applied; 5000 hours	$U_R \leq 100\text{ V}$; $\Delta C/C: \pm 45\%$ $U_R > 100\text{ V}$; $\Delta C/C: \pm 30\%$ $ESR \leq 3 \times \text{spec. limit}$ $Z \leq 3 \times \text{spec. limit}$ $I_{L5} \leq \text{spec. limit}$ no short or open circuit, no visible damage total failure percentage: $U_R \leq 100\text{ V}: \leq 1\%$; $U_R > 100\text{ V}: \leq 3\%$
Shelf life (storage at high temperature)	IEC 60384-4/ EN130300 subclause 4.17	$T_{amb} = 105\text{ }^{\circ}\text{C}$; no voltage applied; 500 hours After test: U_R to be applied for 30 minutes, 24 hours to 48 hours before measurement	$\Delta C/C: \pm 10\%$ $ESR \leq 1.2 \times \text{spec. limit}$ $I_{L5} \leq 2 \times \text{spec. limit}$

Aluminum Capacitors Power General Purpose Screw Terminals

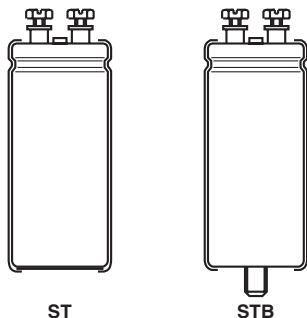


Fig.1 Component outline

RoHS
COMPLIANT

FEATURES

- Polarized aluminum electrolytic capacitors, non-solid electrolyte
- Large types, cylindrical aluminum case, insulated with a blue sleeve
- Pressure relief in the sealing disc
- Efficient design

APPLICATIONS

- UPS
- Energy storage in medical or industrial pulse systems

MARKING

The capacitors are marked with the following information:

- Rated capacitance (in μF)
- Tolerance on rated capacitance, code letter in accordance with IEC 60062 (M for $\pm 20\%$)
- Rated voltage (in V)
- Date code
- Name of manufacturer
- Code for factory of origin
- Code number

QUICK REFERENCE DATA

DESCRIPTION	VALUE
	500
Nominal case size (\varnothing D x L in mm)	50 x 80 to 90 x 220
Rated capacitance range, C_R	1000 μF to 15 000 μF
Tolerance on C_R	$\pm 20\%$
Rated voltage range, U_R	400 V to 450 V
Category temperature range	- 40 °C to + 85 °C
Endurance test at 85 °C	2000 hours
Useful life at 85 °C	2000 hours
Shelf life at 0 V, 85 °C	500 hours
Based on sectional specification	IEC 60384-4/EN 130300
Climatic category IEC 60068	40/085/56

SELECTION CHART FOR C_R , U_R AND RELEVANT NOMINAL CASE SIZES (\varnothing D x L in mm)

C_R (μF)	U_R (V)		
	400	420	450
1000	50 x 80	50 x 80	50 x 80
1200	50 x 80	50 x 80	50 x 80
1500	50 x 105	50 x 105	50 x 105
1800	50 x 105	50 x 105	50 x 105
2200	50 x 105 65 x 105	65 x 105	65 x 105
2700	65 x 105	65 x 105	65 x 105
3300	65 x 105	65 x 105	76 x 105
3900	65 x 105	76 x 105	76 x 105
4700	76 x 105	76 x 114	76 x 114
5600	76 x 114	76 x 130	76 x 146
6800	76 x 146	76 x 146	90 x 146
8200	90 x 146	90 x 146	76 x 220
10 000	76 x 220 90 x 146	76 x 220	76 x 220
12 000	76 x 220	-	90 x 220
15 000	90 x 220	90 x 220	-

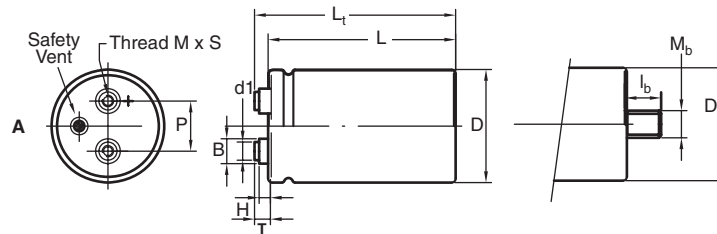
DIMENSIONS in millimeters AND AVAILABLE FORMS


Fig. 2A: Standard M5 disc: screw terminal (ST) and screw terminal bolt nut (STB)

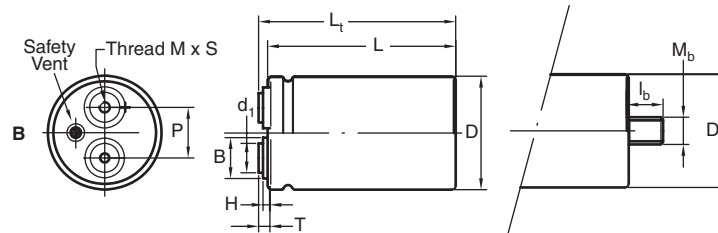


Fig. 2B: High current M6 disc: screw terminal (ST) and screw terminal bolt nut (STB)

Maximum permissible torque which may be applied to the termination screws: 2 Nm for M5; 2.5 Nm for M6
 For accessories refer to datasheet "Mounting Accessories".
 The capacitors are delivered with screws and washers.

Table 1

DIMENSIONS in millimeters, MASS AND PACKAGING QUANTITIES

DESIGN	DRAWING	L ± 1	L _t ± 1	D ± 1	P ± 0.3	T ± 0.2	H ± 0.3	B ± 0.3	d ₁ ± 0.1	M	S - 0	M _b	I _b ± 0.1	MASS (g)	PACKAGING QUANTITIES
50 x 80	2A	82.8	88.8	51.0	22.2	7.1	4.8	11.0	7.9	M5	9.5	M12	16.0	200	25
50 x 105	2A	104.8	110.8	51.0	22.2	7.1	4.8	11.0	7.9	M5	9.5	M12	16.0	300	25
65 x 105	2A	104.8	110.7	65.0	28.5	7.0	4.6	11.9	7.9	M5	9.5	M12	16.0	480	16
65 x 105 HC	2B	104.8	109.2	65.0	28.5	5.5	3.5	18.0	13.0	M6	8.5	M12	16.0	480	16
76 x 105	2A	105.8	111.7	76.4	31.8	7.0	4.6	11.7	7.9	M5	9.5	M12	16.0	700	12
76 x 105 HC	2B	105.8	110.2	76.4	31.8	5.5	3.5	18.3	13.0	M6	8.5	M12	16.0	700	12
76 x 114	2A	115.8	121.7	76.4	31.8	7.0	4.6	11.7	7.9	M5	9.5	M12	16.0	800	12
76 x 114 HC	2B	115.8	120.2	76.4	31.8	5.5	3.5	18.3	13.0	M6	8.5	M12	16.0	800	12
76 x 146	2A	145.8	151.7	76.4	31.8	7.0	4.6	11.7	7.9	M5	9.5	M12	16.0	1000	12
76 x 146 HC	2B	145.8	150.2	76.4	31.8	5.5	3.5	18.3	13.0	M6	8.5	M12	16.0	1000	12
76 x 220	2A	219.8	225.7	76.4	31.8	7.0	4.6	11.7	7.9	M5	9.5	M12	16.0	1500	10
76 x 220 HC	2B	219.8	224.2	76.4	31.8	5.5	3.5	18.3	13.0	M6	8.5	M12	16.0	1500	10
90 x 146 HC	2B	150.1	155.4	89.4	31.8	7.9	0.0	13.0	13.0	M6	10.0	M12	16.0	1300	10
90 x 220 HC	2B	218.1	223.4	89.4	31.8	7.9	0.0	13.0	13.0	M6	10.0	M12	16.0	2000	10

Note

- For bolt version holds:
 - L = L standard - 0.5 mm
 - L_t = L_t standard - 0.5 mm

ELECTRICAL DATA	
SYMBOL	DESCRIPTION
C _R	rated capacitance at 100 Hz, tolerance ± 20 %
I _R	rated RMS ripple current at 100 Hz, 85 °C
I _{L5}	max. leakage current after 5 minutes at U _R
ESR	max. equivalent series resistance at 100 Hz
Z	max. impedance at 10 kHz

Note

- Unless otherwise specified, all electrical values in tables 2 and 3 apply at T_{amb} = 20 °C, P = 86 kPa to 106 kPa, RH = 45 % to 75 %

ORDERING EXAMPLE

Electrolytic capacitor 500 series
 4700 µF/400 V; ± 20 %
 Nominal case size: Ø 76 x 105 mm;
 STB version; high post M5 disc
 Ordering code: MAL250056472E3
 Former 12NC: 222250056472

Table 2

ELECTRICAL DATA AND ORDERING INFORMATION											
U _R (V)	C _R 100 Hz (µF)	NOMINAL CASE SIZE Ø D x L (mm)	I _R 120 Hz 85 °C (A)	I _R 120 Hz 40 °C (A)	I _{L5} 5 min (mA)	ESR max. 120 Hz (mΩ)	Z max. 10 kHz (mΩ)	HIGH POST M5 DISC		HIGH CURRENT M6 DISC	
								ORDERING CODE ST MAL2500.....	ORDERING CODE STB MAL2500.....	ORDERING CODE ST MAL2500.....	ORDERING CODE STB MAL2500.....
400	1000	50 x 80	4.2	11.2	0.80	125	98	26102E3	66102E3	-	-
	1200	50 x 80	4.5	12.0	0.96	107	85	16122E3	56122E3	-	-
	1500	50 x 105	5.1	14.1	1.20	86	68	16152E3	56152E3	-	-
	1800	50 x 105	5.6	15.1	1.44	73	59	16182E3	56182E3	-	-
	2200	50 x 105	6.3	17.1	1.76	58	46	16222E3	56222E3	-	-
	2200	65 x 105	7.4	19.9	1.76	58	46	26222E3	66222E3	46222E3	86222E3
	2700	65 x 105	7.9	21.5	2.16	49	39	16272E3	56272E3	36272E3	76272E3
	3300	65 x 105	8.9	24.0	2.64	39	31	16332E3	56332E3	36332E3	76332E3
	3900	65 x 105	9.4	25.5	3.12	34	28	16392E3	56392E3	36392E3	76392E3
	4700	76 x 105	11.1	30.0	3.76	30	25	16472E3	56472E3	36472E3	76472E3
	5600	76 x 114	12.1	32.6	4.48	26	21	16562E3	56562E3	36562E3	76562E3
	6800	76 x 146	13.6	36.6	5.44	21	18	16682E3	56682E3	36682E3	76682E3
	8200	90 x 146	17.7	47.7	6.56	16	13	-	-	36822E3	76822E3
	10 000	76 x 220	17.0	45.8	8.00	15	12	16103E3	56103E3	36103E3	76103E3
	10 000	90 x 146	19.3	52.2	8.00	13	11	-	-	46103E3	86103E3
	12 000	76 x 220	17.8	48.1	9.60	13	11	16123E3	56123E3	36123E3	76123E3
15 000	90 x 220	23.6	63.7	12.00	9	8	-	-	36153E3	76153E3	
420	1000	50 x 80	4.3	11.5	0.84	105	74	14102E3	54102E3	-	-
	1200	50 x 80	4.6	12.4	1.01	90	65	14122E3	54122E3	-	-
	1500	50 x 105	5.3	14.4	1.26	72	52	14152E3	54152E3	-	-
	1800	50 x 105	5.7	15.3	1.52	62	46	14182E3	54182E3	-	-
	2200	65 x 105	7.5	20.4	1.85	49	35	14222E3	54222E3	34222E3	74222E3
	2700	65 x 105	8.1	21.9	2.27	42	31	14272E3	54272E3	34272E3	74272E3
	3300	65 x 105	9.1	24.6	2.78	33	24	14332E3	54332E3	34332E3	74332E3
	3900	76 x 105	10.7	28.8	3.28	29	22	14392E3	54392E3	34392E3	74392E3
	4700	76 x 114	11.7	31.5	3.95	25	19	14472E3	54472E3	34472E3	74472E3
	5600	76 x 130	12.8	34.6	4.71	21	16	14562E3	54562E3	34562E3	74562E3
	6800	76 x 146	13.8	37.2	5.72	18	14	14682E3	54682E3	34682E3	74682E3
	8200	90 x 146	17.6	47.6	6.89	14	10	-	-	34822E3	74822E3
	10 000	76 x 220	17.3	46.6	8.40	13	10	14103E3	54103E3	34103E3	74103E3
15 000	90 x 220	24.1	65.0	12.60	8	6	-	-	34153E3	74153E3	
450	1000	50 x 80	4.2	11.3	0.90	126	88	17102E3	57102E3	-	-
	1200	50 x 80	4.5	12.1	1.08	100	76	17122E3	57122E3	-	-
	1500	50 x 105	5.3	14.2	1.35	79	61	17152E3	57152E3	-	-
	1800	50 x 105	5.9	15.9	1.62	64	48	17182E3	57182E3	-	-
	2200	65 x 105	7.4	20.0	1.98	54	41	17222E3	57222E3	37222E3	77222E3
	2700	65 x 105	8.3	22.5	2.43	43	33	17272E3	57272E3	37272E3	77272E3
	3300	76 x 105	9.9	26.8	2.97	37	28	17332E3	57332E3	37332E3	77332E3
	3900	76 x 105	10.5	28.4	3.51	32	25	17392E3	57392E3	37392E3	77392E3
	4700	76 x 114	11.5	31.0	4.23	28	22	17472E3	57472E3	37472E3	77472E3
	5600	76 x 146	12.8	34.6	5.04	23	18	17562E3	57562E3	37562E3	77562E3
	6800	90 x 146	16.6	44.8	6.12	17	13	-	-	37682E3	77682E3
	8200	76 x 220	16.0	43.3	7.38	16	13	17822E3	57822E3	37822E3	77822E3
	10 000	76 x 220	17.0	45.8	9.00	14	11	17103E3	57103E3	37103E3	77103E3
	12 000	90 x 220	22.1	59.5	10.80	10	8	-	-	37123E3	77123E3



ADDITIONAL ELECTRICAL DATA		
PARAMETER	CONDITIONS	VALUE
Voltage		
Surge voltage	≥ 400 V versions	$U_s = 1.1 \times U_R$
Reverse voltage		$U_{rev} \leq 1 \text{ V}$
Current		
Leakage current	After 1 minute at U_R	$I_{L1} \leq 0.006 C_R \times U_R + 4 \mu\text{A}$
	After 5 minutes at U_R	$I_{L5} \leq 0.002 C_R \times U_R + 4 \mu\text{A}$
Inductance		
Equivalent series inductance (ESL)	Case Ø D = 50 mm	typ. 16 nH
	Case Ø D = 65 mm	typ. 19 nH
	Case Ø D = 76 mm	typ. 20 nH
	Case Ø D = 90 mm	typ. 20 nH

Table 3

MULTIPLIER OF RIPPLE CURRENT (I_R) AS A FUNCTION OF FREQUENCY	
FREQUENCY (Hz)	I_R MULTIPLIER
60	0.70
100	0.95
120	1.00
500	1.20
1000	1.30
≥ 10 000	1.40

Table 4

MULTIPLIER OF RIPPLE CURRENT (I_R) AS A FUNCTION OF TEMPERATURE	
TEMPERATURE (°C)	I_R MULTIPLIER
40	2.7
60	2.0
70	1.7
85	1.0

Table 5

TEST PROCEDURES AND REQUIREMENTS			
TEST		PROCEDURE (quick reference)	REQUIREMENTS
NAME OF TEST	REFERENCE		
Endurance	IEC 60384-4/ EN130300 subclause 4.13	$T_{amb} = 85 \text{ °C}$; U_R applied; 2000 hours	$\Delta C/C: \pm 10 \%$ $ESR \leq 1.3 \times \text{spec. limit}$ $Z \leq 2 \times \text{spec. limit}$ $I_{L5} \leq \text{spec. limit}$
Useful life	CECC 30301 subclause 1.8.1	$T_{amb} = 85 \text{ °C}$; U_R and I_R applied; 2000 hours	$\Delta C/C: \pm 30 \%$ $ESR \leq 3 \times \text{spec. limit}$ $Z \leq 3 \times \text{spec. limit}$ $I_{L5} \leq \text{spec. limit}$ no short or open circuit, no visible damage total failure percentage: $\leq 3 \%$
Shelf life (storage at high temperature)	IEC 60384-4/ EN130300 subclause 4.17	$T_{amb} = 85 \text{ °C}$; no voltage applied; 500 hours After test: U_R to be applied for 30 minutes, 24 hours to 48 hours before measurement	$\Delta C/C: \pm 10 \%$ $ESR \leq 1.2 \times \text{spec. limit}$ $I_{L5} \leq 2 \times \text{spec. limit}$

Aluminum Capacitors

Power High Ripple Current Screw Terminals

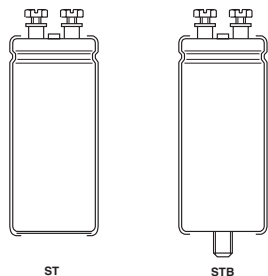


Fig. 1 Component outline

QUICK REFERENCE DATA		
DESCRIPTION	VALUE	
	101	102
Nominal case size (Ø D x L in mm)	35 x 60 to 90 x 220	
Rated capacitance range (E6 series), C _R	220 µF to 1 F	
Tolerance on C _R	± 20 %	
Rated voltage range, U _R	25 V to 100 V	200 V to 450 V
Category temperature range	- 40 °C to + 85 °C	
Endurance test at 85 °C	2000 h	
Useful life at 85 °C	10 000 h (D ≤ 50 mm) 15 000 h (D ≥ 65 mm)	10 000 h
Useful life at 40 °C, 1.4 x I _R applied	400 000 h (D ≤ 50 mm) 600 000 h (D ≥ 65 mm)	400 000 h
Shelf life at 0 V, 85 °C	500 h	
Based on sectional specification	IEC 60384-4/EN130300	
Climatic category IEC 60068	40/085/56	

FEATURES

- Polarized aluminum electrolytic capacitors, non-solid electrolyte
- Large types, cylindrical aluminum case, insulated with a blue sleeve
- Pressure relief in the sealing
- Long useful life

RoHS
COMPLIANT

APPLICATIONS

- Computer, telecom, medical, and industrial systems
- Smoothing and filtering
- Standard and switched mode power supplies

MARKING

The capacitors are marked with the following information:

- Rated capacitance (in µF)
- Tolerance on rated capacitance, code letter in accordance with IEC 60062 (M for ± 20 %)
- Rated voltage (in V)
- Date code (YYMM)
- Name of manufacturer
- Code for factory of origin
- '-' sign to identify the negative terminal, visible from the top and side of the capacitor
- Code number
- Climatic category in accordance with IEC 60068

SELECTION CHART FOR C_R, U_R AND RELEVANT NOMINAL CASE SIZES (Ø D x L in mm)

C _R (µF)	U _R (V)									
	25	40	63	100	200	250	350	385	400	450
220	-	-	-	-	-	-	-	35 x 60	35 x 60	35 x 60
330	-	-	-	-	-	-	35 x 60	-	35 x 60	-
470	-	-	-	-	-	35 x 60	-	35 x 80	35 x 80	-
680	-	-	-	-	35 x 60	35 x 80	-	-	35 x 105	-
1000	-	-	-	-	35 x 80	35 x 80	-	50 x 80	50 x 80	50 x 80
1500	-	-	-	-	35 x 105	35 x 105	-	-	-	50 x 105
2200	-	-	-	35 x 60	50 x 80	50 x 80	50 x 105	-	-	65 x 105
3300	-	-	-	35 x 60	50 x 80	50 x 105	-	-	65 x 105	-
4700	-	-	35 x 60	35 x 80	50 x 105	65 x 105	65 x 105	76 x 105	-	76 x 146
5600	-	-	-	35 x 105	65 x 105	76 x 105	76 x 146	76 x 146	76 x 146	-
6800	-	-	35 x 60	35 x 105	65 x 105	76 x 105	-	-	76 x 146	76 x 220
	-	-	35 x 80	50 x 80	76 x 105	76 x 146	76 x 146	76 x 146	-	90 x 146

SELECTION CHART FOR C_R, U_R AND RELEVANT NOMINAL CASE SIZES ($\varnothing D \times L$ in mm)										
C_R (μF)	U_R (V)									
	25	40	63	100	200	250	350	385	400	450
10 000	-	35 x 60	35 x 80	50 x 80	76 x 105	76 x 105	76 x 220	-	-	-
	-	-	35 x 105	50 x 105	76 x 146	76 x 146	90 x 146	-	-	90 x 220
15 000	35 x 60	35 x 60	35 x 105	50 x 105	76 x 146	76 x 146	-	-	-	-
	-	35 x 80	50 x 80	-	-	-	90 x 220	-	-	-
22 000	35 x 60	35 x 80	50 x 80	65 x 105	76 x 220	76 x 220	-	-	-	-
	-	50 x 80	50 x 105	76 x 105	90 x 146	90 x 146	-	-	-	-
33 000	35 x 80	35 x 105	50 x 105	76 x 105	-	-	-	-	-	-
	50 x 80	50 x 80	65 x 105	76 x 146	90 x 220	90 x 220	-	-	-	-
47 000	35 x 105	50 x 80	65 x 105	-	-	-	-	-	-	-
	50 x 80	50 x 105	76 x 105	76 x 146	-	-	-	-	-	-
68 000	50 x 80	50 x 105	76 x 105	76 x 146	-	-	-	-	-	-
	50 x 105	65 x 105	76 x 146	-	-	-	-	-	-	-
100 000	50 x 105	65 x 105	-	76 x 220	-	-	-	-	-	-
	65 x 105	76 x 105	76 x 146	90 x 146	-	-	-	-	-	-
150 000	65 x 105	76 x 105	76 x 146	-	-	-	-	-	-	-
	76 x 105	76 x 146	-	90 x 220	-	-	-	-	-	-
220 000	65 x 105	-	76 x 220	-	-	-	-	-	-	-
	76 x 105	76 x 146	90 x 146	-	-	-	-	-	-	-
330 000	76 x 146	76 x 220	-	-	-	-	-	-	-	-
	-	90 x 146	90 x 220	-	-	-	-	-	-	-
470 000	76 x 220	-	-	-	-	-	-	-	-	-
	90 x 146	90 x 220	-	-	-	-	-	-	-	-
680 000	76 x 220	-	-	-	-	-	-	-	-	-
1 000 000	90 x 220	-	-	-	-	-	-	-	-	-

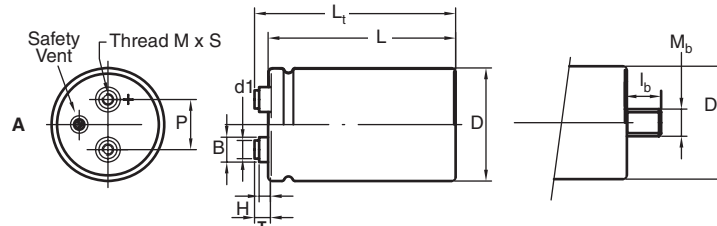
DIMENSIONS in millimeters AND AVAILABLE FORMS


Fig. 2A: Standard M5 disc: screw terminal (ST) and screw terminal bolt nut (STB)

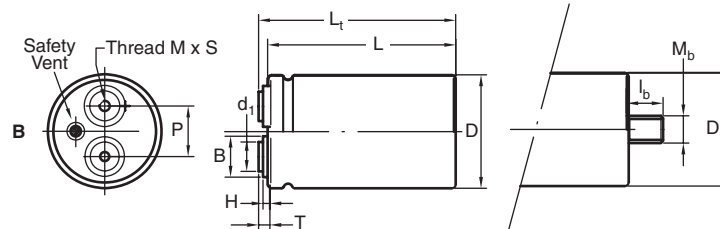


Fig. 2B: High current M6 disc: screw terminal (ST) and screw terminal bolt nut (STB)

Maximum permissible torque which may be applied to the termination screws: 2 Nm for M5; 2.5 Nm for M6
 For accessories refer to datasheet "Mounting Accessories".
 The capacitors are delivered with screws and washers.

Table 1

DIMENSIONS in millimeters, MASS AND PACKAGING QUANTITIES															
DESIGN	DRAWING	L ± 1	L _t ± 1	D ± 1	P ± 0.3	T ± 0.2	H ± 0.3	B ± 0.3	d ₁ ± 0.1	M	S - 0	Mb	l _b ± 0.1	MASS (g)	PACKAGING QUANTITIES
35 x 60	2A	63.3	68.7	35.3	12.8	7.0	4.6	11.0	7.9	M5	9.5	M8	12.0	75	50
35 x 80	2A	81.3	86.7	35.3	12.8	7.0	4.6	11.0	7.9	M5	9.5	M8	12.0	95	50
35 x 105	2A	103.3	108.7	35.3	12.8	7.0	4.6	11.0	7.9	M5	9.5	M8	12.0	130	50
50 x 80	2A	82.8	88.8	51.0	22.2	7.1	4.8	11.0	7.9	M5	9.5	M12	16.0	200	25
50 x 105	2A	104.8	110.8	51.0	22.2	7.1	4.8	11.0	7.9	M5	9.5	M12	16.0	300	25
65 x 105	2A	104.8	110.7	65.0	28.5	7.0	4.6	11.9	7.9	M5	9.5	M12	16.0	480	16
65 x 105 HC	2B	104.8	109.2	65.0	28.5	5.5	3.5	18.0	13.0	M6	8.5	M12	16.0	480	16
76 x 105	2A	105.8	111.7	76.4	31.8	7.0	4.6	11.7	7.9	M5	9.5	M12	16.0	700	12
76 x 105 HC	2B	105.8	110.2	76.4	31.8	5.5	3.5	18.3	13.0	M6	8.5	M12	16.0	700	12
76 x 114	2A	115.8	121.7	76.4	31.8	7.0	4.6	11.7	7.9	M5	9.5	M12	16.0	800	12
76 x 114 HC	2B	115.8	120.2	76.4	31.8	5.5	3.5	18.3	13.0	M6	8.5	M12	16.0	800	12
76 x 146	2A	145.8	151.7	76.4	31.8	7.0	4.6	11.7	7.9	M5	9.5	M12	16.0	1000	12
76 x 146 HC	2B	145.8	150.2	76.4	31.8	5.5	3.5	18.3	13.0	M6	8.5	M12	16.0	1000	12
76 x 220	2A	219.8	225.7	76.4	31.8	7.0	4.6	11.7	7.9	M5	9.5	M12	16.0	1500	10
76 x 220 HC	2B	219.8	224.2	76.4	31.8	5.5	3.5	18.3	13.0	M6	8.5	M12	16.0	1500	10
90 x 146 HC	2B	150.1	155.4	89.4	31.8	7.9	0.0	13.0	13.0	M6	10.0	M12	16.0	1300	10
90 x 220 HC	2B	218.1	223.4	89.4	31.8	7.9	0.0	13.0	13.0	M6	10.0	M12	16.0	2000	10

Note

- For bolt version holds:
 1. L = L standard - 0.5 mm
 2. L_t = L_t standard - 0.5 mm

ELECTRICAL DATA	
SYMBOL	DESCRIPTION
C _R	rated capacitance at 100 Hz, tolerance ± 20 %
I _R	rated RMS ripple current at 100 Hz, 85 °C
I _{L5}	max. leakage current after 5 minutes at U _R
ESR	max. equivalent series resistance at 100 Hz
Z	max. impedance at 20 kHz

Note

- Unless otherwise specified, all electrical values in tables 2 and 3 apply at T_{amb} = 20 °C, P = 86 kPa to 106 kPa, RH = 45 % to 75 %.

ORDERING EXAMPLE

Electrolytic capacitor 101 series
10 000 µF/40 V; ± 20 %
Nominal case size: Ø 35 x 60 mm;
ST version, high post M5 disc

Ordering code: MAL210117103E3
Former 12NC: 222210117103



Aluminum Capacitors
Power High Ripple Current Screw Terminals

Vishay BCcomponents

Table 2

ELECTRICAL DATA AND ORDERING INFORMATION FOR 101 SERIES										
U _R (V)	C _R 100 Hz (μF)	NOMINAL CASE SIZE Ø D x L (mm)	I _R 100 Hz 85 °C (A)	I _{L5} 5 min (mA)	ESR max. 100 Hz (mΩ)	Z max. 20 kHz (mΩ)	STANDARD HIGH POST M5 DISC		HIGH CURRENT M6 DISC	
							ST ORDERING CODE	ST BOLT NUT ORDERING CODE	ST ORDERING CODE	ST BOLT NUT ORDERING CODE
							MAL2101.....	MAL2101.....	MAL2101.....	MAL2101.....
25	15 000	35 x 60	7.7	0.75	29	22	16153E3	56153E3	-	-
	22 000	35 x 60	8.3	1.10	27	22	16223E3	56223E3	-	-
	33 000	35 x 80	9.0	1.65	19	17	16333E3	56333E3	-	-
	33 000	50 x 80	10.0	1.65	17	14	26333E3	66333E3	-	-
	47 000	35 x 105	12.1	2.35	15	13	16473E3	56473E3	-	-
	47 000	50 x 80	14.8	2.35	12	10	26473E3	66473E3	-	-
	68 000	50 x 80	12.8	3.40	15	13	16683E3	56683E3	-	-
	68 000	50 x 105	17.1	3.40	9	8	26683E3	66683E3	-	-
	100 000	50 x 105	14.7	5.00	12	11	16104E3	56104E3	-	-
	100 000	65 x 105	19.6	5.00	7	6	26104E3	66104E3	46104E3	86104E3
	150 000	65 x 105	17.6	7.50	8	7	16154E3	56154E3	36154E3	76154E3
	150 000	76 x 105	21.4	7.50	6	5	26154E3	66154E3	46154E3	86154E3
	220 000	65 x 105	20.2	11.0	6	5	16224E3	56224E3	36224E3	76224E3
	220 000	76 x 105	22.5	11.0	6	5	26224E3	66224E3	46224E3	86224E3
	330 000	76 x 146	25.8	16.5	4	4	26334E3	66334E3	46334E3	86334E3
	470 000	76 x 220	29.9	23.5	5	5	16474E3	56474E3	36474E3	76474E3
	470 000	90 x 146	38.2	23.5	5	5	-	-	46474E3	86474E3
680 000	76 x 220	29.0	34.0	5	5	16684E3	56684E3	36684E3	76684E3	
1 000 000	90 x 220	46.6	50.0	5	5	-	-	46105E3	86105E3	
40	10 000	35 x 60	7.1	0.80	31	23	17103E3	57103E3	-	-
	15 000	35 x 60	7.8	1.20	28	22	17153E3	57153E3	-	-
	15 000	35 x 80	8.7	1.20	22	17	27153E3	67153E3	-	-
	22 000	35 x 80	9.4	1.76	20	17	17223E3	57223E3	-	-
	22 000	50 x 80	11.2	1.76	19	15	27223E3	67223E3	-	-
	33 000	35 x 105	11.0	2.64	15	13	17333E3	57333E3	-	-
	33 000	50 x 80	13.7	2.64	13	10	27333E3	67333E3	-	-
	47 000	50 x 80	14.6	3.76	12	10	17473E3	57473E3	-	-
	47 000	50 x 105	15.9	3.76	10	8	27473E3	67473E3	-	-
	68 000	50 x 105	16.9	5.44	9	8	17683E3	57683E3	-	-
	68 000	65 x 105	18.1	5.44	7	6	27683E3	67683E3	47683E3	87683E3
	100 000	65 x 105	19.2	8.0	7	6	17104E3	57104E3	37104E3	77104E3
	100 000	76 x 105	21.3	8.0	7	6	27104E3	67104E3	47104E3	87104E3
	150 000	76 x 105	20.5	12.0	7	6	17154E3	57154E3	37154E3	77154E3
	150 000	76 x 146	24.0	12.0	5	5	27154E3	67154E3	47154E3	87154E3
	220 000	76 x 146	24.5	17.6	5	5	27224E3	67224E3	47224E3	87224E3
	330 000	76 x 220	28.2	26.4	5	5	17334E3	57334E3	37334E3	77334E3
330 000	90 x 146	38.6	26.4	5	5	-	-	47334E3	87334E3	
470 000	90 x 220	41.5	37.6	5	5	-	-	47474E3	87474E3	

ELECTRICAL DATA AND ORDERING INFORMATION FOR 101 SERIES										
U _R (V)	C _R 100 Hz (µF)	NOMINAL CASE SIZE Ø D x L (mm)	I _R 100 Hz 85 °C (A)	I _{L5} 5 min (mA)	ESR max. 100 Hz (mΩ)	Z max. 20 kHz (mΩ)	STANDARD HIGH POST		HIGH CURRENT	
							M5 DISC		M6 DISC	
							ST ORDERING CODE MAL2101.....	ST BOLT NUT ORDERING CODE MAL2101.....	ST ORDERING CODE MAL2101.....	ST BOLT NUT ORDERING CODE MAL2101.....
63	4700	35 x 60	5.9	0.59	42	25	18472E3	58472E3	-	-
	6800	35 x 60	6.6	0.86	38	25	18682E3	58682E3	-	-
	6800	35 x 80	7.3	0.86	30	19	28682E3	68682E3	-	-
	10 000	35 x 80	8.1	1.26	27	19	18103E3	58103E3	-	-
	10 000	35 x 105	8.8	1.26	22	14	28103E3	68103E3	-	-
	15 000	35 x 105	9.7	1.89	19	14	18153E3	58153E3	-	-
	15 000	50 x 80	12.1	1.89	16	11	28153E3	68153E3	-	-
	22 000	50 x 80	11.1	2.77	19	15	18223E3	58223E3	-	-
	22 000	50 x 105	14.3	2.77	12	9	28223E3	68223E3	-	-
	33 000	50 x 105	12.9	4.16	14	12	18333E3	58333E3	-	-
	33 000	65 x 105	16.5	4.16	9	6	28333E3	68333E3	48333E3	88333E3
	47 000	65 x 105	15.6	5.92	10	8	18473E3	58473E3	38473E3	78473E3
	47 000	76 x 105	18.6	5.92	8	6	28473E3	68473E3	48473E3	88473E3
	68 000	76 x 105	20.0	8.57	7	6	18683E3	58683E3	38683E3	78683E3
	68 000	76 x 146	21.9	8.57	6	5	28683E3	68683E3	48683E3	88683E3
	100 000	76 x 146	23.4	12.6	5	5	28104E3	68104E3	48104E3	88104E3
	150 000	76 x 146	22.2	18.9	6	5	18154E3	58154E3	38154E3	78154E3
	220 000	76 x 220	27.0	27.7	5	5	18224E3	58224E3	38224E3	78224E3
	220 000	90 x 146	36.5	27.7	5	5	-	-	48224E3	88224E3
	330 000	90 x 220	42.9	41.6	5	5	-	-	48334E3	88334E3
100	2200	35 x 60	5.2	0.44	50	29	19222E3	59222E3	-	-
	3300	35 x 60	6.0	0.66	42	27	19332E3	59332E3	-	-
	3300	35 x 80	6.6	0.66	35	21	29332E3	69332E3	-	-
	4700	35 x 80	7.3	0.94	31	20	19472E3	59472E3	-	-
	4700	35 x 105	7.9	0.94	26	16	29472E3	69472E3	-	-
	6800	35 x 105	8.8	1.36	23	15	19682E3	59682E3	-	-
	6800	50 x 80	10.9	1.36	19	12	29682E3	69682E3	-	-
	10 000	50 x 80	10.5	2.00	21	15	19103E3	59103E3	-	-
	10 000	50 x 105	13.1	2.00	14	9	29103E3	69103E3	-	-
	15 000	50 x 105	12.3	3.00	16	12	19153E3	59173E3	-	-
	22 000	65 x 105	14.8	4.40	11	8	19223E3	59223E3	39223E3	79223E3
	22 000	76 x 105	17.4	4.40	9	6	29223E3	69223E3	49223E3	89223E3
	33 000	76 x 105	19.0	6.60	8	6	19333E3	59333E3	39333E3	79333E3
	33 000	76 x 146	20.7	6.60	7	5	29333E3	69333E3	49333E3	89333E3
	47 000	76 x 146	22.4	9.40	6	5	29473E3	69473E3	49473E3	89473E3
	68 000	76 x 146	25.6	13.6	6	5	19683E3	59683E3	39683E3	79683E3
	100 000	76 x 220	31.2	20.0	5	5	19104E3	59104E3	39104E3	79104E3
	100 000	90 x 146	41.5	20.0	5	5	-	-	49104E3	89104E3
	150 000	90 x 220	49.1	30.0	5	5	-	-	49154E3	89154E3



Aluminum Capacitors
Power High Ripple Current Screw Terminals

Table 3

ELECTRICAL DATA AND ORDERING INFORMATION FOR 102 SERIES										
U _R (V)	C _R 100 Hz (µF)	NOMINAL CASE SIZE Ø D x L (mm)	I _R 100 Hz 85 °C (A)	I _{L5} 5 min (mA)	ESR max. 100 Hz (mΩ)	Z max. 20 kHz (mΩ)	HIGH POST M5 DISC		HIGH CURRENT M6 DISC	
							ST ORDERING CODE MAL2102.....	ST BOLT NUT ORDERING CODE MAL2102.....	ST ORDERING CODE MAL2102.....	ST BOLT NUT ORDERING CODE MAL2102.....
200	680	35 x 60	3.5	0.27	207	136	12681E3	52681E3	-	-
	1000	35 x 80	4.4	0.40	144	95	12102E3	52102E3	-	-
	1000	35 x 105	4.7	0.40	140	91	22102E3	62102E3	-	-
	1500	35 x 105	5.5	0.60	100	67	12152E3	52152E3	-	-
	1500	50 x 80	6.2	0.60	106	74	22152E3	62152E3	-	-
	2200	50 x 80	8.0	0.88	67	44	12222E3	52222E3	-	-
	3300	50 x 80	8.9	1.32	50	35	12332E3	52332E3	-	-
	3300	50 x 105	9.9	1.32	46	32	22332E3	62332E3	-	-
	4700	65 x 105	12.5	1.88	37	26	22472E3	62472E3	42472E3	82472E3
	6800	65 x 105	15.2	2.72	25	18	12682E3	52662E3	32682E3	72682E3
	6800	76 x 105	16.9	2.72	25	18	22682E3	62662E3	42682E3	82682E3
	10 000	76 x 105	19.9	4.00	18	13	12103E3	52103E3	32103E3	72103E3
	10 000	76 x 146	20.4	4.00	18	13	22103E3	62103E3	42103E3	82103E3
	15 000	76 x 146	24.1	6.00	12	9	12153E3	52153E3	32153E3	72153E3
	22 000	76 x 220	29.5	8.8	9	7	12223E3	52223E3	32223E3	72223E3
22 000	90 x 146	34.1	8.8	8	6	-	-	42223E3	82223E3	
33 000	90 x 220	41.7	13.2	6	5	-	-	42333E3	82333E3	
250	470	35 x 60	3.1	0.24	250	152	13471E3	53471E3	-	-
	680	35 x 80	3.8	0.34	175	107	13681E3	53681E3	-	-
	1000	35 x 80	4.4	0.50	128	82	13102E3	53102E3	-	-
	1000	35 x 105	4.8	0.50	122	76	23102E3	63102E3	-	-
	1500	35 x 105	5.4	0.75	90	58	13152E3	53152E3	-	-
	1500	50 x 80	7.0	0.75	81	50	23152E3	63152E3	-	-
	2200	50 x 80	8.0	1.10	60	39	13222E3	53222E3	-	-
	2200	50 x 105	8.7	1.10	57	35	23222E3	63222E3	-	-
	3300	50 x 105	9.8	1.65	42	28	13332E3	53332E3	-	-
	3300	65 x 105	11.4	1.65	42	28	23332E3	63332E3	43332E3	83332E3
	4700	65 x 105	13.8	2.35	29	19	13472E3	53472E3	33472E3	73472E3
	4700	76 x 105	15.3	2.35	29	19	23472E3	63472E3	43472E3	83472E3
	6800	76 x 105	18.1	3.40	21	14	13682E3	53682E3	33682E3	73682E3
	6800	76 x 146	18.6	3.40	21	14	23682E3	63682E3	43682E3	83682E3
	10 000	76 x 105	19.3	5.00	17	12	13103E3	53103E3	33103E3	73103E3
10 000	76 x 146	22.0	5.00	15	10	23103E3	63103E3	43103E3	83103E3	
15 000	76 x 146	23.3	7.5	12	10	13153E3	53153E3	33153E3	73153E3	
22 000	76 x 220	29.1	11.0	9	7	13223E3	53223E3	33223E3	73223E3	
22 000	90 x 146	35.3	11.0	7	5	-	-	43223E3	83223E3	
33 000	90 x 220	43.2	16.5	5	5	-	-	43333E3	83333E3	
350	330	35 x 60	2.5	0.23	435	305	15331E3	55331E3	-	-
	470	35 x 80	3.1	0.33	308	216	25471E3	65471E3	-	-
	680	35 x 105	3.8	0.48	216	152	25681E3	65681E3	-	-
	1000	50 x 80	5.6	0.70	145	102	25102E3	65102E3	-	-
	1500	50 x 80	6.5	1.05	102	74	15152E3	55152E3	-	-
	1500	50 x 105	7.0	1.05	99	70	25152E3	65152E3	-	-
	2200	50 x 105	8.0	1.54	72	52	15222E3	55222E3	-	-
	2200	65 x 105	9.3	1.54	72	52	25222E3	65222E3	45222E3	85222E3
	3300	65 x 105	11.4	2.31	48	35	25332E3	65332E3	45332E3	85332E3
	4700	76 x 105	15.0	3.29	34	25	15472E3	55472E3	35472E3	75472E3
	4700	76 x 146	15.4	3.29	34	25	25472E3	65472E3	45472E3	85472E3
	6800	76 x 146	18.3	4.76	24	18	25682E3	65682E3	45682E3	85682E3
	10 000	76 x 220	23.2	7.0	15	12	15103E3	55103E3	35103E3	75103E3
	10 000	90 x 146	25.1	7.0	15	12	-	-	45103E3	85103E3
	15 000	90 x 220	31.2	10.5	10	8	-	-	45153E3	85153E3

ELECTRICAL DATA AND ORDERING INFORMATION FOR 102 SERIES										
U _R (V)	C _R 100 Hz (μF)	NOMINAL CASE SIZE Ø D x L (mm)	I _R 100 Hz 85 °C (A)	I _{L5} 5 min (mA)	ESR max. 100 Hz (mΩ)	Z max. 20 kHz (mΩ)	HIGH POST M5 DISC		HIGH CURRENT M6 DISC	
							ST ORDERING CODE	ST BOLT NUT ORDERING CODE	ST ORDERING CODE	ST BOLT NUT ORDERING CODE
							MAL2102.....	MAL2102.....	MAL2102.....	MAL2102.....
385	220	35 x 60	2.1	0.17	575	380	18221E3	58221E3	-	-
	330	35 x 80	2.7	0.26	386	257	18331E3	58331E3	-	-
	470	35 x 80	3.1	0.37	279	188	18471E3	58471E3	-	-
	680	35 x 105	3.9	0.53	196	133	18681E3	58681E3	-	-
	1000	50 x 80	5.6	0.77	132	89	18102E3	58102E3	-	-
	1500	50 x 105	7.1	1.16	90	61	18152E3	58152E3	-	-
	2200	65 x 105	10.0	1.70	61	42	18222E3	58222E3	38222E3	78222E3
	3300	76 x 105	13.4	2.55	42	29	18332E3	58332E3	38332E3	78332E3
	4700	76 x 105	15.0	3.62	31	22	18472E3	58472E3	38472E3	78472E3
	4700	76 x 146	16.3	3.62	29	20	28472E3	68472E3	48472E3	88472E3
6800	76 x 146	18.3	5.24	22	16	18682E3	58682E3	38682E3	78682E3	
400	220	35 x 60	2.1	0.18	557	363	16221E3	56221E3	-	-
	330	35 x 60	2.5	0.26	383	254	16331E3	56331E3	-	-
	330	35 x 80	2.7	0.26	374	245	26331E3	66331E3	-	-
	470	35 x 80	3.1	0.38	271	180	16471E3	56471E3	-	-
	470	35 x 105	3.3	0.38	265	175	26471E3	66471E3	-	-
	680	35 x 105	3.9	0.55	191	128	16681E3	56681E3	-	-
	680	50 x 80	4.5	0.54	199	136	26681E3	66681E3	-	-
	1000	50 x 80	5.7	0.80	128	86	16102E3	56102E3	-	-
	1000	50 x 105	6.0	0.80	125	83	26102E3	66102E3	-	-
	1500	50 x 105	7.1	1.20	88	59	26152E3	66152E3	-	-
	2200	65 x 105	10.0	1.76	60	40	26222E3	66222E3	46222E3	86222E3
	3300	65 x 105	12.1	2.64	40	27	16332E3	56332E3	36332E3	76332E3
	3300	76 x 105	13.4	2.64	40	27	26332E3	66332E3	46332E3	86332E3
	4700	76 x 105	15.0	3.76	31	21	16472E3	56472E3	36472E3	76472E3
	4700	76 x 146	16.4	3.76	28	19	26472E3	66472E3	46472E3	86472E3
6800	76 x 146	18.3	5.44	22	15	26682E3	66682E3	46682E3	86682E3	
10000	76 x 220	22.1	8.0	14	11	16103E3	56103E3	36103E3	76103E3	
450	220	35 x 60	2.1	0.20	503	313	17221E3	57221E3	-	-
	330	35 x 80	2.7	0.30	339	212	27331E3	67331E3	-	-
	470	35 x 105	3.4	0.42	241	151	27471E3	67471E3	-	-
	680	50 x 80	4.9	0.61	159	98	27681E3	67681E3	-	-
	1000	50 x 80	5.7	0.90	118	75	17102E3	57102E3	-	-
	1000	50 x 105	6.1	0.90	114	72	27102E3	67102E3	-	-
	1500	50 x 105	7.1	1.35	81	52	17152E3	57152E3	-	-
	1500	65 x 105	8.3	1.35	81	52	27152E3	67152E3	47152E3	87152E3
	2200	65 x 105	10.1	1.98	55	35	17222E3	57222E3	37222E3	77222E3
	2200	76 x 105	11.2	1.98	55	35	27222E3	67222E3	47222E3	87222E3
	3300	76 x 105	13.5	2.97	37	24	17332E3	57332E3	37332E3	77332E3
	3300	76 x 146	13.9	2.97	37	24	27332E3	67332E3	47332E3	87332E3
	4700	76 x 146	16.4	4.23	26	17	17472E3	57472E3	37472E3	77472E3
	5600	76 x 146	17.3	5.04	23	15	17562E3	57562E3	37562E3	77562E3
	6800	76 x 220	19.8	6.1	25	20	17682E3	57682E3	37682E3	77682E3
6800	90 x 146	21.3	6.1	24	19	-	-	47682E3	87682E3	
10 000	90 x 220	26.5	9.0	17	14	-	-	47103E3	87103E3	



ADDITIONAL ELECTRICAL DATA		
PARAMETER	CONDITIONS	VALUE
Voltage		
Surge voltage	≤ 250 V versions	$U_s = 1.15 \times U_R$
	≥ 350 V versions	$U_s = 1.1 \times U_R$
Reverse voltage		$U_{rev} \leq 1 \text{ V}$
Current		
Leakage current in μA	After 1 minute at U_R	$I_{L1} \leq 0.006 C_R \times U_R$
	After 5 minutes at U_R	$I_{L5} \leq 0.002 C_R \times U_R$
Inductance		
Equivalent series inductance (ESL)	Case $\varnothing D = 35 \text{ mm}$	Typ. 13 nH
	Case $\varnothing D = 50 \text{ mm}$	Typ. 16 nH
	Case $\varnothing D = 65 \text{ mm}$	Typ. 19 nH ⁽¹⁾
	Case $\varnothing D = 76 \text{ mm}$	Typ. 20 nH ⁽¹⁾
	Case $\varnothing D = 90 \text{ mm}$	Typ. 21 nH ⁽¹⁾

Note

⁽¹⁾ Low ESL designs available on request

RIPPLE CURRENT AND USEFUL LIFE

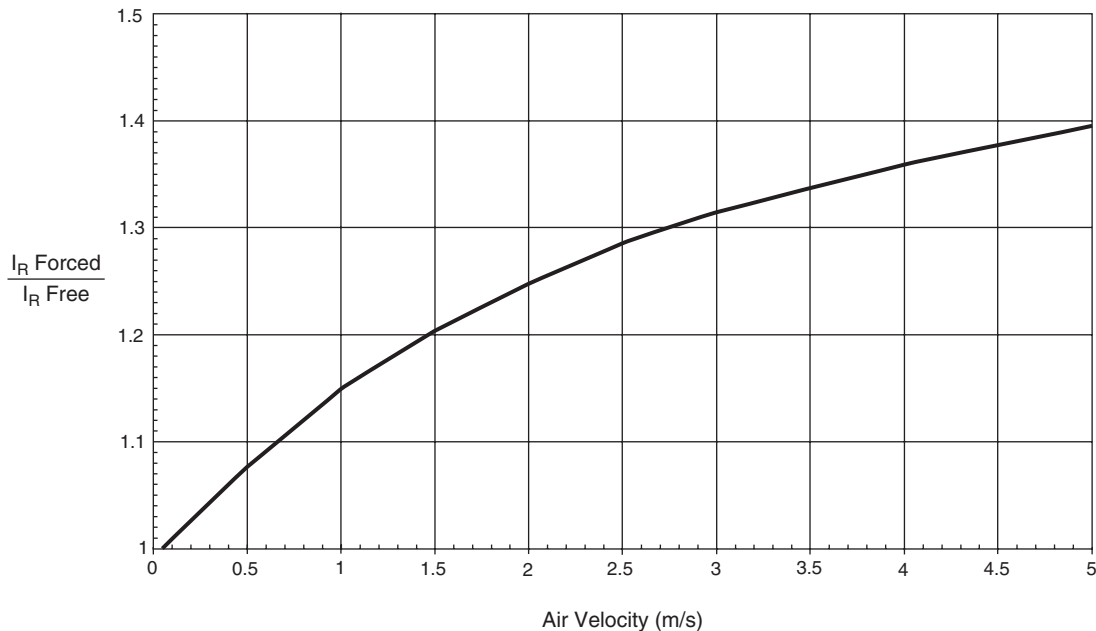
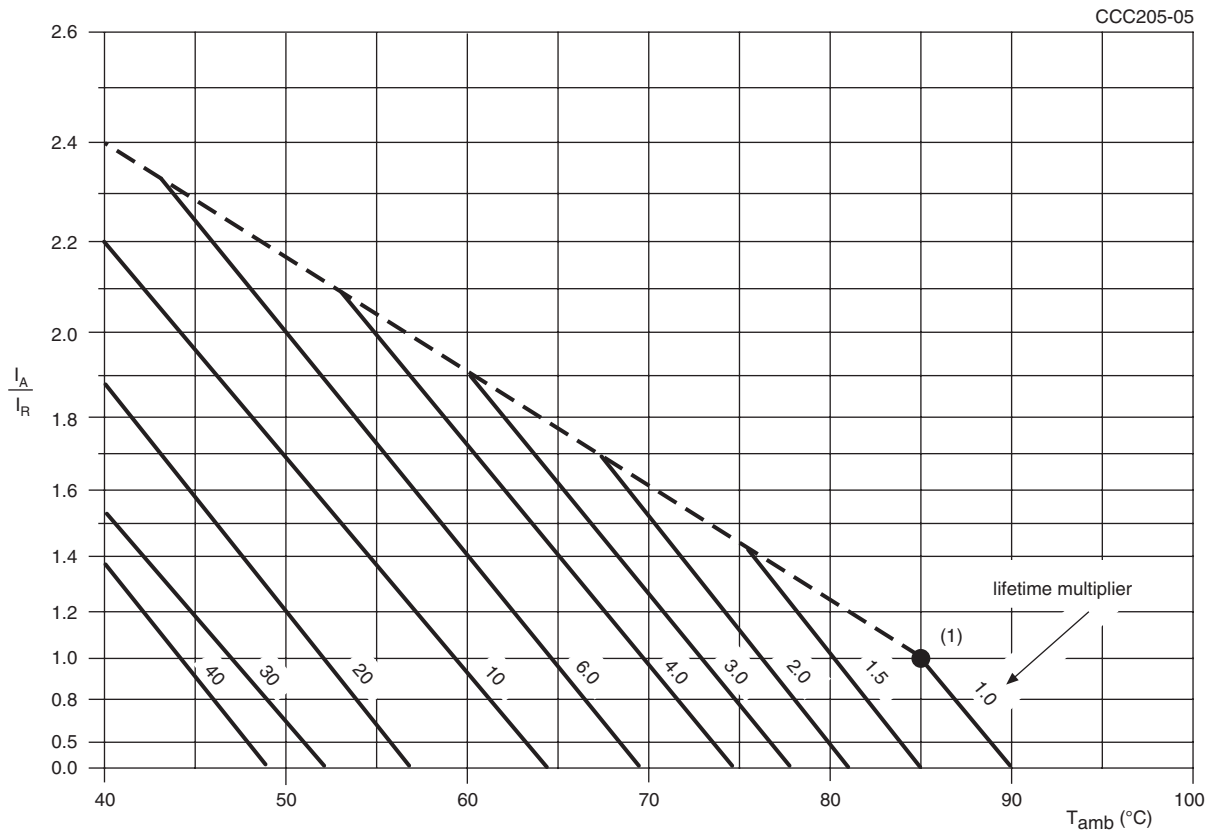


Fig.3 Multiplier of ripple current (I_R) as a function of air flow

MAXIMUM RIPPLE CURRENT			
PARAMETER	CONDITION	MAXIMUM RIPPLE CURRENT MULTIPLIER	VALUE
Ambient temperature (T_{amb})	70 °C	From nomogram; see fig. 4	1.6
Operating frequency (f)	400 Hz	From frequency; table 4	1.3
Air flow	2 m/s	From air-flow; see fig. 3	1.25

Note

• Calculation example for 102 series. Maximum ripple current multiplier = 1.6 x 1.3 x 1.25 = 2.6



I_A = actual ripple current at 100 Hz
 I_R = rated ripple current at 100 Hz and 85 °C

- (1) Useful life at 85 °C and I_R applied:
 101 series: case $\varnothing D \leq 50$: 10 000 h
 case $\varnothing D \geq 65$: 15 000 h
 102 series: 10 000 h

Fig.4 Multiplier of useful life as a function of ambient temperature and ripple current load

Table 4

MULTIPLIER OF RIPPLE CURRENT (I_R) AS A FUNCTION OF FREQUENCY		
FREQUENCY (Hz)	I_R MULTIPLIER	
	101	102
50	0.85	0.90
100	1.00	1.00
200	1.10	1.20
400	1.15	1.30
1000	1.20	1.40
10 000	1.30	1.50



Aluminum Capacitors
Power High Ripple Current Screw Terminals

Table 5

TEST PROCEDURES AND REQUIREMENTS			
TEST		PROCEDURE (quick reference)	REQUIREMENTS
NAME OF TEST	REFERENCE		
Endurance	IEC 60384-4/ EN130300 subclause 4.13	$T_{amb} = 85\text{ °C}$; U_R applied; 2000 hours	$U_R \leq 100\text{ V}$; $\Delta C/C$: $\pm 15\%$ $U_R > 100\text{ V}$; $\Delta C/C$: $\pm 10\%$ $\tan \delta \leq 1.3 \times \text{spec. limit}$ $Z \leq 2 \times \text{spec. limit}$ $I_{L5} \leq \text{spec. limit}$
Useful life	CECC 30301 subclause 1.8.1	$T_{amb} = 85\text{ °C}$; U_R and I_R applied; 101 series: Case $\varnothing D \leq 50$: 10 000 hours Case $\varnothing D \geq 65$: 15 000 hours 102 series: 10 000 hours	$U_R \leq 100\text{ V}$; $\Delta C/C$: $\pm 45\%$ $U_R > 100\text{ V}$; $\Delta C/C$: $\pm 30\%$ $\tan \delta \leq 3 \times \text{spec. limit}$ $Z \leq 3 \times \text{spec. limit}$ $I_{L5} \leq \text{spec. limit}$ No short or open circuit, No visible damage Total failure percentage: $U_R \leq 100\text{ V}$: $\leq 1\%$; $U_R > 100\text{ V}$: $\leq 3\%$
Shelf life (storage at high temperature)	IEC 60384-4/ EN130300 subclause 4.17	$T_{amb} = 85\text{ °C}$; no voltage applied; 500 hours After test: U_R to be applied for 30 minutes, 24 hours to 48 hours before measurement	$\Delta C/C$: $\pm 10\%$ $\tan \delta \leq 1.2 \times \text{spec. limit}$ $I_{L5} \leq 2 \times \text{spec. limit}$

Aluminum Capacitors Power Eurodin Screw Terminals

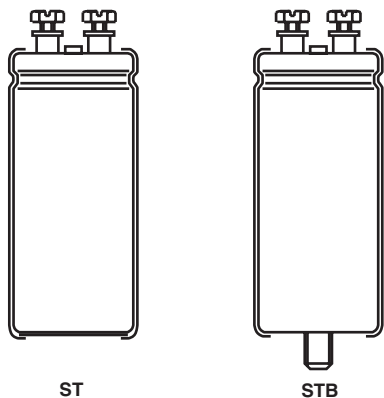


Fig.1 Component outlines

FEATURES

- Polarized aluminum electrolytic capacitors, non-solid electrolyte
- Large types, cylindrical aluminum case, insulated with a blue sleeve
- Also available in bolt version (106 PED-STB)
- Pressure relief in the sealing
- Charge and discharge proof
- Extremely low ESR and ESL allowing very high ripple current load
- Very long useful life: 20 000 hours at 85 °C
- High resistance to shock and vibration



RoHS
COMPLIANT

APPLICATIONS

- Computer, telecommunications and industrial systems
- Smoothing and filtering
- Standard and switched mode power supplies
- Energy storage in pulse systems

MARKING

The capacitors are marked with the following information:

- Rated capacitance (in μF)
- Tolerance on rated capacitance, code letter in accordance with IEC 60062 (Q for - 10 %/+ 30 %)
- Rated voltage (in V)
- Date code (YYMM)
- Name of manufacturer
- Code for factory of origin
- '-' sign to identify the negative terminal, visible from the top and side of the capacitor
- Code number
- Climatic category in accordance with IEC 60068
- "LL" for long life grade

QUICK REFERENCE DATA

DESCRIPTION	VALUE
Nominal case size (\varnothing D x L in mm)	35 x 60 to 90 x 220
Rated capacitance range (E6 series), C_R	1000 μF to 330 000 μF
Tolerance on C_R	- 10 % to + 30 %
Rated voltage range, U_R	25 V to 100 V
Category temperature range	- 40 °C to + 85 °C
Endurance test at 85 °C	8000 hours
Useful life at 85 °C	20 000 hours
Shelf life at 0 V, 85 °C	500 hours
Based on sectional specification	IEC 60384-4/EN130300
Climatic category IEC 60068	40/085/56

SELECTION CHART FOR C_R , U_R AND RELEVANT NOMINAL CASE SIZES (\varnothing D x L in mm)

C_R (μF)	U_R (V)			
	25	40	63	100
1000	-	-	-	35 x 60
1500	-	-	-	35 x 60
2200	-	-	35 x 60	35 x 80
3300	-	35 x 60	35 x 60	35 x 105
4700	35 x 60	35 x 60	35 x 80	50 x 80
6800	35 x 60	35 x 80	35 x 105	50 x 105
10 000	35 x 80	35 x 105	50 x 80	65 x 105
15 000	35 x 105	50 x 80	50 x 105	65 x 105
22 000	50 x 80	50 x 105	65 x 105	76 x 105
33 000	50 x 105	65 x 105	65 x 105	76 x 146

SELECTION CHART FOR C_R, U_R AND RELEVANT NOMINAL CASE SIZES ($\varnothing D \times L$ in mm)				
C_R (μF)	U_R (V)			
	25	40	63	100
47 000	65 x 105	65 x 105	76 x 105	76 x 220
68 000	65 x 105	76 x 105	76 x 146	90 x 220
100 000	76 x 105	76 x 146	76 x 220	-
150 000	76 x 146	76 x 220	-	-
	-	90 x 146	90 x 220	-
220 000	76 x 220	-	-	-
	90 x 146	90 x 220	-	-
330 000	90 x 220	-	-	-

DIMENSIONS in millimeters **AND AVAILABLE FORMS**

Fig. 2A: Standard M5 disc: screw terminal (ST) and screw terminal bolt nut (STB)

Fig. 2B: High current M6 disc: screw terminal (ST) and screw terminal bolt nut (STB)

Maximum permissible torque which may be applied to the termination screws: 2 Nm for M5; 2.5 Nm for M6
 For accessories refer to datasheet "Mounting Accessories".
 The capacitors are delivered with screws and washers.

Table 1

DIMENSIONS in millimeters, MASS AND PACKAGING QUANTITIES															
DESIGN	DRAWING	$L \pm 1$	$L_t \pm 1$	$D \pm 1$	$P \pm 0.3$	$T \pm 0.2$	$H \pm 0.3$	$B \pm 0.3$	$d_1 \pm 0.1$	M	S - 0	M_b	$l_b \pm 0.1$	MASS (g)	PACKAGING QUANTITIES
35 x 60	2A	63.3	68.7	35.3	12.8	7.0	4.6	11.0	7.9	M5	9.5	M8	12.0	75	50
35 x 80	2A	81.3	86.7	35.3	12.8	7.0	4.6	11.0	7.9	M5	9.5	M8	12.0	95	50
35 x 105	2A	103.3	108.7	35.3	12.8	7.0	4.6	11.0	7.9	M5	9.5	M8	12.0	130	50
50 x 80	2A	82.8	88.8	51.0	22.2	7.1	4.8	11.0	7.9	M5	9.5	M12	16.0	200	25
50 x 105	2A	104.8	110.8	51.0	22.2	7.1	4.8	11.0	7.9	M5	9.5	M12	16.0	300	25
65 x 105	2A	104.8	110.7	65.0	28.5	7.0	4.6	11.9	7.9	M5	9.5	M12	16.0	480	16
65 x 105 HC	2B	104.8	109.2	65.0	28.5	5.5	3.5	18.0	13.0	M6	8.5	M12	16.0	480	16
76 x 105	2A	105.8	111.7	76.4	31.8	7.0	4.6	11.7	7.9	M5	9.5	M12	16.0	700	12



DIMENSIONS in millimeters, MASS AND PACKAGING QUANTITIES															
DESIGN	DRAWING	L ± 1	L _t ± 1	D ± 1	P ± 0.3	T ± 0.2	H ± 0.3	B ± 0.3	d ₁ ± 0.1	M	S - 0	Mb	l _b ± 0.1	MASS (g)	PACKAGING QUANTITIES
76 x 105 HC	2B	105.8	110.2	76.4	31.8	5.5	3.5	18.3	13.0	M6	8.5	M12	16.0	700	12
76 x 114	2A	115.8	121.7	76.4	31.8	7.0	4.6	11.7	7.9	M5	9.5	M12	16.0	800	12
76 x 114 HC	2B	115.8	120.2	76.4	31.8	5.5	3.5	18.3	13.0	M6	8.5	M12	16.0	800	12
76 x 146	2A	145.8	151.7	76.4	31.8	7.0	4.6	11.7	7.9	M5	9.5	M12	16.0	1000	12
76 x 146 HC	2B	145.8	150.2	76.4	31.8	5.5	3.5	18.3	13.0	M6	8.5	M12	16.0	1000	12
76 x 220	2A	219.8	225.7	76.4	31.8	7.0	4.6	11.7	7.9	M5	9.5	M12	16.0	1500	10
76 x 220 HC	2B	219.8	224.2	76.4	31.8	5.5	3.5	18.3	13.0	M6	8.5	M12	16.0	1500	10
90 x 146 HC	2B	150.1	155.4	89.4	31.8	7.9	0.0	13.0	13.0	M6	10.0	M12	16.0	1300	10
90 x 220 HC	2B	218.1	223.4	89.4	31.8	7.9	0.0	13.0	13.0	M6	10.0	M12	16.0	2000	10

Note

- For bolt version holds:
 1. L = L standard - 0.5 mm
 2. L_t = L_t standard - 0.5 mm

ELECTRICAL DATA	
SYMBOL	DESCRIPTION
C _R	rated capacitance at 100 Hz, tolerance - 10 % to + 30 %
I _R	rated RMS ripple current at 100 Hz, 85 °C
I _{L5}	max. leakage current after 5 minutes at U _R
ESR	max. equivalent series resistance at 100 Hz
Z	impedance at 20 kHz

ORDERING EXAMPLE

Electrolytic capacitor 106 PED-ST series
 10 000 µF/25 V; - 10 %/+ 30 %
 Nominal case size: Ø 35 x 80 mm; ST version
 Ordering code: MAL2 106 16103 E3
 Former 12NC: 2222 106 16103

Note

- Unless otherwise specified, all electrical values in tables 2 and 3 apply at T_{amb} = 20 °C, P = 86 kPa to 106 kPa, RH = 45 % to 75 %

Table 2

ELECTRICAL DATA AND ORDERING INFORMATION										
U _R (V)	C _R 100 Hz (µF)	NOMINAL CASE SIZE Ø D x L (mm)	I _R 100Hz 85 °C (A)	I _{L5} 5 min (mA)	ESR max. 100 Hz (mΩ)	Z max. 20 kHz (mΩ)	STANDARD HIGH POST M5 DISC		HIGH CURRENT M6 DISC	
							ST ORDERING CODE MAL2106.....	ST BOLT NUT ORDERING CODE MAL2106.....	ST ORDERING CODE MAL2106.....	ST BOLT NUT ORDERING CODE MAL2106.....
25	4700	35 x 60	6.0	0.24	53	32	16472E3	56472E3	-	-
	6800	35 x 60	6.5	0.34	43	29	16682E3	56682E3	-	-
	10 000	35 x 80	7.9	0.50	32	22	16103E3	56103E3	-	-
	15 000	35 x 105	9.3	0.75	25	18	16153E3	56153E3	-	-
	22 000	50 x 80	14.0	1.10	15	11	16223E3	56223E3	-	-
	33 000	50 x 105	16.4	1.65	12	9	16333E3	56333E3	-	-
	47 000	65 x 105	23.2	3.35	8	6	16473E3	56473E3	36473E3	76473E3
	68 000	65 x 105	23.5	3.40	8	6	16683E3	56683E3	36683E3	76683E3
	100 000	76 x 105	30.1	5.00	6	5	16104E3	56104E3	36104E3	76104E3
	150 000	76 x 146	34.5	7.5	5	5	16154E3	56154E3	36154E3	76154E3
	220 000	76 x 220	40.8	11.0	5	5	16224E3	56224E3	36224E3	76224E3
	220 000	90 x 146	50	11.0	5	5	-	-	46224E3	86224E3
330 000	90 x 220	50	16.5	5	5	-	-	46334E3	86334E3	
40	3300	35 x 60	5.7	0.27	56	32	17332E3	57332E3	-	-
	4700	35 x 60	6.0	0.38	48	31	17472E3	57472E3	-	-
	6800	35 x 80	7.3	0.55	36	24	17682E3	57682E3	-	-
	10 000	35 x 105	10.9	0.80	19	11	17103E3	57103E3	-	-
	15 000	50 x 80	13.0	1.20	17	12	17153E3	57153E3	-	-
	22 000	50 x 105	15.2	1.76	13	10	17223E3	57223E3	-	-



ELECTRICAL DATA AND ORDERING INFORMATION										
U _R (V)	C _R 100 Hz (μF)	NOMINAL CASE SIZE Ø D x L (mm)	I _R 100Hz 85 °C (A)	I _{L5} 5 min (mA)	ESR max. 100 Hz (mΩ)	Z max. 20 kHz (mΩ)	STANDARD HIGH POST M5 DISC		HIGH CURRENT M6 DISC	
							ST ORDERING CODE MAL2106.....	ST BOLT NUT ORDERING CODE MAL2106.....	ST ORDERING CODE MAL2106.....	ST BOLT NUT ORDERING CODE MAL2106.....
40	33 000	65 x 105	21.6	2.64	9	7	17333E3	57333E3	37333E3	77333E3
	47 000	65 x 105	25.1	3.76	7	5	17473E3	57473E3	37473E3	77473E3
	100 000	76 x 146	31.8	8.0	5	5	17104E3	57104E3	37104E3	77104E3
	150 000	76 x 220	38.2	12.0	5	5	17154E3	57154E3	37154E3	77154E3
	150 000	90 x 146	50.0	12.0	5	5	-	-	47154E3	87154E3
	220 000	90 x 220	50.0	17.6	5	5	-	-	47224E3	87224E3
63	2200	35 x 60	5.6	0.28	56	32	18222E3	58222E3	-	-
	3300	35 x 60	7.4	0.42	32	17	18332E3	58332E3	-	-
	4700	35 x 80	9.0	0.60	24	13	18472E3	58472E3	-	-
	6800	35 x 105	10.8	0.86	18	10	18682E3	58682E3	-	-
	15 000	50 x 105	17.5	1.89	10	7	18153E3	58153E3	-	-
	10 000	50 x 80	14.8	1.26	13	8	18103E3	58103E3	-	-
	22 000	65 x 105	23.9	2.78	7	5	18223E3	58223E3	38223E3	78223E3
	33 000	65 x 105	23.9	4.16	7	5	18333E3	58333E3	38333E3	78333E3
	47 000	76 x 105	25.4	5.93	8	5	18473E3	58473E3	38473E3	78473E3
	68 000	76 x 146	29.8	8.6	6	5	18683E3	58683E3	38683E3	78683E3
	100 000	76 x 220	36.6	12.6	5	5	18104E3	58104E3	38104E3	78104E3
150 000	90 x 220	50.0	18.9	5	5	-	-	48154E3	88154E3	
100	1000	35 x 60	3.7	0.20	96	48	19102E3	59102E3	-	-
	1500	35 x 60	4.8	0.30	59	27	19152E3	59152E3	-	-
	2200	35 x 80	5.9	0.44	42	20	19222E3	59222E3	-	-
	3300	35 x 105	7.3	0.66	29	15	19332E3	59332E3	-	-
	4700	50 x 80	10.1	0.94	22	12	19472E3	59472E3	-	-
	6800	50 x 105	12.1	1.36	16	9	19682E3	59682E3	-	-
	10 000	65 x 105	16.7	2.00	11	7	19103E3	59103E3	39103E3	79103E3
	15 000	65 x 105	17.6	3.00	10	6	19153E3	59153E3	39153E3	79153E3
	22 000	76 x 105	19.5	4.40	9	6	19223E3	59223E3	39223E3	79223E3
	33 000	76 x 146	23.0	6.6	8	6	19333E3	59333E3	39333E3	79333E3
	47 000	76 x 220	28.6	9.4	5	5	19473E3	59473E3	39473E3	79473E3
	68 000	90 x 220	50.0	13.6	5	5	-	-	49683E3	89683E3

ADDITIONAL ELECTRICAL DATA		
PARAMETER	CONDITIONS	VALUE
Voltage		
Surge voltage		U _s = 1.15 x U _R
Reverse voltage		U _{rev} ≤ 1 V
Current		
Leakage current	After 1 minute at U _R	I _{L1} ≤ 0.006 C _R x U _R + 4 μF
	After 5 minutes at U _R	I _{L5} ≤ 0.002 C _R x U _R + 4 μF
Inductance		
Equivalent series inductance (ESL)	Case Ø D = 35 mm	typ. 13 nH
	Case Ø D = 50 mm	typ. 16 nH
	Case Ø D = 65 mm	typ. 19 nH ⁽¹⁾
	Case Ø D = 76 mm	typ. 20 nH ⁽¹⁾
	Case Ø D = 90 mm	typ. 21 nH ⁽¹⁾

Note

⁽¹⁾ Low ESL designs available on request

RIPPLE CURRENT AND USEFUL LIFE

CCC205-05

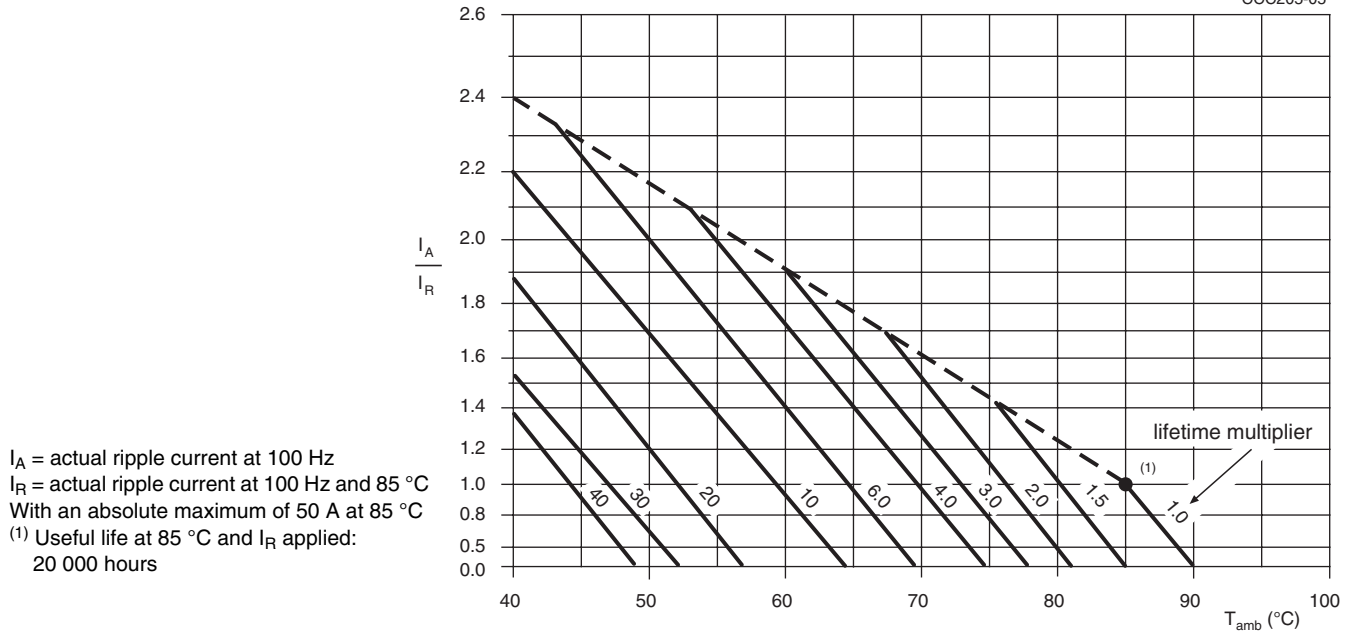


Fig.3 Multiplier of useful life as a function of ambient temperature and ripple current load

Table 3

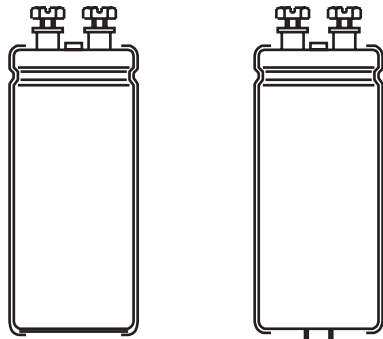
MULTIPLIER OF RIPPLE CURRENT (I_R) AS A FUNCTION OF FREQUENCY	
FREQUENCY (Hz)	I_R MULTIPLIER
50	0.83
100	1.00
200	1.10
400	1.15
1000	1.19
≥ 2000	1.20

Table 4

TEST PROCEDURES AND REQUIREMENTS			
TEST		PROCEDURE (quick reference)	REQUIREMENTS
NAME OF TEST	REFERENCE		
Endurance	IEC 60384-4/ EN130300 subclause 4.13	$T_{amb} = 85\text{ °C}$; U_R applied; 8000 hours	$\Delta C/C: \pm 15\%$ $\tan \delta \leq 1.3 \times \text{spec. limit}$ $Z \leq 2 \times \text{spec. limit}$ $I_{L5} \leq \text{spec. limit}$
Useful life	CECC 30301 subclause 1.8.1	$T_{amb} = 85\text{ °C}$; U_R and I_R applied; 20 000 hours	$\Delta C/C: \pm 4.5\%$ $\tan \delta \leq 3 \times \text{spec. limit}$ $Z \leq 3 \times \text{spec. limit}$ $I_{L5} \leq \text{spec. limit}$ no short or open circuit, no visible damage total failure percentage $\leq 1\%$
Shelf life (storage at high temperature)	IEC 60384-4/ EN130300 subclause 4.17	$T_{amb} = 85\text{ °C}$; no voltage applied; 500 hours after test: U_R to be applied for 30 minutes, 24 hours to 48 hours before measurement	$\Delta C/C: \pm 10\%$ $\tan \delta \leq 1.2 \times \text{spec. limit}$ $I_{L5} \leq 2 \times \text{spec. limit}$

Aluminum Capacitors

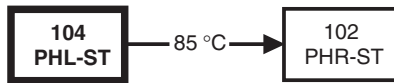
Power High Ripple Current Long Life Screw Terminals



ST

STB

Fig.1 Component outlines



FEATURES

- Polarized aluminum electrolytic capacitors, non-solid electrolyte
- Large types, cylindrical aluminum case, insulated with a blue sleeve
- Also available in bolt version (104 PHL-STB)
- Pressure relief in the sealing
- Long useful life


RoHS
COMPLIANT

APPLICATIONS

- Telecom and industrial, high temperature systems
- Smoothing and filtering
- Standard and switched mode power supplies
- Energy storage in pulse systems

MARKING

The capacitors are marked with the following information:

- Rated capacitance (in μF)
- Tolerance on rated capacitance, code letter in accordance with IEC 60062 ($\pm 20\%$)
- Rated voltage (in V)
- Date code (YYMM)
- Name of manufacturer
- Code for factory of origin
- '-' sign to identify the negative terminal, visible from the top and side of the capacitor
- Code number
- Climatic category in accordance with IEC 60068
- "LL" for long life grade

QUICK REFERENCE DATA

DESCRIPTION	VALUE
Nominal case size (\varnothing D x L in mm)	30 x 60 to 90 x 220
Rated capacitance range (E6 series), C_R	150 μF to 33 000 μF
Tolerance on C_R	$\pm 20\%$
Rated voltage range, U_R	200 V to 450 V
Category temperature range	- 40 °C to 105 °C
Endurance test at 105 °C	2000 hours
Useful life at 105 °C	5000 hours
Shelf life at 0 V, 105 °C	1000 hours
Based on sectional specification	IEC 60384-4/EN130300
Climatic category IEC 60068	40/105/56

SELECTION CHART FOR C_R , U_R AND RELEVANT NOMINAL CASE SIZES (\varnothing D x L in mm)

C_R (μF)	U_R (V)				
	200	250	350	400	450
150	-	-	-	-	35 x 60
220	-	-	-	35 x 60	35 x 80
330	-	-	35 x 60	35 x 80	35 x 105
470	-	-	35 x 80	35 x 80	50 x 80
680	35 x 60	35 x 60	35 x 105	50 x 80	50 x 105
	35 x 60	35 x 80	50 x 80	50 x 105	50 x 105
1000	35 x 80	35 x 105	-	-	65 x 105
	35 x 80	-	-	-	-
1500	35 x 80	35 x 105	50 x 105	50 x 105	65 x 105
	35 x 105	50 x 80	-	65 x 105	76 x 105
2200	35 x 105	50 x 80	65 x 105	65 x 105	76 x 105
	50 x 80	35 x 105	-	76 x 105	76 x 146

SELECTION CHART FOR C_R , U_R AND RELEVANT NOMINAL CASE SIZES ($\varnothing D \times L$ in mm)

C_R (μF)	U_R (V)				
	200	250	350	400	450
3300	50 x 80	50 x 105	-	76 x 105	76 x 146
3300	50 x 105	65 x 105	-	76 x 146	-
4700	50 x 105	65 x 105	-	76 x 146	76 x 220
	65 x 105	76 x 105	76 x 146	-	90 x 146
6800	65 x 105	76 x 105	76 x 146	76 x 220	90 x 220
	76 x 105	76 x 146	-	90 x 146	-
10 000	76 x 105	76 x 146	76 x 220	90 x 220	-
	76 x 146	-	90 x 146	-	-
15 000	76 x 146	76 x 220	90 x 220	-	-
	-	90 x 146	-	-	-
22 000	76 x 220	90 x 220	-	-	-
	90 x 146	-	-	-	-
33 000	90 x 220	-	-	-	-

DIMENSIONS in millimeters AND AVAILABLE FORMS

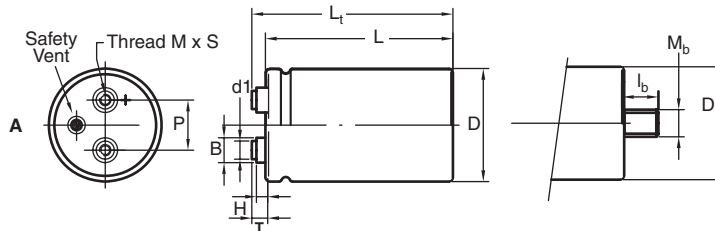


Fig. 2A: Standard M5 disc: screw terminal (ST) and screw terminal bolt nut (STB)

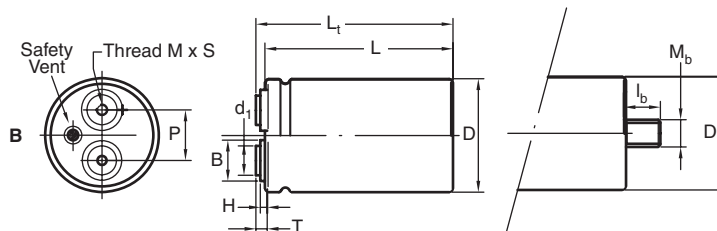


Fig. 2B: High current M6 disc: screw terminal (ST) and screw terminal bolt nut (STB)

Maximum permissible torque which may be applied to the termination screws: 2 Nm for M5; 2.5 Nm for M6
For accessories refer to datasheet "Mounting Accessories".
The capacitors are delivered with screws and washers.



Aluminum Capacitors
Power High Ripple Current
Long Life Screw Terminals

Vishay BCcomponents

Table 1

DIMENSIONS in millimeters, MASS AND PACKAGING QUANTITIES															
DESIGN	DRAWING	L ± 1	L _t ± 1	D ± 1	P ± 0.3	T ± 0.2	H ± 0.3	B ± 0.3	d ₁ ± 0.1	M	S - 0	Mb	l _b ± 0.1	MASS (g)	PACKAGING QUANTITIES
35 x 60	2A	63.3	68.7	35.3	12.8	7.0	4.6	11.0	7.9	M5	9.5	M8	12.0	75	50
35 x 80	2A	81.3	86.7	35.3	12.8	7.0	4.6	11.0	7.9	M5	9.5	M8	12.0	95	50
35 x 105	2A	103.3	108.7	35.3	12.8	7.0	4.6	11.0	7.9	M5	9.5	M8	12.0	130	50
50 x 80	2A	82.8	88.8	51.0	22.2	7.1	4.8	11.0	7.9	M5	9.5	M12	16.0	200	25
50 x 105	2A	104.8	110.8	51.0	22.2	7.1	4.8	11.0	7.9	M5	9.5	M12	16.0	300	25
65 x 105	2A	104.8	110.7	65.0	28.5	7.0	4.6	11.9	7.9	M5	9.5	M12	16.0	480	16
65 x 105 HC	2B	104.8	109.2	65.0	28.5	5.5	3.5	18.0	13.0	M6	8.5	M12	16.0	480	16
76 x 105	2A	105.8	111.7	76.4	31.8	7.0	4.6	11.7	7.9	M5	9.5	M12	16.0	700	12
76 x 105 HC	2B	105.8	110.2	76.4	31.8	5.5	3.5	18.3	13.0	M6	8.5	M12	16.0	700	12
76 x 114	2A	115.8	121.7	76.4	31.8	7.0	4.6	11.7	7.9	M5	9.5	M12	16.0	800	12
76 x 114 HC	2B	115.8	120.2	76.4	31.8	5.5	3.5	18.3	13.0	M6	8.5	M12	16.0	800	12
76 x 146	2A	145.8	151.7	76.4	31.8	7.0	4.6	11.7	7.9	M5	9.5	M12	16.0	1000	12
76 x 146 HC	2B	145.8	150.2	76.4	31.8	5.5	3.5	18.3	13.0	M6	8.5	M12	16.0	1000	12
76 x 220	2A	219.8	225.7	76.4	31.8	7.0	4.6	11.7	7.9	M5	9.5	M12	16.0	1500	10
76 x 220 HC	2B	219.8	224.2	76.4	31.8	5.5	3.5	18.3	13.0	M6	8.5	M12	16.0	1500	10
90 x 146 HC	2B	150.1	155.4	89.4	31.8	7.9	0.0	13.0	13.0	M6	10.0	M12	16.0	1300	10
90 x 220 HC	2B	218.1	223.4	89.4	31.8	7.9	0.0	13.0	13.0	M6	10.0	M12	16.0	2000	10

Note

- For bolt version holds:
1. L = L standard - 0.5 mm
2. L_t = L_t standard - 0.5 mm

ELECTRICAL DATA	
SYMBOL	DESCRIPTION
C _R	rated capacitance at 100 Hz, tolerance ± 20 %
I _R	rated RMS ripple current at 100 Hz, 105 °C
I _{L5}	max. leakage current after 5 minutes at U _R
ESR	max. equivalent series resistance at 100 Hz
Z	impedance at 20 kHz

Note

- Unless otherwise specified, all electrical values in table 2 apply at T_{amb} = 20 °C, P = 86 kPa to 106 kPa, RH = 45 % to 75 %.

ORDERING EXAMPLE

Electrolytic capacitor 104 PHL-ST series
4700 µF/250 V; ± 20 %
Nominal case size: Ø 65 x 105 mm; ST version
Ordering code: MAL210413472E3
Former 12NC: 2222 104 13472

Table 2

ELECTRICAL DATA AND ORDERING INFORMATION										
U _R (V)	C _R 100 Hz (μF)	NOMINAL CASE SIZE Ø D x L (mm)	I _R 100 Hz 105 °C (A)	I _{L5} 5 min (mA)	ESR max. 100 Hz (mΩ)	Z max. 20 kHz (mΩ)	STANDARD HIGH POST M5 DISC		HIGH CURRENT M6 DISC	
							ST ORDERING CODE MAL2104.....	ST BOLT NUT ORDERING CODE MAL2104.....	ST ORDERING CODE MAL2104.....	ST BOLT NUT ORDERING CODE MAL2104.....
200	680	35 x 60	2.9	0.28	197	117	12681E3	52681E3	-	-
	1000	35 x 60	3.3	0.40	148	94	12102E3	52102E3	-	-
	1000	35 x 80	3.7	0.40	137	83	22102E3	62102E3	-	-
	1500	35 x 80	4.1	0.60	102	66	12152E3	52152E3	-	-
	1500	35 x 105	4.6	0.60	95	59	22152E3	62152E3	-	-
	2200	35 x 105	5.0	0.88	74	49	12222E3	52222E3	-	-
	2200	50 x 80	6.7	0.88	63	39	22222E3	62222E3	-	-
	3300	50 x 80	8.2	1.32	42	26	12332E3	52332E3	-	-
	3300	50 x 105	8.2	1.32	44	28	22332E3	62332E3	-	-
	4700	50 x 105	9.9	1.88	31	19	12472E3	52472E3	-	-
	4700	65 x 105	11.6	1.88	31	19	22472E3	62472E3	42472E3	82472E3
	6800	65 x 105	13.7	2.72	22	14	12682E3	52682E3	32682E3	72682E3
	6800	76 x 105	15.2	2.72	22	14	22682E3	62682E3	42682E3	82682E3
	10 000	76 x 105	16.4	4.0	17	12	12103E3	52103E3	32103E3	72103E3
	10 000	76 x 146	16.9	4.0	17	12	22103E3	62103E3	42103E3	82103E3
	15 000	76 x 146	19.9	6.0	12	9	12153E3	52153E3	32153E3	72153E3
22 000	76 x 220	24.6	8.8	9	7	12223E3	52223E3	32223E3	72223E3	
22 000	90 x 146	28.5	8.8	8	6	-	-	42223E3	82223E3	
33 000	90 x 220	34.8	13.2	5	5	-	-	42332E3	82332E3	
250	680	35 x 60	2.9	0.34	176	99	13681E3	53681E3	-	-
	1000	35 x 80	3.7	0.50	123	70	13102E3	53102E3	-	-
	1000	35 x 105	4.0	0.50	116	63	23102E3	63102E3	-	-
	1500	35 x 105	4.5	0.75	86	51	13152E3	53152E3	-	-
	1500	50 x 80	5.9	0.75	76	41	23152E3	63152E3	-	-
	2200	50 x 80	6.6	1.10	58	34	13222E3	53222E3	-	-
	2200	50 x 105	7.3	1.10	54	30	23222E3	63222E3	-	-
	3300	50 x 105	8.9	1.65	36	20	13332E3	53332E3	-	-
	3300	65 x 105	10.4	1.65	36	20	23332E3	63332E3	43332E3	83332E3
	4700	65 x 105	11.4	2.35	28	17	13472E3	53472E3	33472E3	73472E3
	4700	76 x 105	12.7	2.35	28	17	23472E3	63472E3	43472E3	83472E3
	6800	76 x 105	15.0	3.40	20	12	13682E3	53682E3	33682E3	73682E3
	6800	76 x 146	15.4	3.40	20	12	23682E3	63682E3	43682E3	83682E3
	10 000	76 x 146	18.2	5.0	14	9	13103E3	53103E3	33103E3	73103E3
	15 000	76 x 220	22.7	7.5	10	7	13153E3	53153E3	33153E3	73153E3
	15 000	90 x 146	25.8	7.5	9	6	-	-	43153E3	83153E3
22 000	90 x 220	30.4	11.0	7	5	-	-	43223E3	83223E3	
350	330	35 x 60	2.1	0.26	396	243	15331E3	55331E3	-	-
	470	35 x 80	2.6	0.33	280	172	15471E3	55471E3	-	-
	680	35 x 105	3.2	0.48	197	122	15681E3	55681E3	-	-
	1000	50 x 80	4.7	0.70	132	82	15102E3	55102E3	-	-
	1500	50 x 105	5.9	1.05	90	57	15152E3	55152E3	-	-
	2200	65 x 105	8.4	1.54	61	38	15222E3	55222E3	35222E3	75222E3
	3300	65 x 105	10.1	2.31	42	26	15332E3	55332E3	35332E3	75332E3
	3300	76 x 105	11.2	2.31	42	26	25332E3	65332E3	45332E3	85332E3
	4700	76 x 105	12.6	3.29	32	21	15472E3	55472E3	35472E3	75472E3
	4700	76 x 146	13.7	3.29	30	19	25472E3	65472E3	45472E3	85472E3
	6800	76 x 146	15.4	4.76	22	15	15682E3	55682E3	35682E3	75682E3
	10 000	76 x 220	18.5	7.0	20	18	15103E3	55103E3	35103E3	75103E3
	10 000	90 x 146	20.5	7.0	19	17	-	-	45103E3	85103E3
	15 000	90 x 220	25.6	10.5	13	12	-	-	45153E3	85153E3



Aluminum Capacitors
Power High Ripple Current
Long Life Screw Terminals

Vishay BCcomponents

ELECTRICAL DATA AND ORDERING INFORMATION										
U _R (V)	C _R 100 Hz (µF)	NOMINAL CASE SIZE Ø D x L (mm)	I _R 100 Hz 105 °C (A)	I _{L5} 5 min (mA)	ESR max. 100 Hz (mΩ)	Z max. 20 kHz (mΩ)	STANDARD HIGH POST M5 DISC		HIGH CURRENT M6 DISC	
							ST ORDERING CODE	ST BOLT NUT ORDERING CODE	ST ORDERING CODE	ST BOLT NUT ORDERING CODE
							MAL2104.....	MAL2104.....	MAL2104.....	MAL2104.....
400	220	35 x 60	1.8	0.18	519	290	16221E3	56221E3	-	-
	330	35 x 80	2.3	0.27	349	196	16331E3	56331E3	-	-
	470	35 x 80	2.6	0.38	254	148	16471E3	56471E3	-	-
	680	50 x 80	4.1	0.55	170	96	26681E3	66681E3	-	-
	1000	50 x 105	5.1	0.80	117	67	16102E3	56102E3	-	-
	1500	50 x 105	6.0	1.20	83	49	16152E3	56152E3	-	-
	1500	65 x 105	6.9	1.20	83	49	26152E3	66152E3	46152E3	86152E3
	2200	65 x 105	8.4	1.76	56	33	16222E3	56222E3	36222E3	76222E3
	2200	76 x 105	9.4	1.76	56	33	26222E3	66222E3	46222E3	86222E3
	3300	76 x 105	11.3	2.64	38	23	16332E3	56332E3	36332E3	76332E3
	3300	76 x 146	11.6	2.64	38	23	26332E3	66332E3	46332E3	86332E3
	4700	76 x 146	13.8	3.76	27	17	16472E3	56472E3	36472E3	76472E3
	6800	76 x 220	16.5	5.4	25	20	16682E3	56682E3	36682E3	76682E3
6800	90 x 146	17.7	5.4	25	20	-	-	46682E3	86682E3	
	10 000	90 x 220	22.1	8.0	17	14	-	-	46103E3	86103E3
450	150	35 x 60	1.5	0.14	735	404	17151E3	57151E3	-	-
	220	35 x 80	1.9	0.20	503	278	17221E3	57221E3	-	-
	330	35 x 105	2.4	0.30	339	189	17331E3	57331E3	-	-
	470	50 x 80	3.3	0.43	253	148	17471E3	57471E3	-	-
	680	50 x 105	4.3	0.62	165	92	17681E3	57681E3	-	-
	1000	50 x 105	5.1	0.90	117	67	17102E3	57102E3	-	-
	1000	65 x 105	5.9	0.90	116	66	27102E3	67102E3	47102E3	87102E3
	1500	65 x 105	7.3	1.35	77	44	17152E3	57152E3	37152E3	77152E3
	1500	76 x 105	8.1	1.35	77	44	27152E3	67152E3	47152E3	87152E3
	2200	76 x 105	9.7	1.98	53	31	17222E3	57222E3	37222E3	77222E3
	2200	76 x 146	10.0	1.98	53	31	27222E3	67222E3	47222E3	87222E3
	3300	76 x 146	12.1	2.97	36	21	17332E3	57332E3	37332E3	77332E3
	4700	76 x 220	14.1	4.2	33	25	17472E3	57472E3	37472E3	77472E3
	4700	90 x 146	15.3	4.2	31	24	-	-	47472E3	87472E3
	6800	90 x 220	18.9	6.1	22	17	-	-	47682E3	87682E3

ADDITIONAL ELECTRICAL DATA		
PARAMETER	CONDITIONS	VALUE
Voltage		
Surge voltage	≤ 250 V versions	U _s = 1.15 x U _R
	≥ 350 V versions	U _s = 1.1 x U _R
Reverse voltage		U _{rev} ≤ 1 V
Current		
Leakage current	After 1 minute at U _R	I _{L1} ≤ 0.006 C _R x U _R + 4 µA
	After 5 minutes at U _R	I _{L5} ≤ 0.002 C _R x U _R + 4 µA
Inductance		
Equivalent series inductance (ESL)	Case Ø D = 35 mm	typ. 13 nH
	Case Ø D = 50 mm	typ. 16 nH
	Case Ø D = 65 mm	typ. 19 nH ⁽¹⁾
	Case Ø D = 76 mm	typ. 20 nH ⁽¹⁾
	Case Ø D = 90 mm	typ. 21 nH ⁽¹⁾

Note

⁽¹⁾ Low ESL designs available on request

RIPPLE CURRENT AND USEFUL LIFE

CCC206-5

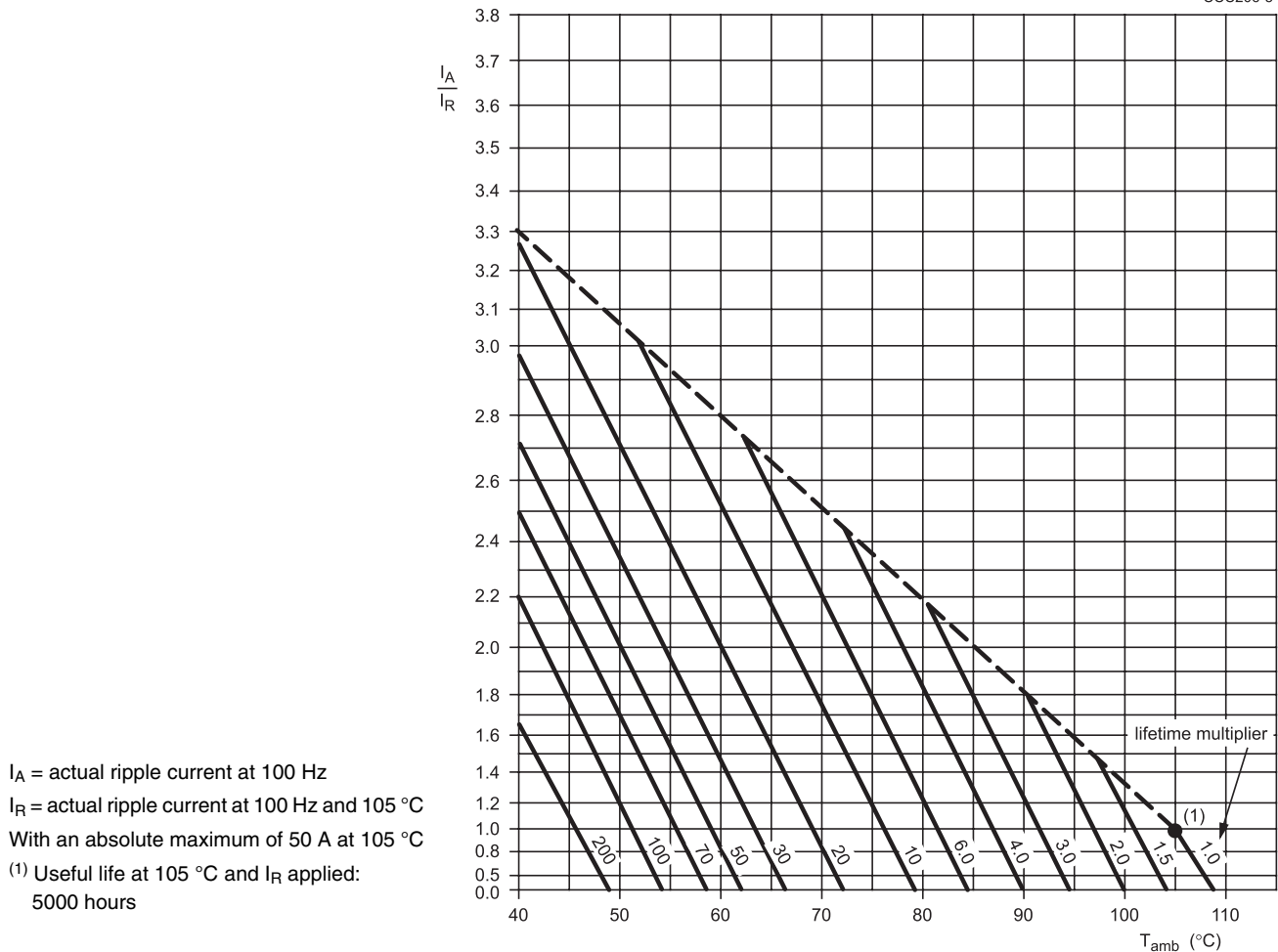


Fig. 3 Multiplier of useful life as a function of ambient temperature and ripple current load

Table 3

MULTIPLIER OF RIPPLE CURRENT (I_R) AS A FUNCTION OF FREQUENCY	
FREQUENCY (Hz)	I_R MULTIPLIER
50	0.90
100	1.00
200	1.20
400	1.30
1000	1.40
10 000	1.50



Aluminum Capacitors
Power High Ripple Current
Long Life Screw Terminals

Vishay BCcomponents

Table 4

TEST PROCEDURES AND REQUIREMENTS			
TEST		PROCEDURE (quick reference)	REQUIREMENTS
NAME OF TEST	REFERENCE		
Endurance	IEC 60384-4/ EN130300 subclause 4.13	$T_{amb} = 105\text{ }^{\circ}\text{C}$; U_R applied; 2000 hours	$\Delta C/C: \pm 10\%$ $ESR \leq 1.3 \times \text{spec. limit}$ $Z \leq 2 \times \text{spec. limit}$ $I_{L5} \leq \text{spec. limit}$
Useful life	CECC 30301 subclause 4.13	$T_{amb} = 105\text{ }^{\circ}\text{C}$; U_R and I_R applied; 5000 hours	$\Delta C/C: \pm 30\%$ $ESR \leq 3 \times \text{spec. limit}$ $Z \leq 3 \times \text{spec. limit}$ $I_{L5} \leq \text{spec. limit}$ no short or open circuit, no visible damage total failure percentage $\leq 3\%$
Shelf life (storage at high temperature)	IEC 60384-4/ EN130300 subclause 4.17	$T_{amb} = 105\text{ }^{\circ}\text{C}$; no voltage applied; 1000 hours after test: U_R to be applied for 30 minutes, 24 hours to 48 hours before measurement	$\Delta C/C: \pm 10\%$ $ESR \leq 1.2 \times \text{spec. limit}$ $I_{L5} \leq 2 \times \text{spec. limit}$





Vishay Roederstein

Contents

Introduction	192
EYN	206
EYH	214
EYC	222
EYD	230
EYK	236
EYV	240
EY	246
EYZ	250

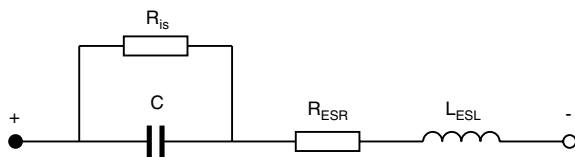
Aluminum Capacitors

SYMBOLS AND TECHNICAL TERMS	
SYMBOLS	DESCRIPTION
C	Capacitance
C_R	Rated capacitance
U	Voltage
U_R	Rated voltage
U_S	Surge voltage
U_B	Working voltage, operating voltage
U_{rev}	Reverse voltage
I, I~, I _{AC}	Alternating current
I_R	Rated alternating current, ripple current
I_L	Leakage current
I_{Lt}	Leakage current for acceptance test
I_{LB} , I _{OP}	Operational leakage current
R	Resistance
R_{ESR} ; ESR	Equivalent series resistance
R_{is}	Insulation resistance
L	Inductance
L_{ESL} , ESL	Equivalent series inductance
$\tan \delta$	Dissipation factor (tangent of loss angle)
Z	Impedance
X	Reactance
X_C , Z_C	Capacitive reactance
X_L , Z_L	Inductive reactance
T	Temperature
T_{amb}	Ambient temperature
T_s	Surface temperature
ΔT	Difference of temperature, temperature rise
T_{UC}	Upper category temperature
T_{LC}	Lower category temperature
f	Frequency
f_r	Resonance frequency
$\omega = 2 \pi f$	Angular frequency
F_s	Case surface area
λ	Failure rate
L	Lifetime multiplier

DESIGN AND POLARITY

The dielectric of an electrolytic capacitor with aluminum electrodes is made of aluminum oxide. One end of the dielectric sits firmly on an aluminum foil - the anode - while the other end sits on a liquid or solid electrolyte - the cathode. Power to the cathode is supplied via a second aluminum foil having a natural oxide layer as a dielectric with a blocking effect of just 1 to 2 V. (Many years of use have resulted in wrongly describing this power supply foil as 'cathode'). In its basic design the electrolytic capacitor is thus a direct current polarity-dependent capacitor (polarized style) with the positive pole being applied to the anode.

Apart from these so-called polarized electrolytic capacitors there are non-polarized capacitors available where the power supply foil is replaced by a second anode foil of the same type (non-polarized, bipolar style). This specific design allows operation with direct current of any polarity, as well as with pure alternating current.



C = capacitance of the oxide layer
 R_{is} = oxide layer insulation resistance
 R_{ESR} = equivalent series resistance
 L_{ESL} = equivalent series inductance

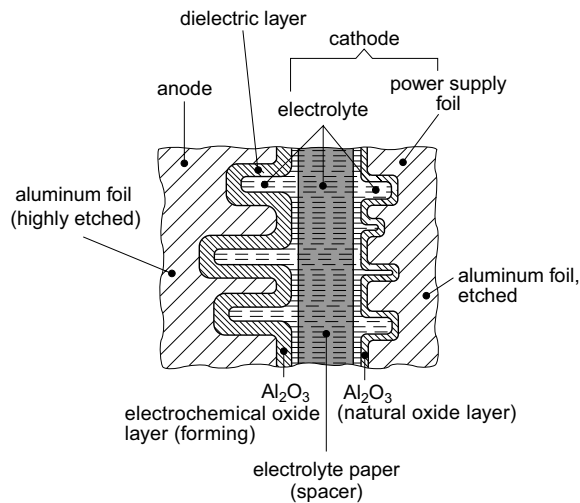


Fig.1 Basic design of an electrolytic capacitor and equivalent circuit diagram

CLASSIFICATION

Depending on applications and requirements, electrolytic capacitors are classified as:

- a) Long-life grade (LL)
Electrolytic capacitors designed for increased requirements.
- b) General-purpose grade (GP)
Electrolytic capacitors designed for general requirements.

Furthermore, all capacitor types have been subdivided by their application classes according to DIN 40040.

STORAGE LIFE

During transport or storage, the temperature of electrolytic capacitors is allowed to fall below their lower category temperature and reach a minimum of - 65 °C, while their upper category temperature may not be exceeded.

Depending on the design and the purity of the materials used, electrolytic capacitors offer very good storage properties. They can be stored in dry rooms at temperature ranging from - 40 °C to + 40 °C (preferably between 0 °C and + 25 °C) for up to three years without any restriction. Within that period it is possible to apply the fully-rated voltage to the capacitors without any further preparation. This procedure neither impairs the capacitor's operational reliability nor its life expectancy.

All electrolytic capacitors have a leakage current when a direct current is applied. This leakage current depends on time, voltage, and temperature. After long dead storage this leakage current will increase and, for a short time, can be 10 times greater at the time of reuse. The capacitor will not be damaged and its life expectancy will not be impaired if the rated voltage is applied directly after long storage. In general, the expected continuous operating leakage current will be re-attained or fall below its value after about 30 minutes. Any operation below the rated voltage will result in a significantly lower leakage current.

ELECTRICAL PARAMETERS

Rated Voltage U_R and Operating Voltage U_B

The rated voltage is defined as the voltage for which the capacitor has been designed and after which it is designated. The operating voltage may be smaller, but may never exceed the rated voltage value. A reduction in the operating voltage will not significantly increase the capacitor's lifetime. The capacitors may be charged with the specified rated direct voltage in the specified operating temperature range. In case of ripple alternating voltage, the peak voltage value must not exceed the rated value.

ELECTRICAL PARAMETERS (Continued)

Surge Voltage U_S

The surge voltage is defined as the maximum voltage which may be applied to the capacitor for a short time only (in one hour a maximum of five times with a duration of one minute each.) The surge voltage may not be used for periodic charge and discharge.

$$U_S = 1.15 \times U_R \text{ for } U_R \leq 250 \text{ V}$$

$$U_S = 1.10 \times U_R \text{ for } U_R > 250 \text{ V}$$

Ripple Alternating Voltage

The ripple voltage is defined as the effective value alternating voltage with which the capacitor may be charged in addition to direct voltage. The peak value of resulting ripple DC voltage must not exceed the rated voltage value. A reverse polarity voltage with a peak value of $> 1.5 \text{ V}$ must not occur.

Reverse Voltage U_{rev}

A reverse polarity of up to 1.5 V is permissible.

CAPACITANCE

Rated Capacitance C_R

The rated capacitance is defined as the capacitance value, after which the capacitor has been designated. The capacitance value may vary within the permissible tolerance limits.

Alternating Voltage Capacitance C_W

The AC capacitance normally corresponds to the rated capacitance value. It is determined by measuring the AC resistance at an AC voltage of $\leq 0.5 \text{ V}$. Since AC capacitance depends on frequency and temperature, a specific measuring frequency and temperature have to be agreed upon. IEC 60384-4 stipulates a frequency of 100 Hz and a temperature of $20 \text{ }^\circ\text{C}$.

Direct Voltage Capacitance C_{DC}

The DC capacitance is determined from the quantity of charge which is stored after a DC voltage charging of the capacitor. The measurement is effected during a single discharge under specified conditions. The measuring procedures are described in DIN 41 328. If both values, C and C_{DC} , are measured at an electrolytic capacitor, the result will always be: $C < C_{DC}$.

Depending on the design $C_{DC} \approx (1.05 \dots 1.30) \times C$.

Temperature Dependence of AC Capacitance

The measured AC capacitance decreases with falling temperatures. Falling temperatures result in an increased viscosity of electrolyte and thus in an increasing ohmic resistance. In fact, a model calculation shows that the total

capacitance of capacitive surface elements which are parallel connected via different series resistors R_1, R_2 , etc. will decrease, if the series resistors increase. Usually this behavior is described as follows: "High-resistive coupled surface elements have a lower capacitive effect."

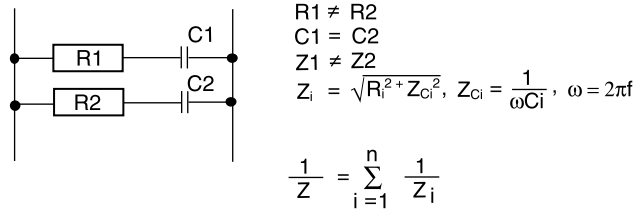


Fig.2 Detail from an equivalent circuit diagram for two surface elements

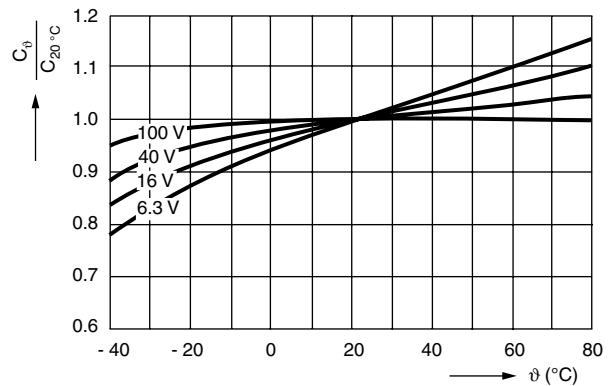


Fig.3: Typical temperature dependent behavior of AC capacitance

Frequency Dependence of AC Capacitance

The frequency dependence of AC capacitance is similar to its temperature dependence. The capacitive partial resistance Z_{Ci} decreases with increasing frequency f . At the same time the influence of the ohmic partial resistance R_i of the AC resistance Z_i is increasing. In this case, too, "high-resistive coupled surface elements have a lower capacitive effect".

EQUIVALENT SERIES RESISTANCE R_{ESR}

The equivalent series resistance is defined as the ohmic part of the AC resistance describing the losses occurring in an electrolytic capacitor. It consists of three partial resistance values: the lead and the foil resistance, the electrolyte paper resistance, and the oxide layer resistance. Just as any other ohmic resistance, R_{ESR} is temperature-dependent, too. Moreover, it contains a frequency-dependent part - the oxide layer resistance. R_{ESR} is usually calculated from the dissipation factor $\tan \delta$ as follows:

EQUIVALENT SERIES RESISTANCE R_{ESR}
(Continued)

$$R_{ESR} = \frac{\tan \delta}{\omega C} = \frac{\tan \delta}{2 \times \pi \times f \times C}$$

R_{ESR}	(Ω)
C	(F)
f	(Hz)

In practical operation the lower limit of the R_{ESR} is given by the ohmic part of the contact points and the foil resistance values. Thus it will not always be possible to achieve calculated values below 0.03 Ω .

The foil resistance and R_{ESR} can further be reduced by using the multiple tab technique. This technique consists of creating multiple contact points with the outer contact elements distributed uniformly across the anode and cathode foils. At the same time, the R_{ESR} -dependent capacitor values such as the dissipation factor, the impedance, and the maximum AC rating are clearly improved.

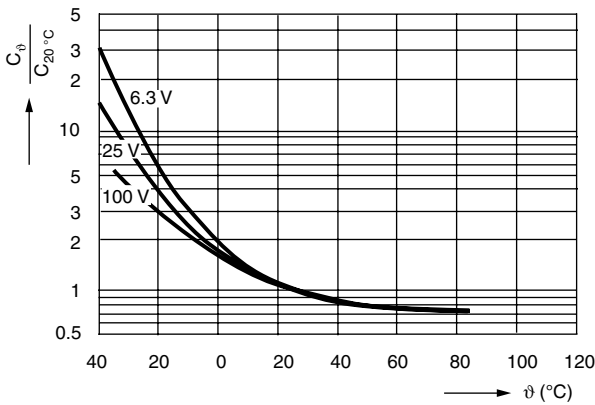


Fig.4 Temperature dependence of R_{ESR} (approx. values)

DISSIPATION FACTOR $\tan \delta$

The dissipation factor $\tan \delta$ is defined as the ratio between the equivalent series resistance R_{ESR} reactance $Z_{L,C} = \omega L - 1/\omega C$ (see Fig. 5). It is frequency-dependent via the reactance $Z_{L,C}$ and temperature dependent via the equivalent series resistance R_{ESR} .

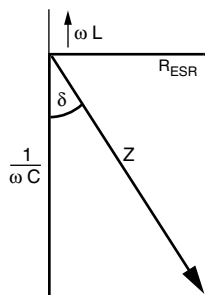


Fig.5 Vector diagram of the AC values of an electrolytic capacitor

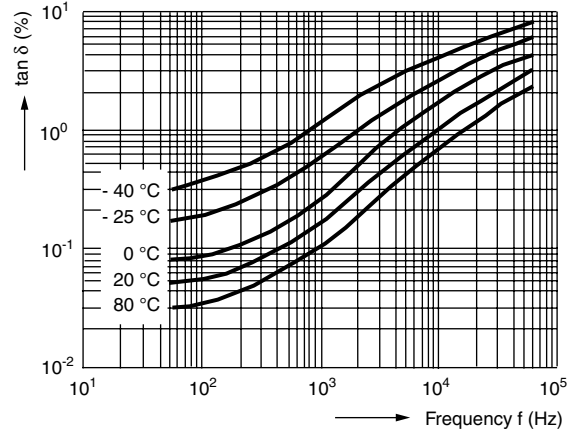


Fig.6 Typical frequency dependence of $\tan \delta$ at

IMPEDANCE Z

The amount of impedance Z of an electrolytic capacitor is calculated from the geometrical sum of the capacitive reactance $Z_C = 1/\omega C$ of the inductive reactance $Z_L = \omega L$ and of the equivalent series resistance R_{ESR} .

$$Z = \sqrt{R_{ESR}^2 + (\omega L - 1/\omega C)^2}$$

Figure 7 shows the ideal frequency curve of the impedance indicated on a double-logarithmic scale. The strong temperature dependence of the R_{ESR} value can also be seen.

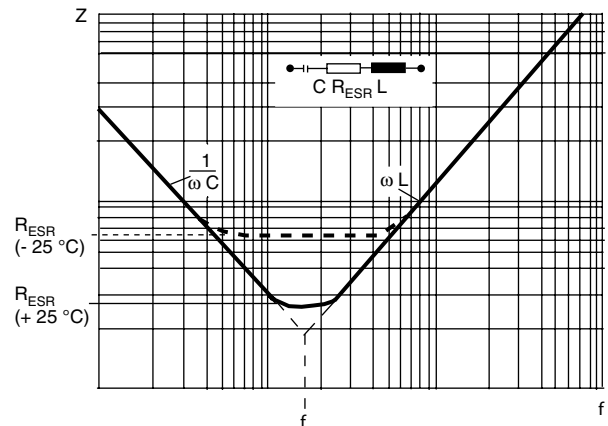


Fig.7 Idealized frequency dependent impedance curve at +25°C and -25°C

LEAKAGE CURRENT I_L

The leakage current is defined as the current flowing through the capacitor when a direct voltage is applied subsequent to the charging of the capacitor. Generally speaking, this leakage current is caused by 'defects' in the oxide dielectric. These defects range from crystal defects, stress, cracks, and installation-related damage, to a partial solution caused by the operating electrolyte. The leakage current is a measure of the 'forming state', i.e. of the regeneration to be effected on the oxide dielectric. This current depends on a multitude of factors, such as time, voltage, temperature, type of electrolyte, and 'history' of the capacitor.

Time Dependence of the Leakage Current

At the moment the measuring voltage is applied, a peak current occurs which depends on the capacitor's forming state as well as on the internal resistance of the voltage source. When the measuring voltage (charging of the capacitor) is reached, the current first drops with time until it takes on a small, nearly constant final value which ideally is only determined by the dynamic balance (temperature and voltage dependent) between the build-up and reduction of the oxide layer. This value is the operational leakage current I_{LB} . As can be expected, the operational leakage current level depends on the (measuring) voltage applied and on the temperature. Furthermore, the value of the operational leakage current is determined by the effective surface of the etched aluminum foil (capacitance of the capacitor), the type of electrolyte, and the level of the anode's (pre)forming voltage. Since the measurement of the operational leakage current, due to the long measurement period ($10 < t_M < 60$ min), will be feasible only in specific cases, shorter measurement periods of preferably one minute or five minutes have been accepted for general measurement regulations. The values measured in this way are described as leakage current for acceptance tests. In this case, the measuring voltage corresponds to the rated voltage of the capacitor.

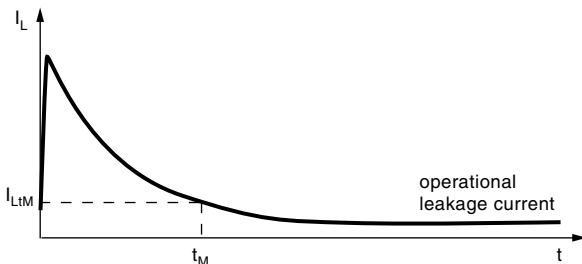


Fig.8: Typical variation with time of the leakage current

Voltage Dependence of the Leakage Current

Figure 9 shows the qualitative leakage current behavior. The leakage current I_L increases with the operating voltage U_B . The more the operating voltage approaches the (pre)forming voltage U_F of the anode, the steeper the slope (exponential

rise), especially after exceeding the rated voltage U_R . The leakage current, however, loses more and more of its original meaning. Specifically in the $U_S...U_F$ range the current can no longer be described as the measure of the regeneration work to be effected on the oxide layer. Above the surge voltage U_S there is an increasing tendency towards secondary reactions such as temperature rise, heavy formation of gas, electrolyte degradation, and inappropriate formation of oxide. For this reason any continuous operation above the rated voltage U_R is not tolerable. The conditions for exceeding the rated voltage on a short-time basis are stipulated under the heading 'surge voltage' (see surge voltage U_S).

The hatched area in Figure 9a illustrates an empirical evaluation of practical leakage current measurements. It shows the recommended approximate values for the relative leakage current dependence of U_B for $U_B \leq U_R$.

Curve A describes a small capacitor with a low rated voltage (e.g. 6 V) and a one minute leakage current value in the order of 1 μA . Curve B is typical of a middle sized high-voltage capacitor (e.g. $U_R = 350$ V) with a 1-minute leakage current value of approximately 100 μA (at room temperature).

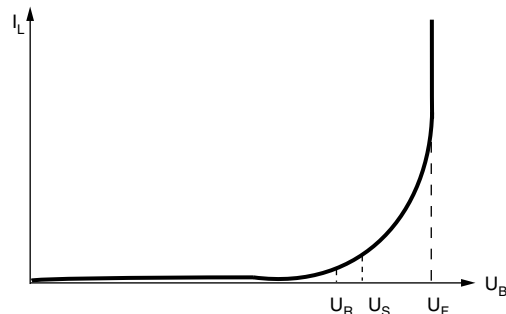


Fig.9 Typical variation of leakage current with applied voltage

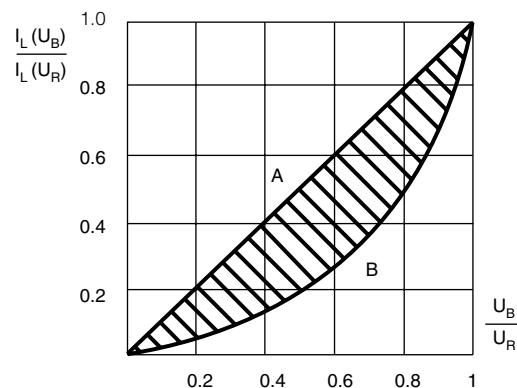


Fig.9a Typical size dependant relation (see text)

LEAKAGE CURRENT I_L (Continued)

Temperature Dependence of the Leakage Current

Although there are numerous causes for leakage current, only one can be described as having a more clearly defined temperature dependence - i.e. the dynamic balance between partial solution and build-up of the oxide layer. As a measure of this parameter the operating leakage current I_{LB} has been introduced under section 'Time dependence of the leakage current'. The model of the rate of (electro) chemical reactions increasing with temperature can be qualitatively applied here. Hence it follows that I_{LB} increases with temperature. Figure 10 shows some empirical values.

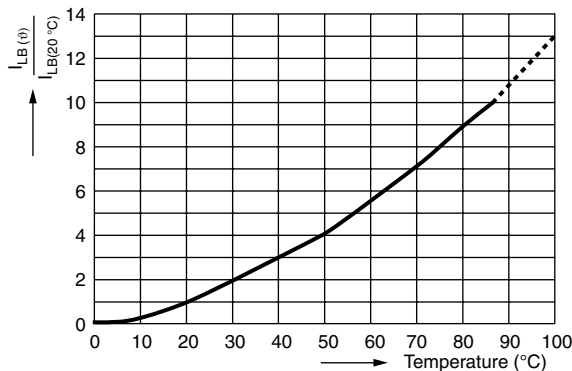


Fig.10 typical variation of leakage current with temperature

Leakage Current for Acceptance Test I_{Lt}

IEC 60384-4 and EN 130300 stipulate the measurement procedures for determining the leakage current for acceptance tests I_{Lt} . Based on these standards and due to different measuring periods (30 s, $I_{L0.5}$; 2 min, I_{L2} ; 5 min, I_{L5}) the threshold values for the Vishay Roederstein electrolytic capacitors are those that are calculated from the leakage current equations of the respective type specifications.

ALTERNATING CURRENT

The alternating current is defined as the effective value of the alternating current with which the capacitor is charged.

Rated Alternating Current I_R

The permissible rated alternating current is defined in such a way that at an upper category temperature T_{UC} and at a frequency of 100 Hz (measuring frequency of capacitance and dissipation factor), the temperature of the case surface area rises by 3 K. The resulting AC values I_R are indicated in the datasheets for each capacitor.

Maximum Permissible Alternating Current I, AC Rating

The maximum permissible alternating current rating depends on ambient temperature T_{amb} , case surface area F_s , equivalent series resistance R_{ESR} (or the dissipation factor $\tan \delta$), as well as on excess surface temperature ΔT (temperature rise, difference between surface temperature T_s and ambient temperature T_{amb}). The permissible

temperature rise ΔT is specified by the respective manufacturer. For Vishay Roederstein electrolytic capacitors this value is based on IEC 60384-4 and is 3 K in relation to the upper category temperature T_{UC} . Due to the temperature and frequency dependence of the equivalent series resistance R_{ESR} (or the dissipation factor $\tan \delta$) the maximum permissible alternating current is also dependent on the alternating current frequency f . Since the life expectancy of an electrolytic capacitor is considerably determined by its thermal load (permutation model, see section Lifetime), the temperature rise caused by an AC load presents a significant factor of the capacitor's lifetime. The individual lifetime tables show the interrelation between the maximum permissible alternating current I , the ambient temperature T_{amb} , the surface temperature T_s , the alternating current frequency f , as well as the lifetime. (Sections Standard Lifetime Conversion Table and Type Specific Lifetime Conversion Table explain the use of these tables.)

ELECTRICAL STRENGTH OF THE INSULATION

The insulating sleeve can withstand a voltage of at least 1000 V.

INSULATION RESISTANCE OF THE INSULATION

The insulation resistance of the sleeve material is a minimum of 100 M Ω .

CLIMATIC CONDITIONS

For reasons of reliability and due to the temperature dependence of electrical parameters certain limits have to be observed for the climatic conditions. The upper and lower category temperature are considered important climatic conditions for electrolytic capacitors. Furthermore the degree of humidity has to be taken into account. These three values are indicated in coded form in the applicability class and IEG climatic category (see section Climatic and Applicability Categories).

Upper Category Temperature T_{UC}

The use of electrolytic capacitors is subject to specific upper temperature limits. Exceeding these limits may result in early failure of the capacitor. To avoid this, upper category temperatures are fixed which indicate the maximum permissible ambient temperature of the capacitor for continuous operation. The upper category temperature is given with the temperature range value in the datasheets. Sections Maximum Permissible Alternating Current I, AC Rating and Lifetime have shown that the electrolytic capacitor's lifetime and reliability depend considerably on the capacitor's temperature. This is why Vishay recommend using the capacitor at the lowest temperature possible to increase lifetime and reliability. Furthermore, Vishay recommend mounting the electrolytic capacitors inside the units at positions having a low ambient temperature.



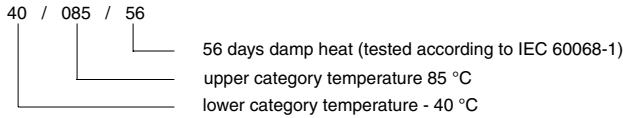
CLIMATIC CONDITIONS (Continued)

Lower Category Temperature T_{LC}

Due to an impaired electrolytic conductivity, a decreasing temperature results in higher values for impedance and dissipation factor (or R_{ESR} values). Most capacitor applications limit such an increase to specific threshold values. For this reason it is practical to stipulate a lower category temperature which is also indicated in the temperature range value given in the datasheet. It should be emphasized, however, that an operation below the specified lower category temperature is possible without damaging the capacitor. This is particularly true if the capacitor is exposed to an alternating-current load. Compared to the lower ambient temperature, the alternating current flowing through the increased equivalent series resistance can heat the electrolytic capacitor to such an extent, that its properties still ensure proper functioning of the unit.

Climatic and Applicability Categories

According to DIN 40040 the applicability class is given in form of a three-letter code. The IEC publication indicates a so-called Category (IEC Climatic Category). The datasheets list both specifications. The first letter in the DIN 40040 formula stands for the lower category temperature, the second for the upper category temperature, and the third for the permissible humidity.



DIN CLIMATIC CATEGORY

1 st letter lower category temperature	F - 55 °C	G - 40 °C	H - 25 °C	
2 nd letter upper category temperature	K 125 °C	M 100 °C (105 °C)	P 85 °C	S 70 °C
3 rd letter relative humidity/ annual average 30 days/year max. occasional formation of dew permissible	C ≤ 95 % 100 % 100 % yes	D ≤ 80 % 100 % 90 % yes	E ≤ 75 % 95 % 85 % yes ⁽¹⁾	F ≤ 75 % 95 % 85 % yes

Note

⁽¹⁾ Rare and mild formation of dew permissible

HOW TO USE ELECTROLYTIC CAPACITORS

Date of Manufacture (Code) IEC 60062

The month and the year of manufacture are indicated. The year is given first, followed by the month.

Code (year)		Code (month)	
2000	M	January	1
2001	N	February	2
2002	P	March	3
2003	R	April	4
2004	S	May	5
2005	T	June	6
2006	U	July	7
2007	V	August	8
2008	W	September	9
2009	X	October	0
2010	A	November	N
2011	B	December	D
2012	C		
2013	D		

Example: 2007 May: V5

Alternatively it is possible to indicate the year and the week. In this case the first two figures indicate the year and the last two the week.

Example: 2003, 20th week: 0320

Pulse Handling

Vishay Roederstein electrolytic capacitors exhibit good pulse handling characteristics. However, due to continuously increased surface gain of anode foils, absolute compliance with the IEC requirement

$$\frac{\Delta C}{C} \leq \pm 10 \% \text{ after } 10^6 \text{ switching cycles}$$

cannot be guaranteed without taking specific measures, which need prior agreement.

Vibration Resistance

If not otherwise indicated in the datasheets, the IEC Publication 60068-2 is applicable: test F_C at 5 g; stress period: 1.5 hours; frequency 10 Hz to 55 Hz, maximum displacement 0.35 mm.

Mounting Position

Care should be taken when mounting capacitors which have a pressure release valve. In vertical mounting the valve should always be at the top to avoid electrolytic leakage if the pressure valve is triggered. Similarly, when mounting the capacitor in a horizontal position the pressure valve should be in the "12- o'clock position".

HOW TO USE ELECTROLYTIC CAPACITORS

(Continued)

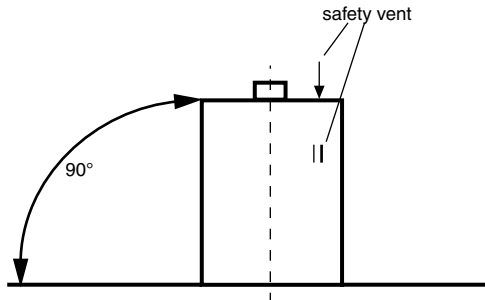


Fig.11 Recommended mounting position

We recommend not to have PC-board traces below radial aluminum electrolytic capacitors.

Low and High Pressure

Vishay Roederstein electrolytic capacitors may be used at any low pressure and at any altitude. The operating temperature should not fall below the lower category temperature. The capacitors may not be used at pressures exceeding 120 kPa.

Cleaning, Moulding

Halogenated hydrocarbons, particularly CFCs (chlorofluorocarbons), are frequently used for the cleaning of boards. There are for instance several FREON types (registered trademark of Du Pont) based on 1,1,1-Trichlorotrifluoroethane.

The manufacturers of aluminum electrolytic capacitors warn against the use of these solvents since a corrosive effect on aluminium is definitely possible. This corrosive mechanism, which may be triggered by the external influence of compounds containing CFCs, is very complex and can lead to consequential changes. Only the strict compliance with a number of clearly defined conditions can provide any protection against the penetration of solvents. We do not consider it necessary to list the conditions here but would advise you against using halogenated compounds for cleaning. Moreover, you should check whether the plastic insulation is resistant to the detergent you want to use. Ketone type solvents (e.g. acetone, methyl ethyl ketone) and ester type solvents (e.g. ethyl acetate, butyl acetate) should preferably not be used or only after checking their effect in the cleaning process. The same applies to aromatic hydrocarbons (e.g. xylenes) and aliphatic hydrocarbons (e.g. petroleum ether).

We recommend using water-based or alcohol-based detergents (e.g. ethanol, isopropanol, isobutyl alcohol, various ethylene glycols, etc.). We also recommend

continuous monitoring of the cleaning bath in order to avoid the accumulation of corrosive agents (e.g. chlorides from solder residues, possibly sulphonates from surface active agents). Careful drying should immediately follow cleaning.

Similar procedures should be observed when electrolytic capacitors are varnished or moulded. Care must be taken that any varnish or moulding components such as resin, hardener, accelerator, thinner, filler, coloring matter, etc. do not contain any halogen.

ELECTROLYTE

The operating electrolyte is an electrically conductive liquid. Its composition differs according to type and voltage range. A polar organic liquid of a high boiling point with a certain amount of salt provides its ionic conductivity. Halogenated hydrocarbons are not used. Water may occur as a constituent of the electrolyte. The salts used can be organic or inorganic.

The electrolytes can be mixed with water. Since they have an almost neutral pH value, there will be no acidic or caustic reaction. Its flash point is always above 80 °C. They do not contain any easily or highly ignitable agents and no explosive substances.

Great attention is given to selecting only those electrolytic constituents that combine the least possible toxicity with the utmost environmental compatibility. Unfortunately the present state of technological development does not always enable us to fully avoid the use of substances which are considered harmful. However, we do not use highly toxic, carcinogenic, or questionable compounds. Extreme care should be taken when handling electrolytic liquid that has leaked out.

- Avoid skin contact
- Do not inhale vapors
- Provide sufficient ventilation

If the electrolyte has come into contact with your skin, mucous membrane, or eyes, immediately rinse carefully for several minutes under running water. Remove affected clothing. Seek medical attention if you have swallowed any liquid.

We would like to remind you that the following errors will trigger the safety mechanism and may result in a discharge of electrolytic fluid:

- reverse polarity
- excessive voltage
- excessive current load
- overheating

DISPOSAL OF USED ALUMINUM ELECTROLYTIC CAPACITORS

Due to potential harmful effects to the environment, special regulations have to be observed which dictate the disposal of capacitors as toxic waste.

Important remarks:

The aluminum electrolytic capacitors do not contain any polychlorinated biphenyls (PCB) or similar substances that may produce dioxins when burning. Moreover, during manufacture we do not use any substances that may harm the ozone layer.

OPERATIONAL RELIABILITY

The specifications regarding the reliability of electrolytic capacitors refer to:

- 1) the failure rate during operation
- 2) the beginning of wear-out failures (end of lifetime)

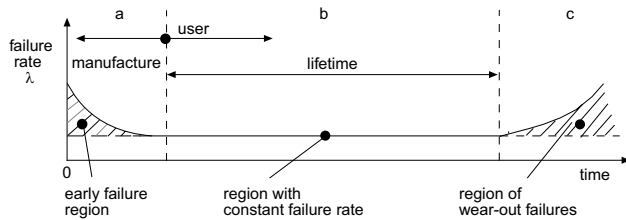


Fig. 12 Failure rate (λ) as a function of time ('bath-tub life curve')

Early failures (region a) of electrolytic capacitors occur during the manufacturing process and are eliminated. We normally expect a constant low failure rate (λ) during the stated lifetime of capacitors (region b). Subsequently the electrolytic capacitors will tend to suffer failures due to drying out (region c).

Endurance Test

IEC 60384-4 and EN 130300 define the criteria for permissible changes in the values of electrical parameters following endurance tests at rated voltage and upper category temperature. The duration and the conditions for the specific capacitor types are given in the respective separate specifications. The endurance test does not allow any direct assessment of the lifetime of an electrolytic capacitor. Therefore the duration of the test must not be confused with the indicated lifetime of the respective capacitor type.

If one of the following conditions is not met, the capacitor has failed the test.

FAILURE CRITERIA FOR ENDURANCE TEST					
CRITERIA	VOLTAGE RANGE	CHANGE IN CAPACITANCE (%)	RATIO OF FINAL VALUE TO SPECIFIED THRESHOLD VALUE		
	V		$\tan \delta$	Z	I_L
A	$6.3 \leq U_R$ $6.3 < U_R \leq 160$ $160 < U_R$	- $40 \leq \Delta C/C \leq + 25$ - $30 \leq \Delta C/C \leq + 30$ - $15 \leq \Delta C/C \leq + 15$	≤ 1.5	≤ 3	≤ 1
B	$6.3 \leq U_R$ $6.3 < U_R \leq 160$ $160 < U_R$	- $30 \leq \Delta C/C \leq + 15$ - $15 \leq \Delta C/C \leq + 15$ - $10 \leq \Delta C/C \leq + 10$	≤ 1.3	≤ 2	≤ 1
C	$16 \leq U_R$ $16 > U_R$	- $25 \leq \Delta C/C \leq + 25$ - $20 \leq \Delta C/C \leq + 20$	≤ 1.5 ≤ 1.5	- -	≤ 1
D		- $20 \leq \Delta C/C \leq + 20$	≤ 2	≤ 2	≤ 1
E		- $15 \leq \Delta C/C \leq + 15$	≤ 1.5	≤ 2	≤ 1
F		- $20 \leq \Delta C/C \leq + 20$	≤ 2	-	≤ 1
G		- $20 \leq \Delta C/C \leq + 20$	≤ 1.5	-	≤ 1

OPERATIONAL RELIABILITY (Continued)

Lifetime

The lifetime is defined as the period during which a specified failure rate is not exceeded under given operating conditions and under specified failure criteria. The indicated lifetime usually is based on a 60 % upper confidence level.

The lifetime is continuously confirmed by accelerated sample tests at the upper category temperature. At temperatures > 40 °C for every temperature rise of 10K the acceleration factor for electrolytic capacitors is assumed to halve the lifetime at the same failure rate (10K rule).

In principle, the lifetime is determined by the loss of electrolyte. The degree of electrolyte loss (diffusion through the sealing elements) depends on the time, the electrolytic vapor pressure, the individual interaction of electrolytic solvent with the sealing materials and geometric factors.

For practical purposes, the temperature dependence is described by way of an equation which was used by Arrhenius to describe the effect of temperature on the rate of chemical reactions. The frequently used 10K rule only provides a practical approximation formula for usual temperature range.

Failure Criteria for Lifetime Indication

Based on IEC 60384-4 or EN1300300, the indicated lifetime values are defined as follows:

- a) load factors
 - rated voltage U_R
 - rated alternating current I_R
 - upper category temperature T_{UC}
- b) failure criteria

FAILURE	PARAMETER	LL GRADE (LONG)	GP GRADE
complete	all	short circuit or break	
change failure	$\tan \delta$ or R_{ESR}	> 3 x initial threshold value	
	I_L	> initial threshold value	
	Z	> 3 x initial threshold value	
	$\Delta C/C$	> ± 30 %	> ± 40 %

The ratio between complete failure and change failure should be 1:9

Failure Rate

The failure rate λ (fit = failure time) is defined as the quotient of the number of failures, and the product of the number of test components and the test period (component operating time).

$$\lambda = \frac{\text{number of failures}}{\text{number of test components} \times \text{test period}}$$

The failure rate provides the basis for reliability forecasts. Usually the failure rate is given with the unit $10^{-9}/h = 1$ fit

(failure in time) at an UCL (Upper Confidence Level) of 60 %. The failure rates indicated apply to $T_{amb} = 40$ °C $U_B = 0.5 \times U_R$. The failure rate is temperature and voltage dependent. The conversion table given below shall be used in the case of other conditions.

Load Voltage

RATED VOLTAGE LOAD	CONVERSION FACTOR
100 %	2.0
75 %	1.4
50 %	1.0
25 %	0.8
10 %	0.6

TEMPERATURE	CONVERSION FACTOR
≤ 40 °C	1
55 °C	3
70 °C	8
85 °C	20
105 °C	90
125 °C	360

Cumulative Failure Frequency

The share of failed components during a stress period (to be specified).



STANDARD LIFETIME CONVERSION TABLE

The lifetime conversion table is used to describe the relation between user current, ambient temperature and lifetime at various frequencies. It should be used to determine lifetime under the conditions in the application. The following

standard table applies to all types where no specific conversion table has been integrated in the datasheet. The table indicates minimum values.

STANDARD LIFETIME CONVERSION TABLE																				
For all surface mount and radial series																				
I/I _R (FREQUENCY DEPENDENT)						Surface temperature rise ΔT _s (°C)	LIFETIME MULTIPLIER L (depending on I/I _R and T _{amb})													
FREQUENCY (Hz)							AMBIENT TEMPERATURE T _{amb} (°C)													
50	100	250	500	1000	> 2500		T _{UC} - 85	T _{UC} - 75	T _{UC} - 65	T _{UC} - 55	T _{UC} - 45	T _{UC} - 40	T _{UC} - 35	T _{UC} - 30	T _{UC} - 25	T _{UC} - 20	T _{UC} - 15	T _{UC} - 10	T _{UC} - 5	T _{UC}
0.2	0.2	0.2	0.2	0.2	0.2	0.1	596	298	149	75	37	26	19	13	9.3	6.6	4.7	3.3	2.33	1.65
0.4	0.4	0.4	0.4	0.4	0.5	0.5	560	280	140	70	35	25	18	12	8.8	6.2	4.4	3.1	2.19	1.55
0.6	0.6	0.6	0.6	0.7	0.7	1.2	505	252	126	63	32	22	16	11	7.9	5.6	3.9	2.8	1.97	1.39
0.7	0.8	0.8	0.9	0.9	0.9	2.1	437	218	109	55	27	19	14	9.6	6.8	4.8	3.4	2.4	1.71	1.21
0.9	1.0	1.1	1.1	1.1	1.2	3.3	362	181	91	45	23	16	11	8.0	5.7	4.0	2.8	2.0	1.41	1.00
1.1	1.2	1.3	1.3	1.3	1.4	4.8	288	144	72	36	18	13	9.0	6.4	4.5	3.2	2.3	1.6	1.13	
1.3	1.4	1.5	1.5	1.6	1.6	6.5	220	110	55	27	14	9.7	6.9	4.9	3.4	2.4	1.7	1.2		
1.5	1.6	1.7	1.7	1.8	1.9	8.4	161	80	40	20	10	7.1	5.0	3.6	2.5	1.8	1.3			
1.7	1.8	1.9	1.9	2.0	2.1	11	113	56	28	14	7.1	5.0	3.5	2.5	1.8	1.2				
1.9	2.0	2.1	2.2	2.2	2.3	13	76	38	19	9.5	4.8	3.4	2.4	1.7	1.2					
2.1	2.2	2.3	2.4	2.5	2.6	16	49	25	12	6.1	3.1	2.2	1.5	1.1						
2.2	2.4	2.5	2.6	2.7	2.8	19	30	15	7.6	3.8	1.9	1.3								
2.4	2.6	2.7	2.8	2.9	3.0	22	18	9.1	4.5	2.3	1.1									
2.6	2.8	2.9	3.0	3.1	3.3	26	10	5.2	2.6	1.3										
2.8	3.0	3.2	3.2	3.3	3.5	30	5.7	2.8	1.4											
3.0	3.2	3.4	3.5	3.6	3.7	34	3.0	1.5												
3.2	3.4	3.6	3.7	3.8	4.0	38	1.5													

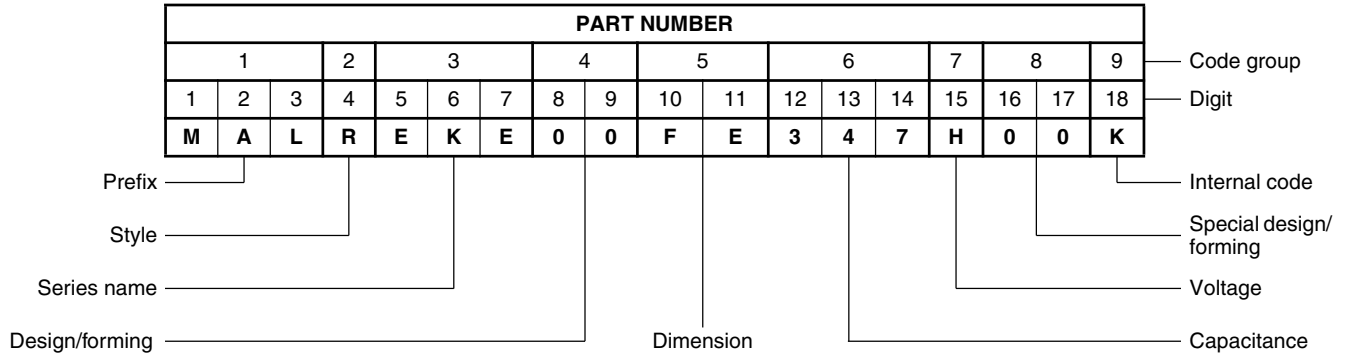
Notes

- T_{UC} upper category temperature (°C)
- I user current (A)
- I_R 100 Hz alternating current (A) at upper category temperature T_{UC} taken from respective datasheet.
- T_{amb} ambient temperature of electrolytic capacitor (°C)
- ΔT_s surface temperature rise of electrolytic capacitor due to user current (°C)
- L lifetime multiplier

combination
not
permitted



PRODUCT CODE



Code Group 1

Consists of three characters which indicate the Aluminum Capacitor Division (Material Aluminum).

Code Group 2

Consists of one character which indicates the style of the product.

- A = Axial
- I = Snap In
- L = Solder Lug
- P = Solder Pin
- R = Radial
- S = SMD
- T = Screw Terminal
- M = Accessories

Code Group 3

Consists of three characters which provide the code indicating the respective series.

Examples of series codes:

EKA, EKB, EKF, EKE, ELM, EBM, EB, EL, EYH, EYN, ECA, ECV

Note

- For two letter type-codes the third place (7th digit) is a zero.

Code Group 4

Consists of two digits which provide the numerical code for specifying a particular design.

Description:

8th digit:

- 0 = Standard design, polarized
- 2 = Bipolar, non-polarized
- 9 = Special, customized

9th digit:

- 0 = Standard design
- 3 = Mounting ring (for axial products only)
- 5 = Cut leads (for radial products only), wires cut to 4.5 mm (3 mm and 4 mm on request)
- 6 = Radial types with Snap-In leads and shortened (for diameter 10 ≤ Ø D ≤ 18 mm only)
- 7 = Radial types with Snap-In pins
- 8 = Radial types with Snap-In pins
- 9 = Radial types, with Snap-In leads, shortened and bent open to 5.0 mm (for diameter Ø D ≤ 8 mm only)



PRODUCT CODE (continued)

Consists of two letters indicating the capacitor's (nominal) dimensions. The 10th digit stands for the diameter D and the 11th for the length L.

Code Group 5

RADIAL TYPES	
10 th digit D(mm)	11 th digit L (mm)
3 = N	5 = P
4 = M	7 = M
5 = A	9 = Z
6.3 = B	10 = V
8 = P	11 = A
8.5 = C	11.5 = B
10 = D	12 = T
12.5 = F	12.5 = C
13 = G	16 = D
14 = H	20 = E
16 = J	22 = F
18 = K	25 = G
22 = L	27 = N
25 = P	30 = J
25.4 = R	31.5 = S
	35 = U
	35.5 = L
	36.5 = R
	41 = K
	45 = W
	51 = X

AXIAL TYPES	
10 th digit D (mm)	11 th digit L (mm)
3.3 = A	7 = M
4.5 = B	8 = N
6 = C	10 = K
6.5 = D	11 = A
8 = F	17 = B
10 = G	18 = L
12 = H	20 = C
14 = J	25 = D
16 = K	30 = E
18 = L	35 = F
21 = M	40 = G
25 = N	45 = H
30 = P	50 = J

CAN TYPES	
10 th digit D (mm)	11 th digit L (mm)
20 = S	20 = W
22 = L	25 = U
25 = A	30 = V
30 = B	35 = A
35 = C	40 = B
40 = D	45 = C
45 = M	50 = D
50 = E	55 = E
55 = F	60 = F
60 = G	65 = H
65 = H	70 = G
76 = K	80 = J
	90 = K
	105 = M
	114 = O
	120 = P
	125 = R
	135 = S
	144 = T
	166 = X

SMD	
10, 11 th digit D x L (mm)	
AA = 3 x 5.3	
BA = 3 x 5.8	
BB = 4 x 5.3	
AB = 4 x 5.8	
BC = 5 x 5.3	
AC = 5 x 5.8	
BD = 6.3 x 5.3	
AD = 6.3 x 5.8	
BM = 6.3 x 7.7	
AE = 8 x 6.5	
AF = 8 x 10	
AG = 10 x 10	
AH = 12.5 x 13.5	
BH = 12.5 x 16.5	
AK = 16 x 16.5	
AM = 16 x 21.5	
AN = 18 x 16.5	
AP = 18 x 21.5	

Code Group 6

Consists of three digits which indicate the capacitance values.

12th digit: Number of place before the decimal point
 13th and 14th digit: Capacitance value

Example:

047 = 0.47 μ F	347 = 470 μ F
147 = 4.7 μ F	447 = 4700 μ F
247 = 47 μ F	547 = 47 000 μ F

Code Group 7

Consists of one place (15th place) and provides the letter code indicating the capacitor's rated DC voltage (V).

A	B	C	D	Z	E	F	G	H	U	J	W	L	M	S	N	V	O	K	R	X	P	Y
4	6.3	10	16	33	25	35	40	50	60	63	80	100	160	200	250	300	350	360	385	400	450	500

**PRODUCT CODE** (continued)**Code Group 8**

Consists of two figures (16th and 17th place) which indicate the capacitance tolerances and special designs.

Description:

16th and 17th digit:

DIN IEC 62 coding:

00 = Standard design

02 = Standard design for can types (pin length 6.3 mm)

03 = Lead length 3.0 mm (in combination with code group 4 only)

04 = Lead length 4.0 mm (in combination with code group 4 only)

05 = Capacitance tolerance - 10 % ... + 50 %

T

06 = Capacitance tolerance - 10 % ... + 30 %

Q

07 = Capacitance tolerance \pm 10 %

K

08 = Capacitance tolerance \pm 15 %

09 = Capacitance tolerance \pm 20 %

M

Note:

- 05 or 09 is only mentioned if there is a deviation of the standard tolerance

10 to 99 = Other special designs

The 16th digit can also be taken by a letter which in this case indicates the type of packaging.

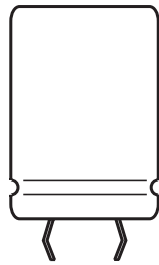
Description:

LETTER CODE	STYLE	CASE DIAMETER (mm)	TYPE OF PACKAGING	LEAD SPACING (mm)
A	Axial	$3.3 \leq 16$	Reel	N/A
B	Axial	$3.3 \leq 16$	Ammo	N/A
M	Radial	$3 \leq 6.3$	Ammo	2.5
N	Radial	8	Ammo	3.5
L	Radial	$4 \leq 8$	Ammo	5.0
G	Radial	$10 \leq 12.5$	Ammo	5.0
G	Radial	$16 \leq 18$	Ammo	7.5

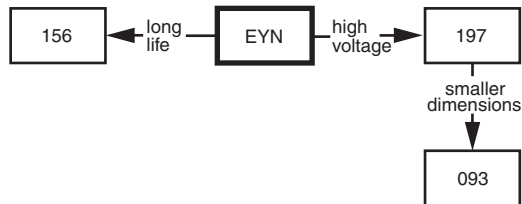
Code Group 9

Consists of one character (18th digit) and is reserved for an internal coding.
(e.g. production line, production location, etc.)

Aluminum Capacitors Standard - 85 °C Snap-In



Component Outline



FEATURES

- Polarized aluminium electrolytic capacitors
- Small dimension
- High C x U product



RoHS
COMPLIANT

APPLICATIONS

- General purpose audio/video systems, industrial electronics
- Smoothing and filtering
- Standard and switch mode power supplies

QUICK REFERENCE DATA		
DESCRIPTION	UNIT	VALUE
Nominal case size (Ø D x L in mm)	mm	22 x 25 to 40 x 60
Rated capacitance range, C _R	µF	1200 to 100 000
Capacitance tolerance	%	± 20
Rated voltage range, U _R	V	6.3 to 100
Category temperature range	°C	- 40 to + 85
Load life at 85 °C	h	2000
Shelf life at 0 V, 85 °C	h	1000
Based on sectional specification		IEC 60384-4/EN 130 300
Climatic category IEC 60068		40/85/56

SELECTION CHART FOR C _R , U _R AND RELEVANT NOMINAL CASE SIZES (Ø D x L in mm)									
C _R (µF)	U _R (V)								
	6.3	10	16	25	35	50	63	80	100
1200	-	-	-	-	-	-	-	22 x 25	22 x 30 25 x 25
1500	-	-	-	-	-	-	-	22 x 30	22 x 35 25 x 30 30 x 25
1800	-	-	-	-	-	-	22 x 25	22 x 30 25 x 25	22 x 40 25 x 35 30 x 30
2200	-	-	-	-	-	-	22 x 30 25 x 25	22 x 35 25 x 30 30 x 25	22 x 45 25 x 40 30 x 30
2700	-	-	-	-	-	-	22 x 35 25 x 30	22 x 40 25 x 35 30 x 30	25 x 45 30 x 35 35 x 30
3300	-	-	-	-	-	22 x 30 25 x 25	22 x 35 25 x 30 30 x 25	22 x 45 25 x 40 30 x 30	25 x 50 30 x 40 35 x 35

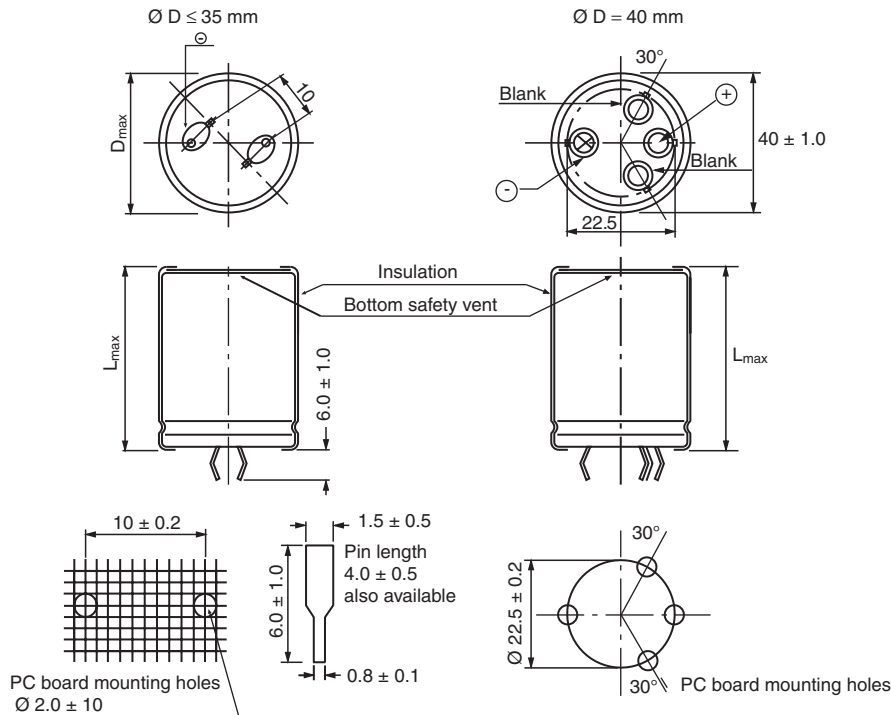


Aluminum Capacitors
Standard - 85 °C Snap-In

Vishay Roederstein

SELECTION CHART FOR C_R, U_R AND RELEVANT NOMINAL CASE SIZES (∅ D x L in mm)									
C _R (µF)	U _R (V)								
	6.3	10	16	25	35	50	63	80	100
3900	-	-	-	-	-	-	22 x 40 25 x 35 30 x 30	22 x 50 25 x 45 30 x 35	30 x 45 35 x 35
4700	-	-	-	-	22 x 30 25 x 25	22 x 40 25 x 35 30 x 25 35 x 25	22 x 50 25 x 40 30 x 35 35 x 30	25 x 50 30 x 40 35 x 30	30 x 50 35 x 40
5600	-	-	-	22 x 25	22 x 35 25 x 30	22 x 45 25 x 40 30 x 30 35 x 25	25 x 45 30 x 35 35 x 30	30 x 45 35 x 35	35 x 45 40 x 40
6800	-	-	-	22 x 30 25 x 25	22 x 40 25 x 30 30 x 25	22 x 50 25 x 40 30 x 35 35 x 30	25 x 50 30 x 40 35 x 30	35 x 40	40 x 50
8200	-	-	-	22 x 35 25 x 30	22 x 45 25 x 35 30 x 30	25 x 50 30 x 40 35 x 30	30 x 45 35 x 35	35 x 45 40 x 40	40 x 50
10 000	-	-	22 x 25	22 x 40 25 x 30 30 x 25	22 x 50 25 x 40 30 x 30	30 x 45 35 x 35	30 x 50 35 x 40	40 x 50	-
12 000	-	22 x 25	22 x 30 25 x 25	22 x 45 25 x 35 30 x 30	25 x 45 30 x 35 35 x 30	30 x 50 35 x 40	35 x 45 40 x 40	-	-
15 000	-	22 x 30 25 x 25	22 x 35 25 x 30 30 x 25	22 x 50 25 x 40 30 x 35	30 x 40 35 x 35	35 x 45	-	-	-
18 000	22 x 30 25 x 25	22 x 35 25 x 25	22 x 40 25 x 35 30 x 30	25 x 45 30 x 35 35 x 30	30 x 45 35 x 40	35 x 50 40 x 40	-	-	-
22 000	22 x 35	22 x 40 25 x 30 30 x 25	22 x 50 25 x 40 30 x 30	30 x 45 35 x 35	35 x 45 40 x 40	40 x 50	-	-	-
27 000	22 x 40 30 x 25	22 x 45 25 x 35 30 x 30	25 x 45 30 x 35	30 x 50 35 x 40	40 x 50	40 x 60	-	-	-
33 000	22 x 45 25 x 35 30 x 30	22 x 50 25 x 40 35 x 25	30 x 40 35 x 30	35 x 45 40 x 40	40 x 50	-	-	-	-
39 000	22 x 50 25 x 40 35 x 25	25 x 45 30 x 25	30 x 45	-	-	-	-	-	-
47 000	30 x 35 35 x 30	25 x 50 30 x 40	30 x 50 35 x 40	-	-	-	-	-	-
56 000	30 x 40 35 x 30	30 x 45	40 x 40	-	-	-	-	-	-
68 000	-	-	35 x 50	-	-	-	-	-	-
100 000	40 x 40	40 x 50	40 x 60	-	-	-	-	-	-

DIMENSIONS in millimeters **AND AVAILABLE FORMS**



DIMENSIONS in millimeters MASS AND PACKAGING QUANTITIES			
NOMINAL CASE SIZE $\varnothing D \times L$	MAXIMUM SIZE $\varnothing D_{max} \times L_{max}$	MASS (g)	PACKAGING QUANTITIES (units per box)
22 x 25	23 x 27	14	200
22 x 30	23 x 32	16	
22 x 35	23 x 37	19	
22 x 40	23 x 42	22	
22 x 45	23 x 47	24	
22 x 50	23 x 52	27	
25 x 25	26.4 x 27	10	150
25 x 30	26.4 x 32	21	
25 x 35	26.4 x 37	25	
25 x 40	26.4 x 42	28	
25 x 45	26.4 x 47	31	
25 x 50	26.4 x 52	35	
30 x 25	31 x 27	25	100
30 x 30	31 x 32	30	
30 x 35	31 x 37	35	
30 x 40	31 x 42	40	
30 x 45	31 x 47	45	
30 x 50	31 x 52	50	
35 x 25	36 x 27	34	50
35 x 30	36 x 32	41	
35 x 35	36 x 37	48	
35 x 40	36 x 42	55	
35 x 45	36 x 47	62	
35 x 50	36 x 52	68	
40 x 40	41 x 42	72	50
40 x 50	41 x 52	89	
40 x 60	41 x 62	107	



Aluminum Capacitors
Standard - 85 °C Snap-In

Vishay Roederstein

ELECTRICAL DATA	
SYMBOL	DESCRIPTION
C _R	rated capacitance at 120 Hz
U _R	rated voltage
ESR	equivalent series resistance at 120 Hz
I _R	rated RMS ripple current at 120 Hz, 85 °C

ORDERING EXAMPLE

Electrolytic capacitor EYN series

4700 µF/35 V; ± 20 %
Nominal case size: 22 mm x 30 mm
snap-in pin 4 mm, fully insulated

Ordering code: MALIEYN07LV447F42K

Note

- Unless otherwise specified, all electrical values apply at
T_{amb} = 20 °C, P = 80 kPa to 120 kPa, RH = 45 % to 75 %

ELECTRICAL DATA AND ORDERING INFORMATION							
U _R (V)	C _R 120 Hz (µF)	NOMINAL CASE SIZE Ø D x L (mm)	I _R 120 Hz (A)	I _{L5} (µA)	ESR 120 Hz MAX. (Ω)	ORDERING CODE 6 mm PIN LENGTH	ORDERING CODE 4 mm PIN LENGTH
6.3	18 000	22 x 30	3.85	1010	0.033	MALIEYN07LV518B02K	MALIEYN07LV518B42K
	18 000	25 x 25	3.96	1010	0.033	MALIEYN07AU518B02K	MALIEYN07AU518B42K
	22 000	22 x 35	4.34	1117	0.030	MALIEYN07LA522B02K	MALIEYN07LA522B42K
	27 000	22 x 40	4.85	1237	0.027	MALIEYN07LB527B02K	MALIEYN07LB527B42K
	27 000	30 x 25	4.89	1237	0.027	MALIEYN07BU527B02K	MALIEYN07BU527B42K
	33 000	22 x 45	5.36	1368	0.024	MALIEYN07LC533B02K	MALIEYN07LC533B42K
	33 000	25 x 35	5.32	1368	0.024	MALIEYN07AA533B02K	MALIEYN07AA533B42K
	33 000	30 x 30	5.47	1368	0.024	MALIEYN07BV533B02K	MALIEYN07BV533B42K
	39 000	22 x 50	5.83	1487	0.022	MALIEYN07LD539B02K	MALIEYN07LD539B42K
	39 000	25 x 40	5.82	1487	0.022	MALIEYN07AB539B02K	MALIEYN07AB539B42K
	39 000	35 x 25	5.82	1487	0.022	MALIEYN07CU539B02K	MALIEYN07CU539B42K
	47 000	30 x 35	6.26	1632	0.021	MALIEYN07BA547B02K	MALIEYN07BA547B42K
	47 000	35 x 30	6.41	1632	0.021	MALIEYN07CV547B02K	MALIEYN07CV547B42K
	56 000	30 x 40	6.80	1782	0.020	MALIEYN07BB556B02K	MALIEYN07BB556B42K
	56 000	35 x 30	6.64	1782	0.020	MALIEYN07CV556B02K	MALIEYN07CV556B42K
		100 000	40 x 40	8.49	2381	0.017	MALIEYN07DB610B02K
10	12 000	22 x 25	3.31	1039	0.044	MALIEYN07LU512C02K	MALIEYN07LU512C42K
	15 000	22 x 30	3.82	1162	0.038	MALIEYN07LV515C02K	MALIEYN07LV515C42K
	15 000	25 x 25	3.39	1162	0.038	MALIEYN07AU515C02K	MALIEYN07AU515C42K
	18 000	22 x 35	4.28	1273	0.034	MALIEYN07LA518C02K	MALIEYN07LA518C42K
	18 000	25 x 25	4.17	1273	0.034	MALIEYN07AU518C02K	MALIEYN07AU518C42K
	22 000	22 x 40	4.79	1407	0.030	MALIEYN07LB522C02K	MALIEYN07LB522C42K
	22 000	25 x 30	4.71	1407	0.030	MALIEYN07AV522C02K	MALIEYN07AV522C42K
	22 000	30 x 25	4.83	1407	0.030	MALIEYN07BU522C02K	MALIEYN07BU522C42K
	27 000	22 x 45	5.30	1559	0.027	MALIEYN07LC527C02K	MALIEYN07LC527C42K
	27 000	25 x 35	5.26	1559	0.027	MALIEYN07AA527C02K	MALIEYN07AA527C42K
	27 000	30 x 30	5.41	1559	0.027	MALIEYN07BV527C02K	MALIEYN07BV527C42K
	33 000	22 x 50	5.82	1723	0.025	MALIEYN07LD533C02K	MALIEYN07LD533C42K
	33 000	25 x 40	5.81	1723	0.025	MALIEYN07AB533C02K	MALIEYN07AB533C42K
	33 000	35 x 25	5.81	1723	0.025	MALIEYN07CU533C02K	MALIEYN07CU533C42K
	39 000	25 x 45	6.31	1873	0.023	MALIEYN07AC539C02K	MALIEYN07AC539C42K
	39 000	35 x 30	6.38	1873	0.023	MALIEYN07CV539C02K	MALIEYN07CV539C42K
	39 000	30 x 35	6.22	1873	0.023	MALIEYN07BA539C02K	MALIEYN07BA539C42K
	47 000	25 x 50	6.83	2057	0.021	MALIEYN07AD547C02K	MALIEYN07AD547C42K
	47 000	30 x 40	6.78	2057	0.021	MALIEYN07BB547C02K	MALIEYN07BB547C42K
	56 000	30 x 45	7.31	2245	0.020	MALIEYN07BC556C02K	MALIEYN07BC556C42K
	100 000	40 x 50	9.35	3000	0.017	MALIEYN07DD610C02K	MALIEYN07DD610C42K
16	10 000	22 x 25	3.32	949	0.046	MALIEYN07LU510D02K	MALIEYN07LU510D42K
	12 000	22 x 30	3.55	1039	0.041	MALIEYN07LV512D02K	MALIEYN07LV512D42K
	12 000	25 x 25	3.89	1039	0.041	MALIEYN07AU512D02K	MALIEYN07AU512D42K
	15 000	22 x 35	4.29	1162	0.035	MALIEYN07LA515D02K	MALIEYN07LA515D42K

ELECTRICAL DATA AND ORDERING INFORMATION							
U _R (V)	C _R 120 Hz (μF)	NOMINAL CASE SIZE Ø D x L (mm)	I _R 120 Hz (A)	I _{L5} (μA)	ESR 120 Hz MAX. (Ω)	ORDERING CODE 6 mm PIN LENGTH	ORDERING CODE 4 mm PIN LENGTH
16	15 000	25 x 30	4.45	1162	0.035	MALIEYN07AV515D02K	MALIEYN07AV515D42K
	15 000	30 x 25	4.56	1162	0.035	MALIEYN07BU515D02K	MALIEYN07BU515D42K
	18 000	22 x 40	4.77	1273	0.032	MALIEYN07LB518D02K	MALIEYN07LB518D42K
	18 000	25 x 35	4.96	1273	0.032	MALIEYN07AA518D02K	MALIEYN07AA518D42K
	18 000	30 x 30	5.10	1273	0.032	MALIEYN07BV518D02K	MALIEYN07BV518D42K
	22 000	22 x 50	5.51	1407	0.028	MALIEYN07LD522D02K	MALIEYN07LD522D42K
	22 000	25 x 40	5.51	1407	0.028	MALIEYN07AB522D02K	MALIEYN07AB522D42K
	22 000	30 x 30	5.39	1407	0.028	MALIEYN07BV522D02K	MALIEYN07BV522D42K
	27 000	25 x 45	6.06	1559	0.026	MALIEYN07AC527D02K	MALIEYN07AC527D42K
	27 000	30 x 35	5.98	1972	0.026	MALIEYN07BA527D02K	MALIEYN07BA527D42K
	33 000	30 x 40	6.56	2180	0.023	MALIEYN07BB533D02K	MALIEYN07BB533D42K
	33 000	35 x 30	6.41	2180	0.023	MALIEYN07CV533D02K	MALIEYN07CV533D42K
	39 000	30 x 45	7.08	2370	0.022	MALIEYN07BC539D02K	MALIEYN07BC539D42K
	47 000	30 x 50	7.62	2602	0.020	MALIEYN07BD547D02K	MALIEYN07BD547D42K
	47 000	35 x 40	7.54	2602	0.020	MALIEYN07CB547D02K	MALIEYN07CB547D42K
	56 000	40 x 40	8.23	2840	0.019	MALIEYN07DB556D02K	MALIEYN07DB556D42K
	68 000	35 x 50	8.63	3129	0.018	MALIEYN07CD568D02K	MALIEYN07CD568D42K
100 000	40 x 60	10.20	3795	0.017	MALIEYN07DF610D02K	MALIEYN07DF610D42K	
25	5600	22 x 25	2.65	898	0.083	MALIEYN07LU456E02K	MALIEYN07LU456E42K
	6800	22 x 30	3.06	990	0.071	MALIEYN07LV468E02K	MALIEYN07LV468E42K
	6800	25 x 25	3.15	990	0.071	MALIEYN07AU468E02K	MALIEYN07AU468E42K
	8200	22 x 35	3.45	1087	0.061	MALIEYN07LA482E02K	MALIEYN07LA482E42K
	8200	25 x 30	3.57	1087	0.061	MALIEYN07AV482E02K	MALIEYN07AV482E42K
	10 000	22 x 40	3.95	1200	0.052	MALIEYN07LB510E02K	MALIEYN07LB510E42K
	10 000	25 x 30	3.89	1200	0.052	MALIEYN07AV510E02K	MALIEYN07AV510E42K
	10 000	30 x 25	3.99	1200	0.052	MALIEYN07BU510E02K	MALIEYN07BU510E42K
	12 000	22 x 45	4.41	1643	0.046	MALIEYN07LC512E02K	MALIEYN07LC512E42K
	12 000	25 x 35	4.37	1643	0.046	MALIEYN07AA512E02K	MALIEYN07AA512E42K
	12 000	30 x 30	4.50	1643	0.046	MALIEYN07BV512E02K	MALIEYN07BV512E42K
	15 000	22 x 50	4.94	1837	0.039	MALIEYN07LD515E02K	MALIEYN07LD515E42K
	15 000	25 x 40	4.94	1837	0.039	MALIEYN07AB515E02K	MALIEYN07AB515E42K
	15 000	30 x 35	5.10	1837	0.039	MALIEYN07BA515E02K	MALIEYN07BA515E42K
	18 000	25 x 45	5.45	2012	0.035	MALIEYN07AC518E02K	MALIEYN07AC518E42K
	18 000	30 x 35	5.38	2012	0.035	MALIEYN07BA518E02K	MALIEYN07BA518E42K
	18 000	35 x 30	5.51	2012	0.035	MALIEYN07CV518E02K	MALIEYN07CV518E42K
	22 000	30 x 45	6.22	2225	0.031	MALIEYN07BC522E02K	MALIEYN07BC522E42K
	22 000	35 x 35	6.12	2225	0.031	MALIEYN07CA522E02K	MALIEYN07CA522E42K
	27 000	30 x 50	6.82	2465	0.028	MALIEYN07BD527E02K	MALIEYN07BD527E42K
27 000	35 x 40	6.74	2465	0.028	MALIEYN07CB527E02K	MALIEYN07CB527E42K	
33 000	35 x 45	7.35	2725	0.025	MALIEYN07CC533E02K	MALIEYN07CC533E42K	
33 000	40 x 40	7.48	2725	0.025	MALIEYN07DB533E02K	MALIEYN07DB533E42K	
35	4700	22 x 30	3.06	1028	0.085	MALIEYN07LV447F02K	MALIEYN07LV447F42K
	4700	25 x 25	2.98	1028	0.085	MALIEYN07AU447F02K	MALIEYN07AU447F42K
	5600	22 x 35	3.28	1122	0.073	MALIEYN07LA456F02K	MALIEYN07LA456F42K
	5600	25 x 30	3.39	1122	0.073	MALIEYN07AV456F02K	MALIEYN07AV456F42K
	6800	22 x 40	3.73	1464	0.063	MALIEYN07LB468F02K	MALIEYN07LB468F42K
	6800	25 x 30	3.67	1464	0.063	MALIEYN07AV468F02K	MALIEYN07AV468F42K
	6800	30 x 25	3.76	1464	0.063	MALIEYN07BU468F02K	MALIEYN07BU468F42K
	8200	22 x 45	4.13	1607	0.054	MALIEYN07LC482F02K	MALIEYN07LC482F42K
	8200	25 x 35	4.10	1607	0.054	MALIEYN07AA482F02K	MALIEYN07AA482F42K
	8200	30 x 30	4.22	1607	0.054	MALIEYN07BV482F02K	MALIEYN07BV482F42K
	10 000	22 x 50	4.68	1775	0.047	MALIEYN07LD510F02K	MALIEYN07LD510F42K
	10 000	25 x 40	4.68	1775	0.047	MALIEYN07AB510F02K	MALIEYN07AB510F42K



Aluminum Capacitors
Standard - 85 °C Snap-In

Vishay Roederstein

ELECTRICAL DATA AND ORDERING INFORMATION							
U _R (V)	C _R 120 Hz (μF)	NOMINAL CASE SIZE Ø D x L (mm)	I _R 120 Hz (A)	I _{L5} (μA)	ESR 120 Hz MAX. (Ω)	ORDERING CODE 6 mm PIN LENGTH	ORDERING CODE 4 mm PIN LENGTH
35	10 000	30 x 30	4.58	1775	0.047	MALIEYN07BV510F02K	MALIEYN07BV510F42K
	12 000	25 x 45	5.18	1944	0.041	MALIEYN07AC512F02K	MALIEYN07AC512F42K
	12 000	30 x 35	5.11	1944	0.041	MALIEYN07BA512F02K	MALIEYN07BA512F42K
	12 000	35 x 30	5.24	1944	0.041	MALIEYN07CV512F02K	MALIEYN07CV512F42K
	15 000	30 x 40	5.72	2174	0.036	MALIEYN07BB515F02K	MALIEYN07BB515F42K
	15 000	35 x 35	5.88	2174	0.036	MALIEYN07CA515F02K	MALIEYN07CA515F42K
	18 000	30 x 45	6.28	2381	0.032	MALIEYN07BC518F02K	MALIEYN07BC518F42K
	18 000	35 x 40	6.46	2381	0.032	MALIEYN07CB518F02K	MALIEYN07CB518F42K
	22 000	35 x 45	7.07	2632	0.029	MALIEYN07CC522F02K	MALIEYN07CC522F42K
	22 000	40 x 40	7.20	2632	0.029	MALIEYN07DB522F02K	MALIEYN07DB522F42K
	27 000	40 x 50	8.14	2916	0.026	MALIEYN07DD527F02K	MALIEYN07DD527F42K
	33 000	40 x 50	8.46	3224	0.023	MALIEYN07DD533F02K	MALIEYN07DD533F42K
50	3300	22 x 30	2.97	1020	0.100	MALIEYN07LV433H02K	MALIEYN07LV433H42K
	3300	25 x 25	3.06	1020	0.100	MALIEYN07AU433H02K	MALIEYN07AU433H42K
	4700	22 x 40	3.83	1217	0.074	MALIEYN07LB447H02K	MALIEYN07LB447H42K
	4700	25 x 35	3.98	1217	0.074	MALIEYN07AA447H02K	MALIEYN07AA447H42K
	4700	30 x 25	3.86	1454	0.074	MALIEYN07BU447H02K	MALIEYN07BU447H42K
	4700	35 x 25	4.19	1454	0.074	MALIEYN07CU447H02K	MALIEYN07CU447H42K
	5600	22 x 45	4.26	1587	0.065	MALIEYN07LC456H02K	MALIEYN07LC456H42K
	5600	25 x 40	4.44	1587	0.065	MALIEYN07AB456H02K	MALIEYN07AB456H42K
	5600	30 x 30	4.35	1587	0.065	MALIEYN07BV456H02K	MALIEYN07BV456H42K
	5600	35 x 25	4.44	1587	0.065	MALIEYN07CU456H02K	MALIEYN07CU456H42K
	6800	22 x 50	4.77	1749	0.056	MALIEYN07LD468H02K	MALIEYN07LD468H42K
	6800	25 x 40	4.76	1749	0.056	MALIEYN07AB468H02K	MALIEYN07AB468H42K
	6800	30 x 35	4.92	1749	0.056	MALIEYN07BA468H02K	MALIEYN07BA468H42K
	6800	35 x 30	5.04	1749	0.056	MALIEYN07CV468H02K	MALIEYN07CV468H42K
	8200	25 x 50	5.43	1921	0.048	MALIEYN07AD482H02K	MALIEYN07AD482H42K
	8200	30 x 40	5.38	1921	0.048	MALIEYN07BB482H02K	MALIEYN07BB482H42K
	8200	35 x 30	5.26	1921	0.048	MALIEYN07CV482H02K	MALIEYN07CV482H42K
	10 000	30 x 45	6.07	2121	0.042	MALIEYN07BC510H02K	MALIEYN07BC510H42K
	10 000	35 x 35	5.97	2121	0.042	MALIEYN07CA510H02K	MALIEYN07CA510H42K
	12 000	30 x 50	6.62	2324	0.037	MALIEYN07BD512H02K	MALIEYN07BD512H42K
	12 000	35 x 40	6.55	2324	0.037	MALIEYN07CB512H02K	MALIEYN07CB512H42K
	15 000	35 x 45	7.20	2598	0.032	MALIEYN07CC515H02K	MALIEYN07CC515H42K
	18 000	35 x 50	7.74	2846	0.029	MALIEYN07CD518H02K	MALIEYN07CD518H42K
	18 000	40 x 40	7.62	2846	0.029	MALIEYN07DB518H02K	MALIEYN07DB518H42K
	22 000	40 x 50	8.54	3146	0.026	MALIEYN07DD522H02K	MALIEYN07DD522H42K
	27 000	40 x 60	9.45	3486	0.024	MALIEYN07DF527H02K	MALIEYN07DF527H42K
	63	1800	22 x 25	2.20	900	0.184	MALIEYN07LU418J02K
2200		22 x 30	2.50	995	0.153	MALIEYN07LV422J02K	MALIEYN07LV422J42K
2200		25 x 25	2.58	995	0.153	MALIEYN07AU422J02K	MALIEYN07AU422J42K
2700		22 x 35	2.94	1102	0.127	MALIEYN07LA427J02K	MALIEYN07LA427J42K
2700		25 x 30	3.04	1237	0.127	MALIEYN07AV427J02K	MALIEYN07AV427J42K
3300		22 x 35	3.14	1368	0.107	MALIEYN07LA433J02K	MALIEYN07LA433J42K
3300		25 x 30	3.26	1368	0.107	MALIEYN07AV433J02K	MALIEYN07AV433J42K
3300		30 x 25	3.34	1368	0.107	MALIEYN07BU433J02K	MALIEYN07BU433J42K
3900		22 x 40	3.60	1487	0.092	MALIEYN07LB439J02K	MALIEYN07LB439J42K
3900		25 x 35	3.74	1487	0.092	MALIEYN07AA439J02K	MALIEYN07AA439J42K
3900		30 x 30	3.85	1487	0.092	MALIEYN07BV439J02K	MALIEYN07BV439J42K
4700		22 x 50	4.19	1632	0.079	MALIEYN07LD447J02K	MALIEYN07LD447J42K
4700		25 x 40	4.19	1632	0.079	MALIEYN07AB447J02K	MALIEYN07AB447J42K
4700		30 x 35	4.10	1632	0.079	MALIEYN07BA447J02K	MALIEYN07BA447J42K
4700		35 x 30	4.19	1632	0.079	MALIEYN07CV447J02K	MALIEYN07CV447J42K

ELECTRICAL DATA AND ORDERING INFORMATION

U _R (V)	C _R 120 Hz (μF)	NOMINAL CASE SIZE Ø D x L (mm)	I _R 120 Hz (A)	I _{L5} (μA)	ESR 120 Hz MAX. (Ω)	ORDERING CODE 6 mm PIN LENGTH	ORDERING CODE 4 mm PIN LENGTH
63	5600	25 x 45	4.65	1782	0.068	MALIEYN07AC456J02K	MALIEYN07AC456J42K
	5600	30 x 35	4.58	1782	0.068	MALIEYN07BA456J02K	MALIEYN07BA456J42K
	5600	35 x 30	4.70	1782	0.068	MALIEYN07CV456J02K	MALIEYN07CV456J42K
	6800	25 x 50	5.20	1964	0.059	MALIEYN07AD468J02K	MALIEYN07AD468J42K
	6800	30 x 40	5.16	1964	0.059	MALIEYN07BB468J02K	MALIEYN07BB468J42K
	6800	35 x 30	5.04	1964	0.059	MALIEYN07CV468J02K	MALIEYN07CV468J42K
	8200	30 x 45	5.62	2156	0.051	MALIEYN07BC482J02K	MALIEYN07BC482J42K
	8200	35 x 35	5.53	2156	0.051	MALIEYN07CA482J02K	MALIEYN07CA482J42K
	10 000	30 x 50	6.32	2381	0.044	MALIEYN07BD510J02K	MALIEYN07BD510J42K
	10 000	35 x 40	6.25	2381	0.044	MALIEYN07CB510J02K	MALIEYN07CB510J42K
	12 000	35 x 45	6.83	2608	0.039	MALIEYN07CC512J02K	MALIEYN07CC512J42K
	12 000	40 x 40	6.95	2608	0.039	MALIEYN07DB512J02K	MALIEYN07DB512J42K
80	1200	22 x 25	2.24	825	0.221	MALIEYN07LU412W02K	MALIEYN07LU412W42K
	1500	22 x 30	2.67	1039	0.179	MALIEYN07LV415W02K	MALIEYN07LV415W42K
	1800	22 x 30	2.92	1138	0.152	MALIEYN07LV418W02K	MALIEYN07LV418W42K
	1800	25 x 25	3.01	1138	0.152	MALIEYN07AU418W02K	MALIEYN07AU418W42K
	2200	22 x 35	3.25	1259	0.127	MALIEYN07LA422W02K	MALIEYN07LA422W42K
	2200	25 x 30	3.36	1259	0.127	MALIEYN07AV422W02K	MALIEYN07AV422W42K
	2200	30 x 25	3.45	1259	0.127	MALIEYN07BU422W02K	MALIEYN07BU422W42K
	2700	22 x 40	3.79	1394	0.106	MALIEYN07LB427W02K	MALIEYN07LB427W42K
	2700	25 x 35	3.94	1394	0.106	MALIEYN07AA427W02K	MALIEYN07AA427W42K
	2700	30 x 30	4.05	1394	0.106	MALIEYN07BV427W02K	MALIEYN07BV427W42K
	3300	22 x 45	4.18	1541	0.089	MALIEYN07LC433W02K	MALIEYN07LC433W42K
	3300	25 x 40	4.36	1541	0.089	MALIEYN07AB433W02K	MALIEYN07AB433W42K
	3300	30 x 30	4.27	1541	0.089	MALIEYN07BV433W02K	MALIEYN07BV433W42K
	3900	22 x 50	4.75	1676	0.077	MALIEYN07LD439W02K	MALIEYN07LD439W42K
	3900	25 x 45	4.96	1676	0.077	MALIEYN07AC439W02K	MALIEYN07AC439W42K
	3900	30 x 35	4.89	1676	0.077	MALIEYN07BA439W02K	MALIEYN07BA439W42K
	4700	25 x 50	5.44	1840	0.066	MALIEYN07AD447W02K	MALIEYN07AD447W42K
	4700	30 x 40	5.39	1840	0.066	MALIEYN07BB447W02K	MALIEYN07BB447W42K
	4700	35 x 30	5.27	1840	0.066	MALIEYN07CV447W02K	MALIEYN07CV447W42K
	5600	30 x 45	5.91	2008	0.058	MALIEYN07BC456W02K	MALIEYN07BC456W42K
	5600	35 x 35	5.81	2008	0.058	MALIEYN07CA456W02K	MALIEYN07CA456W42K
	6800	35 x 40	5.46	2213	0.050	MALIEYN07CB468W02K	MALIEYN07CB468W42K
	8200	35 x 45	6.91	2430	0.044	MALIEYN07CC482W02K	MALIEYN07CC482W42K
	8200	40 x 40	7.04	2430	0.044	MALIEYN07DB482W02K	MALIEYN07DB482W42K
10 000	40 x 50	8.14	2683	0.038	MALIEYN07DD510W02K	MALIEYN07DD510W42K	
100	1200	22 x 30	2.39	930	0.221	MALIEYN07LV412L02K	MALIEYN07LV412L42K
	1200	25 x 25	2.46	930	0.221	MALIEYN07AU412L02K	MALIEYN07AU412L42K
	1500	22 x 35	2.83	1039	0.179	MALIEYN07LA415L02K	MALIEYN07LA415L42K
	1500	25 x 30	2.93	1039	0.179	MALIEYN07AV415L02K	MALIEYN07AV415L42K
	1500	30 x 25	3.00	1039	0.179	MALIEYN07BU415L02K	MALIEYN07BU415L42K
	1800	22 x 40	3.26	1138	0.152	MALIEYN07LB418L02K	MALIEYN07LB418L42K
	1800	25 x 35	3.39	1138	0.152	MALIEYN07AA418L02K	MALIEYN07AA418L42K
	1800	30 x 30	3.49	1138	0.152	MALIEYN07BV418L02K	MALIEYN07BV418L42K
	2200	22 x 45	3.58	1259	0.127	MALIEYN07LC422L02K	MALIEYN07LC422L42K
	2200	25 x 40	3.74	1259	0.127	MALIEYN07AB422L02K	MALIEYN07AB422L42K
	2200	30 x 30	3.66	1259	0.127	MALIEYN07BV422L02K	MALIEYN07BV422L42K
	2700	25 x 45	4.33	1394	0.106	MALIEYN07AC427L02K	MALIEYN07AC427L42K
	2700	30 x 35	4.27	1394	0.106	MALIEYN07BA427L02K	MALIEYN07BA427L42K
	2700	35 x 30	4.37	1394	0.106	MALIEYN07CV427L02K	MALIEYN07CV427L42K
	3300	25 x 50	4.76	1541	0.089	MALIEYN07AD433L02K	MALIEYN07AD433L42K
	3300	30 x 40	4.72	1541	0.089	MALIEYN07BB433L02K	MALIEYN07BB433L42K



Aluminum Capacitors
Standard - 85 °C Snap-In

Vishay Roederstein

ELECTRICAL DATA AND ORDERING INFORMATION							
U _R (V)	C _R 120 Hz (μF)	NOMINAL CASE SIZE Ø D x L (mm)	I _R 120 Hz (A)	I _{L5} (μA)	ESR 120 Hz MAX. (Ω)	ORDERING CODE 6 mm PIN LENGTH	ORDERING CODE 4 mm PIN LENGTH
100	3300	35 x 35	4.85	1541	0.089	MALIEYN07CA433L02K	MALIEYN07CA433L42K
	3900	30 x 45	5.36	1676	0.077	MALIEYN07BC439L02K	MALIEYN07BC439L42K
	3900	35 x 35	5.27	1676	0.077	MALIEYN07CA439L02K	MALIEYN07CA439L42K
	4700	30 x 50	5.86	1840	0.066	MALIEYN07BD447L02K	MALIEYN07BD447L42K
	4700	35 x 40	5.80	1840	0.066	MALIEYN07CB447L02K	MALIEYN07CB447L42K
	5600	35 x 45	6.34	2008	0.058	MALIEYN07CC456L02K	MALIEYN07CC456L42K
	5600	40 x 40	6.45	2008	0.058	MALIEYN07DB456L02K	MALIEYN07DB456L42K
	6800	40 x 50	7.40	2213	0.050	MALIEYN07DD468L02K	MALIEYN07DD468L42K
	8200	40 x 50	7.60	2430	0.044	MALIEYN07DD482L02K	MALIEYN07DD482L42K

LOW TEMPERATURE BEHAVIOR

Table for the calculation of the maximum 10 kHz impedance at low temperatures:

$$Z(10 \text{ kHz})[\Omega] = \frac{\text{Tabular value}}{C_R[\mu\text{F}]}$$

T _{amb} (°C)	RATED VOLTAGE U _R (V)														
	6.3	10	16	25	35	50	63	100	160	200	250	350	400	450	500
25	9000	7200	5400	4050	3150	2700	2250	1710	1960	1820	1680	1870	1870	1870	1870
40	30 000	24 000	18 000	13 500	10 500	12 000	10 000	7600	7000	6500	7200	6600	-	-	-

The lower limit of the series resistance and impedance is given by the ohmic part of the contact points and the foil resistance values. Therefore it will not always be possible to achieve calculated values below 0.03 Ω.

LIFETIME TABLE U_R ≤ 100 V

INTERRELATION BETWEEN ALTERNATING CURRENT, AMBIENT TEMPERATURE AND LIFETIME																
I/I _R (FREQUENCY DEPENDANT)							LIFETIME MULTIPLIER L (DEPENDING ON I/I _R AND T _{amb})									
FREQUENCY (Hz)							AMBIENT TEMPERATURE T _{amb} (°C)									
50	100	120	250	500	1000	> 2500	40	45	50	55	60	65	70	75	80	85
0.00	0.00	0.00	0.00	0.00	0.00	0.00	66	42	27	17	11	7.6	5.1	3.5	2.4	1.7
0.17	0.19	0.20	0.22	0.23	0.23	0.24	62	40	26	17	11	7.4	5.0	3.4	2.3	1.6
0.34	0.39	0.40	0.43	0.45	0.46	0.47	53	34	22	15	9.9	6.7	4.5	3.1	2.2	1.5
0.51	0.58	0.60	0.65	0.68	0.70	0.71	43	28	19	12	8.4	5.8	4.0	2.8	1.9	1.4
0.68	0.78	0.80	0.86	0.90	0.93	0.94	32	22	15	10	6.9	4.8	3.4	2.4	1.7	1.2
0.85	0.97	1.00	1.08	1.13	1.16	1.18	23	16	11	7.8	5.5	3.8	2.7	1.9	1.4	1.00
1.02	1.17	1.20	1.30	1.35	1.39	1.42	16	12	8.3	5.9	4.2	3.0	2.2	1.6	1.1	
1.20	1.36	1.40	1.51	1.58	1.62	1.65	11	3.3	6.0	4.3	3.1	2.3	1.7	1.2		
1.37	1.56	1.60	1.73	1.81	1.85	1.89	7.7	6.0	4.2	3.1	2.3	1.7	1.3			
1.54	1.75	1.80	1.94	2.03	2.09	2.12	5.1	4.2	2.9	2.2	1.7	1.3				
1.71	1.95	2.00	2.16	2.26	2.32	2.36	3.4	2.9	2.0	1.6	1.2					
1.88	2.14	2.20	2.38	2.48	2.55	2.59	2.2	2.0	1.4	1.1						
2.05	2.34	2.40	2.59	2.71	2.78	2.83	1.5	1.4								
2.22	2.53	2.60	2.81	2.94	3.01	3.07	1.0									

Notes

I_R Rated ripple current (120 Hz, RMS) [A] at upper category temperature T_{uc} taken from datasheet

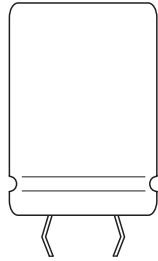
I User ripple current [A]

T_{amb} Ambient temperature of capacitor [°C]

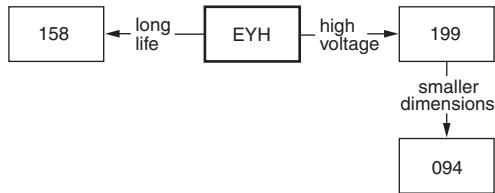
L Useful life multiplier

Regard L as a function of ambient temperature (x-axis) and of current (y-axis); use the current-axis according to the frequency.

Aluminum Capacitors Standard - 105 °C Snap-In



Component Outline



FEATURES

- Polarized aluminum electrolytic capacitors
- Small dimensions
- High C x U product



RoHS
COMPLIANT

APPLICATIONS

- General purpose audio/video systems, industrial electronics, telecommunication
- Smoothing and filtering
- Standard and switch mode power supplies

QUICK REFERENCE DATA		
DESCRIPTION	UNIT	VALUE
Nominal case size (Ø D x L)	mm	22 x 25 to 40 x 60
Rated capacitance range C _R	µF	820 to 68 000
Capacitance tolerance	%	± 20
Rated voltage range, U _R	V	6.3 to 100
Category temperature range	°C	- 40 to + 105
Load life at 105 °C	h	2000
Shelf life at 0 V, 105 °C	h	1000
Based on sectional specifications		IEC 60384-4/EN 130300
Climatic category IEC 60068		40/105/56

SELECTION CHART FOR C _R , U _R AND RELEVANT NOMINAL CASE SIZES (Ø D x L in mm)									
C _R (µF)	U _R (V)								
	6.3	10	16	25	35	50	63	80	100
820	-	-	-	-	-	-	-	22 x 25	22 x 30 25 x 25
1000	-	-	-	-	-	-	-	22 x 30 25 x 25	22 x 35 25 x 30
1200	-	-	-	-	-	-	22 x 25	22 x 30 25 x 25	22 x 40 25 x 35 30 x 25
1500	-	-	-	-	-	-	22 x 30 25 x 25	22 x 35 25 x 30	22 x 45 25 x 40 30 x 30
1800	-	-	-	-	-	-	22 x 30 25 x 25	22 x 40 25 x 35 30 x 25	25 x 45 30 x 35
2200	-	-	-	-	-	-	22 x 35 25 x 30	22 x 45 25 x 35 30 x 30	25 x 50 30 x 40 35 x 30

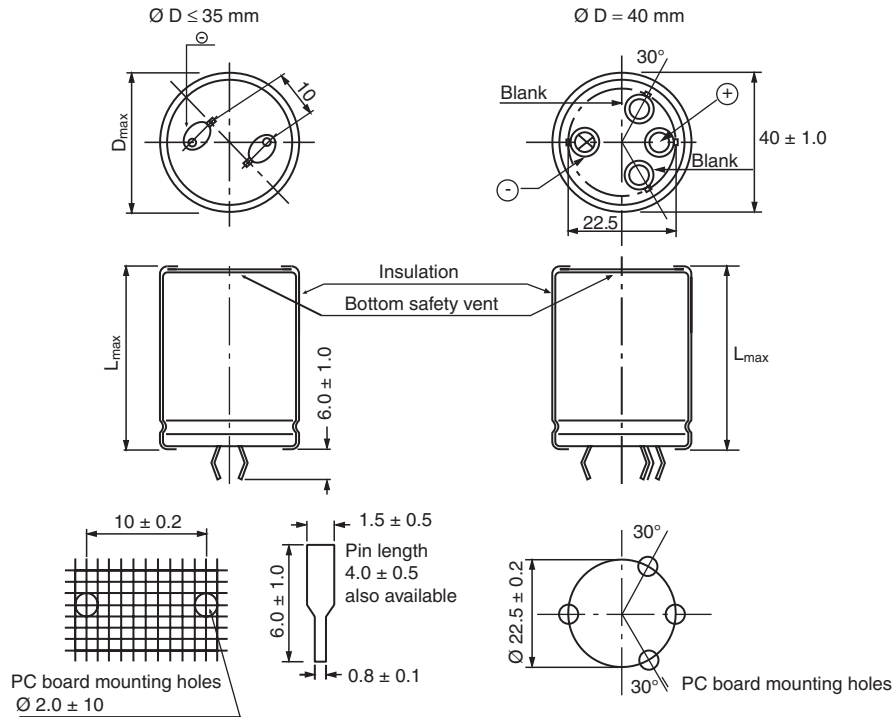


Aluminum Capacitors
Standard - 105 °C Snap-In

Vishay Roederstein

SELECTION CHART FOR C_R, U_R AND RELEVANT NOMINAL CASE SIZES (∅ D x L in mm)									
C _R (µF)	U _R (V)								
	6.3	10	16	25	35	50	63	80	100
2700	-	-	-	-	-	22 x 30	22 x 40 25 x 30 30 x 25	25 x 45 30 x 35	30 x 45 35 x 35
3300	-	-	-	-	22 x 25	22 x 35	22 x 50 25 x 40 30 x 30	25 x 50 30 x 40 35 x 30	30 x 50 35 x 40
3900	-	-	-	-	22 x 30	22 x 40 25 x 35 30 x 25	25 x 45 30 x 35	30 x 45 35 x 35	35 x 45
4700	-	-	-	22 x 25	22 x 35 25 x 25	22 x 45 25 x 40 30 x 30	25 x 50 30 x 40 35 x 30	30 x 50 35 x 40	35 x 50 40 x 40
5600	-	-	-	22 x 30	22 x 35 25 x 30	22 x 50 25 x 40 30 x 35	30 x 45 35 x 35	35 x 45	40 x 50
6800	-	-	-	22 x 30	22 x 40 25 x 35	25 x 50 30 x 40 35 x 30	30 x 50 35 x 40	40 x 40	40 x 50
8200	-	-	22 x 25	22 x 35 25 x 30	22 x 50 25 x 40 30 x 30	30 x 45 35 x 35	35 x 45	40 x 50	-
10 000	-	22 x 25	22 x 30 25 x 25	22 x 40 25 x 35	25 x 45 30 x 30	30 x 50 35 x 40	35 x 50 40 x 40	-	-
12 000	22 x 25	22 x 30	22 x 35 25 x 30 30 x 25	22 x 45 25 x 40 30 x 30	25 x 50 35 x 30	35 x 45	-	-	-
15 000	22 x 30	22 x 35 25 x 25	22 x 40 25 x 35 30 x 30	25 x 45 30 x 35 35 x 30	35 x 35	35 x 50 40 x 40	-	-	-
18 000	22 x 35 25 x 25	22 x 35 25 x 30	22 x 45 25 x 40 30 x 30	25 x 50 30 x 40 35 x 35	35 x 40	40 x 50	-	-	-
22 000	22 x 35 25 x 30	22 x 40 25 x 35 30 x 25	25 x 45 30 x 35	30 x 45 35 x 35	35 x 45 40 x 40	40 x 50	-	-	-
27 000	22 x 40 25 x 35 30 x 25	22 x 50 25 x 40 30 x 30	25 x 50 30 x 40 35 x 30	35 x 45 40 x 40	40 x 50	40 x 60	-	-	-
33 000	22 x 50 25 x 40 30 x 30	25 x 45 30 x 35	30 x 45 35 x 35	-	-	-	-	-	-
39 000	25 x 45 30 x 35	25 x 50 30 x 40 35 x 30	30 x 50 35 x 40	-	-	-	-	-	-
47 000	25 x 50 30 x 40 35 x 30	30 x 45 35 x 35	35 x 45 40 x 40	-	-	-	-	-	-
56 000	30 x 50 35 x 40	35 x 45 40 x 40	40 x 50	-	-	-	-	-	-
68 000	35 x 45 40 x 40	40 x 50	40 x 60	-	-	-	-	-	-

DIMENSIONS in millimeters **AND AVAILABLE FORMS**



DIMENSIONS in millimeters, MASS AND PACKAGING QUANTITIES			
NOMINAL CASE SIZE $\varnothing D \times L$	MAXIMUM SIZE $\varnothing D_{max.} \times L_{max.}$	MASS (g)	PACKAGING QUANTITIES (units per box)
22 x 25	23 x 27	14	200
22 x 30	23 x 32	16	
22 x 35	23 x 37	19	
22 x 40	23 x 42	22	
22 x 45	23 x 47	24	
22 x 50	23 x 52	27	
25 x 25	26.4 x 27	18	150
25 x 30	26.4 x 32	21	
25 x 35	26.4 x 37	25	
25 x 40	26.4 x 42	28	
25 x 45	26.4 x 47	31	
25 x 50	26.4 x 52	35	
30 x 25	31 x 27	25	100
30 x 30	31 x 32	30	
30 x 35	31 x 37	35	
30 x 40	31 x 42	40	
30 x 45	31 x 47	45	
30 x 50	31 x 52	50	
35 x 30	36 x 32	41	50
35 x 35	36 x 37	48	
35 x 40	36 x 42	55	
35 x 45	36 x 47	62	
35 x 50	36 x 52	68	
40 x 40	41 x 42	72	50
40 x 50	41 x 52	89	
40 x 60	41 x 62	106	



Aluminum Capacitors
Standard - 105 °C Snap-In

Vishay Roederstein

ELECTRICAL DATA	
SYMBOL	DESCRIPTION
C _R	rated capacitance at 120 Hz
U _R	rated voltage
ESR	max. equivalent series resistance at 120 Hz
I _R	rated RMS ripple current at 120 Hz, 105 °C
T _{amb}	ambient temperature
RH	relative humidity
P	ambient pressure

ORDERING EXAMPLE

Electrolytic capacitor EYH series

4700 µF/35 V; ± 20 %
Nominal case size: 22 mm x 35 mm
snap-in pin 4 mm, fully insulated.

Ordering code: MALIEYH07LA447F42K

Note

- Unless otherwise specified, all electrical values apply at
T_{amb} = 20 °C, P = 80 kPa to 120 kPa, RH = 45 % to 75 %

ELECTRICAL DATA AND ORDERING INFORMATION							
U _R (V)	C _R 120 Hz (µF)	NOMINAL CASE SIZE D x L (mm)	I _R 120 Hz (A)	I _{LS} (µA)	ESR 120 Hz MAX. (Ω)	ORDERING CODE 6 mm PIN LENGTH	ORDERING CODE 4 mm PIN LENGTH
6.3	12 000	22 x 25	2.19	825	0.055	MALIEYH07LU512B02K	MALIEYH07LU512B42K
	15 000	22 x 30	2.53	922	0.047	MALIEYH07LV515B02K	MALIEYH07LV515B42K
	18 000	22 x 35	2.85	1010	0.041	MALIEYH07LA518B02K	MALIEYH07LA518B42K
	18 000	25 x 25	2.77	1010	0.041	MALIEYH07AU518B02K	MALIEYH07AU518B42K
	22 000	22 x 35	3.04	1117	0.036	MALIEYH07LA522B02K	MALIEYH07LA522B42K
	22 000	25 x 30	3.15	1117	0.036	MALIEYH07AV522B02K	MALIEYH07AV522B42K
	27 000	22 x 40	3.40	1237	0.032	MALIEYH07LB527B02K	MALIEYH07LB527B42K
	27 000	25 x 35	3.53	1237	0.032	MALIEYH07AA527B02K	MALIEYH07AA527B42K
	27 000	30 x 25	3.42	1237	0.032	MALIEYH07BU527B02K	MALIEYH07BU527B42K
	33 000	22 x 50	3.92	1368	0.029	MALIEYH07LD533B02K	MALIEYH07LD533B42K
	33 000	25 x 40	3.91	1368	0.029	MALIEYH07AB533B02K	MALIEYH07AB533B42K
	33 000	30 x 30	3.83	1368	0.029	MALIEYH07BV533B02K	MALIEYH07BV533B42K
	39 000	25 x 45	4.26	1487	0.026	MALIEYH07AC539B02K	MALIEYH07AC539B42K
	39 000	30 x 35	4.20	1487	0.026	MALIEYH07BA539B02K	MALIEYH07BA539B42K
	47 000	25 x 50	4.63	1632	0.024	MALIEYH07AD547B02K	MALIEYH07AD547B42K
	47 000	30 x 40	4.60	1632	0.024	MALIEYH07BB547B02K	MALIEYH07BB547B42K
	47 000	35 x 30	4.50	1632	0.024	MALIEYH07CV547B02K	MALIEYH07CV547B42K
	56 000	30 x 50	5.17	1782	0.022	MALIEYH07BD556B02K	MALIEYH07BD556B42K
56 000	35 x 40	5.12	1782	0.022	MALIEYH07CB556B02K	MALIEYH07CB556B42K	
68 000	35 x 45	5.52	1964	0.021	MALIEYH07CC568B02K	MALIEYH07CC568B42K	
68 000	40 x 40	5.62	1964	0.021	MALIEYH07DB568B02K	MALIEYH07DB568B42K	
10	10 000	22 x 25	2.17	949	0.066	MALIEYH07LU510C02K	MALIEYH07LU510C42K
	12 000	22 x 30	2.48	1039	0.057	MALIEYH07LV512C02K	MALIEYH07LV512C42K
	15 000	22 x 35	2.83	1162	0.049	MALIEYH07LA515C02K	MALIEYH07LA515C42K
	15 000	25 x 25	2.75	1162	0.049	MALIEYH07AU515C02K	MALIEYH07AU515C42K
	18 000	22 x 35	3.00	1273	0.043	MALIEYH07LA518C02K	MALIEYH07LA518C42K
	18 000	25 x 30	3.11	1273	0.043	MALIEYH07AV518C02K	MALIEYH07AV518C42K
	22 000	22 x 40	3.35	1407	0.037	MALIEYH07LB522C02K	MALIEYH07LB522C42K
	22 000	25 x 35	3.48	1407	0.037	MALIEYH07AA522C02K	MALIEYH07AA522C42K
	22 000	30 x 25	3.38	1407	0.037	MALIEYH07BU522C02K	MALIEYH07BU522C42K
	27 000	22 x 50	3.88	1559	0.033	MALIEYH07LD527C02K	MALIEYH07LD527C42K
	27 000	25 x 40	3.87	1559	0.033	MALIEYH07AB527C02K	MALIEYH07AB527C42K
	27 000	30 x 30	3.79	1559	0.033	MALIEYH07BV527C02K	MALIEYH07BV527C42K

ELECTRICAL DATA AND ORDERING INFORMATION

U_R (V)	C_R 120 Hz (μ F)	NOMINAL CASE SIZE D x L (mm)	I_R 120 Hz (A)	I_{L5} (μ A)	ESR 120 Hz MAX. (Ω)	ORDERING CODE 6 mm PIN LENGTH	ORDERING CODE 4 mm PIN LENGTH
10	33 000	25 x 45	4.26	1723	0.029	MALIEYH07AC533C02K	MALIEYH07AC533C42K
	33 000	30 x 35	4.20	1723	0.029	MALIEYH07BA533C02K	MALIEYH07BA533C42K
	39 000	25 x 50	4.60	1873	0.027	MALIEYH07AD539C02K	MALIEYH07AD539C42K
	39 000	30 x 40	4.57	1873	0.027	MALIEYH07BB539C02K	MALIEYH07BB539C42K
	39 000	35 x 30	4.46	1873	0.027	MALIEYH07CV539C02K	MALIEYH07CV539C42K
	47 000	30 x 45	4.95	2057	0.025	MALIEYH07BC547C02K	MALIEYH07BC547C42K
	47 000	35 x 35	4.87	2057	0.025	MALIEYH07CA547C02K	MALIEYH07CA547C42K
	56 000	35 x 45	5.49	2245	0.023	MALIEYH07CC556C02K	MALIEYH07CC556C42K
	56 000	40 x 40	5.59	2245	0.023	MALIEYH07DB556C02K	MALIEYH07DB556C42K
	68 000	40 x 50	6.22	2474	0.021	MALIEYH07DD568C02K	MALIEYH07DD568C42K
16	8200	22 x 25	2.14	1087	0.065	MALIEYH07LU482D02K	MALIEYH07LU482D42K
	10 000	22 x 30	2.48	1200	0.055	MALIEYH07LV510D02K	MALIEYH07LV510D42K
	10 000	25 x 25	2.56	1200	0.055	MALIEYH07AU510D02K	MALIEYH07AU510D42K
	12 000	22 x 35	2.80	1315	0.048	MALIEYH07LA512D02K	MALIEYH07LA512D42K
	12 000	25 x 30	2.90	1315	0.048	MALIEYH07AV512D02K	MALIEYH07AV512D42K
	12 000	30 x 25	2.97	1315	0.048	MALIEYH07BU512D02K	MALIEYH07BU512D42K
	15 000	22 x 40	3.17	1470	0.041	MALIEYH07LB515D02K	MALIEYH07LB515D42K
	15 000	25 x 35	3.29	1470	0.041	MALIEYH07AA515D02K	MALIEYH07AA515D42K
	15 000	30 x 30	3.38	1470	0.041	MALIEYH07BV515D02K	MALIEYH07BV515D42K
	18 000	22 x 45	3.50	1610	0.037	MALIEYH07LC518D02K	MALIEYH07LC518D42K
	18 000	25 x 40	3.65	1610	0.037	MALIEYH07AB518D02K	MALIEYH07AB518D42K
	18 000	30 x 30	3.57	1610	0.037	MALIEYH07BV518D02K	MALIEYH07BV518D42K
	22 000	25 x 45	4.03	1780	0.032	MALIEYH07AC522D02K	MALIEYH07AC522D42K
	22 000	30 x 35	3.98	1780	0.032	MALIEYH07BA522D02K	MALIEYH07BA522D42K
	27 000	25 x 50	4.42	1972	0.029	MALIEYH07AD527D02K	MALIEYH07AD527D42K
	27 000	30 x 40	4.39	1972	0.029	MALIEYH07BB527D02K	MALIEYH07BB527D42K
	27 000	35 x 30	4.29	1972	0.029	MALIEYH07CV527D02K	MALIEYH07CV527D42K
	33 000	30 x 45	4.79	2180	0.026	MALIEYH07BC533D02K	MALIEYH07BC533D42K
	33 000	35 x 35	4.71	2180	0.026	MALIEYH07CA533D02K	MALIEYH07CA533D42K
	39 000	30 x 50	5.16	2370	0.024	MALIEYH07BD539D02K	MALIEYH07BD539D42K
	39 000	35 x 40	5.10	2370	0.024	MALIEYH07CB539D02K	MALIEYH07CB539D42K
	47 000	35 x 45	5.50	2602	0.022	MALIEYH07CC547D02K	MALIEYH07CC547D42K
	47 000	40 x 40	5.60	2602	0.022	MALIEYH07DB547D02K	MALIEYH07DB547D42K
	56 000	40 x 50	6.22	2840	0.021	MALIEYH07DD556D02K	MALIEYH07DD556D42K
68 000	40 x 60	6.83	3129	0.019	MALIEYH07DF568D02K	MALIEYH07DF568D42K	
25	4700	22 x 25	1.73	1028	0.099	MALIEYH07LU447E02K	MALIEYH07LU447E42K
	5600	22 x 30	1.98	1122	0.085	MALIEYH07LV456E02K	MALIEYH07LV456E42K
	6800	22 x 30	2.14	1237	0.072	MALIEYH07LV468E02K	MALIEYH07LV468E42K
	8200	22 x 35	2.42	1358	0.062	MALIEYH07LA482E02K	MALIEYH07LA482E42K
	8200	25 x 30	2.50	1358	0.062	MALIEYH07AV482E02K	MALIEYH07AV482E42K
	10 000	22 x 40	2.77	1500	0.053	MALIEYH07LB510E02K	MALIEYH07LB510E42K
	10 000	25 x 35	2.88	1500	0.053	MALIEYH07AA510E02K	MALIEYH07AA510E42K
	12 000	22 x 45	3.09	1643	0.047	MALIEYH07LC512E02K	MALIEYH07LC512E42K
	12 000	25 x 40	3.22	1643	0.047	MALIEYH07AB512E02K	MALIEYH07AB512E42K
	12 000	30 x 30	3.15	1643	0.047	MALIEYH07BV512E02K	MALIEYH07BV512E42K
	15 000	25 x 45	3.62	1837	0.040	MALIEYH07AC515E02K	MALIEYH07AC515E42K
	15 000	30 x 35	3.57	1837	0.040	MALIEYH07BA515E02K	MALIEYH07BA515E42K
	15 000	35 x 30	3.65	1837	0.040	MALIEYH07CV515E02K	MALIEYH07CV515E42K
	18 000	25 x 50	3.98	2012	0.036	MALIEYH07AD518E02K	MALIEYH07AD518E42K
	18 000	30 x 40	3.95	2012	0.036	MALIEYH07BB518E02K	MALIEYH07BB518E42K
	18 000	35 x 35	4.06	2012	0.036	MALIEYH07CA518E02K	MALIEYH07CA518E42K
	22 000	30 x 45	4.36	2225	0.032	MALIEYH07BC522E02K	MALIEYH07BC522E42K
	22 000	35 x 35	4.28	2225	0.032	MALIEYH07CA522E02K	MALIEYH07CA522E42K
	27 000	35 x 45	4.92	2465	0.028	MALIEYH07CC527E02K	MALIEYH07CC527E42K
	27 000	40 x 40	5.01	2465	0.028	MALIEYH07DB527E02K	MALIEYH07DB527E42K



Aluminum Capacitors
Standard - 105 °C Snap-In

Vishay Roederstein

ELECTRICAL DATA AND ORDERING INFORMATION							
U _R (V)	C _R 120 Hz (µF)	NOMINAL CASE SIZE D x L (mm)	I _R 120 Hz (A)	I _{L5} (µA)	ESR 120 Hz MAX. (Ω)	ORDERING CODE 6 mm PIN LENGTH	ORDERING CODE 4 mm PIN LENGTH
35	3300	22 x 25	1.62	1020	0.141	MALIEYH07LU433F02K	MALIEYH07LU433F42K
	3900	22 x 30	1.88	1108	0.121	MALIEYH07LV439F02K	MALIEYH07LV439F42K
	4700	22 x 35	2.14	1217	0.103	MALIEYH07LA447F02K	MALIEYH07LA447F42K
	4700	25 x 25	2.09	1217	0.103	MALIEYH07AU447F02K	MALIEYH07AU447F42K
	5600	22 x 35	2.29	1328	0.088	MALIEYH07LA456F02K	MALIEYH07LA456F42K
	5600	25 x 30	2.37	1328	0.088	MALIEYH07AV456F02K	MALIEYH07AV456F42K
	6800	22 x 40	2.61	1464	0.075	MALIEYH07LB468F02K	MALIEYH07LB468F42K
	6800	25 x 35	2.71	1464	0.075	MALIEYH07AA468F02K	MALIEYH07AA468F42K
	8200	22 x 50	3.02	1607	0.065	MALIEYH07LD482F02K	MALIEYH07LD482F42K
	8200	25 x 40	3.02	1607	0.065	MALIEYH07AB482F02K	MALIEYH07AB482F42K
	8200	30 x 30	2.95	1607	0.065	MALIEYH07BV482F02K	MALIEYH07BV482F42K
	10 000	25 x 45	3.43	1775	0.055	MALIEYH07AC510F02K	MALIEYH07AC510F42K
	10 000	30 x 30	3.38	1775	0.055	MALIEYH07BV510F02K	MALIEYH07BV510F42K
	12 000	25 x 50	3.78	1944	0.048	MALIEYH07AD512F02K	MALIEYH07AD512F42K
	12 000	35 x 30	3.67	1944	0.048	MALIEYH07CV512F02K	MALIEYH07CV512F42K
	15 000	35 x 35	4.12	2174	0.041	MALIEYH07CA515F02K	MALIEYH07CA515F42K
	18 000	35 x 40	4.52	2381	0.037	MALIEYH07CB518F02K	MALIEYH07CB518F42K
22 000	35 x 45	4.95	2632	0.032	MALIEYH07CC522F02K	MALIEYH07CC522F42K	
22 000	40 x 40	5.04	2632	0.032	MALIEYH07DB522F02K	MALIEYH07DB522F42K	
27 000	40 x 50	5.92	2916	0.029	MALIEYH07DD527F02K	MALIEYH07DD527F42K	
50	2700	22 x 30	1.94	1102	0.123	MALIEYH07LV427H02K	MALIEYH07LV427H42K
	3300	22 x 35	2.20	1219	0.103	MALIEYH07LA433H02K	MALIEYH07LA433H42K
	3900	22 x 40	2.52	1325	0.089	MALIEYH07LB439H02K	MALIEYH07LB439H42K
	3900	25 x 35	2.62	1325	0.089	MALIEYH07AA439H02K	MALIEYH07AA439H42K
	3900	30 x 25	2.54	1325	0.089	MALIEYH07BU439H02K	MALIEYH07BU439H42K
	4700	22 x 45	2.81	1454	0.076	MALIEYH07LC447H02K	MALIEYH07LC447H42K
	4700	25 x 40	2.93	1454	0.076	MALIEYH07AB447H02K	MALIEYH07AB447H42K
	4700	30 x 30	2.87	1454	0.076	MALIEYH07BV447H02K	MALIEYH07BV447H42K
	5600	22 x 50	3.11	1587	0.066	MALIEYH07LD456H02K	MALIEYH07LD456H42K
	5600	25 x 40	3.11	1587	0.066	MALIEYH07AB456H02K	MALIEYH07AB456H42K
	5600	30 x 35	3.21	1587	0.066	MALIEYH07BA456H02K	MALIEYH07BA456H42K
	6800	25 x 50	3.64	1749	0.057	MALIEYH07AD468H02K	MALIEYH07AD468H42K
	6800	30 x 40	3.61	1749	0.057	MALIEYH07BB468H02K	MALIEYH07BB468H42K
	6800	35 x 30	3.53	1749	0.057	MALIEYH07CV468H02K	MALIEYH07CV468H42K
	8200	30 x 45	3.94	1921	0.049	MALIEYH07BC482H02K	MALIEYH07BC482H42K
	8200	35 x 35	3.87	1921	0.049	MALIEYH07CA482H02K	MALIEYH07CA482H42K
	10 000	30 x 50	4.42	2121	0.043	MALIEYH07BD510H02K	MALIEYH07BD510H42K
	10 000	35 x 40	4.37	2121	0.043	MALIEYH07CB510H02K	MALIEYH07CB510H42K
	12 000	35 x 45	4.78	2324	0.038	MALIEYH07CC512H02K	MALIEYH07CC512H42K
15 000	35 x 50	5.24	2598	0.033	MALIEYH07CD515H02K	MALIEYH07CD515H42K	
15 000	40 x 40	5.13	2598	0.033	MALIEYH07DB515H02K	MALIEYH07DB515H42K	
18 000	40 x 50	5.76	2846	0.030	MALIEYH07DD518H02K	MALIEYH07DD518H42K	
22 000	40 x 50	5.98	3146	0.027	MALIEYH07DD522H02K	MALIEYH07DD522H42K	
27 000	40 x 60	6.61	3486	0.024	MALIEYH07DF527H02K	MALIEYH07DF527H42K	
63	1200	22 x 25	1.37	825	0.276	MALIEYH07LU412J02K	MALIEYH07LU412J42K
	1500	22 x 30	1.50	922	0.224	MALIEYH07LV415J02K	MALIEYH07LV415J42K
	1500	25 x 25	1.54	922	0.224	MALIEYH07AU415J02K	MALIEYH07AU415J42K
	1800	22 x 30	1.64	1010	0.189	MALIEYH07LV418J02K	MALIEYH07LV418J42K
	1800	25 x 25	1.69	1010	0.189	MALIEYH07AU418J02K	MALIEYH07AU418J42K
	2200	22 x 35	1.86	1117	0.157	MALIEYH07LA422J02K	MALIEYH07LA422J42K
	2200	25 x 30	1.92	1117	0.157	MALIEYH07AV422J02K	MALIEYH07AV422J42K
	2700	22 x 40	2.17	1237	0.130	MALIEYH07LB427J02K	MALIEYH07LB427J42K
	2700	25 x 30	2.13	1237	0.130	MALIEYH07AV427J02K	MALIEYH07AV427J42K
	2700	30 x 25	2.18	1237	0.130	MALIEYH07BU427J02K	MALIEYH07BU427J42K

ELECTRICAL DATA AND ORDERING INFORMATION							
U _R (V)	C _R 120 Hz (μF)	NOMINAL CASE SIZE D x L (mm)	I _R 120 Hz (A)	I _{L5} (μA)	ESR 120 Hz MAX. (Ω)	ORDERING CODE 6 mm PIN LENGTH	ORDERING CODE 4 mm PIN LENGTH
63	3300	22 x 50	2.53	1368	0.109	MALIEYH07LD433J02K	MALIEYH07LD433J42K
	3300	25 x 40	2.53	1368	0.109	MALIEYH07AB433J02K	MALIEYH07AB433J42K
	3300	30 x 30	2.48	1368	0.109	MALIEYH07BV433J02K	MALIEYH07BV433J42K
	3900	25 x 45	2.88	1487	0.094	MALIEYH07AC439J02K	MALIEYH07AC439J42K
	3900	30 x 35	2.84	1487	0.094	MALIEYH07BA439J02K	MALIEYH07BA439J42K
	4700	25 x 50	3.2	1632	0.080	MALIEYH07AD447J02K	MALIEYH07AD447J42K
	4700	30 x 40	3.17	1632	0.080	MALIEYH07BB447J02K	MALIEYH07BB447J42K
	4700	35 x 30	3.10	1632	0.080	MALIEYH07CV447J02K	MALIEYH07CV447J42K
	5600	30 x 45	3.51	1782	0.070	MALIEYH07BC456J02K	MALIEYH07BC456J42K
	5600	35 x 35	3.46	1782	0.070	MALIEYH07CA456J02K	MALIEYH07CA456J42K
	6800	30 x 50	3.92	1964	0.060	MALIEYH07BD468J02K	MALIEYH07BD468J42K
	6800	35 x 40	3.88	1964	0.060	MALIEYH07CB468J02K	MALIEYH07CB468J42K
	8200	35 x 45	4.22	2156	0.052	MALIEYH07CC482J02K	MALIEYH07CC482J42K
	10 000	35 x 50	4.74	2381	0.045	MALIEYH07CD510J02K	MALIEYH07CD510J42K
	10 000	40 x 40	4.64	2381	0.045	MALIEYH07DB510J02K	MALIEYH07DB510J42K
80	820	22 x 25	1.37	768	0.323	MALIEYH07LU382W02K	MALIEYH07LU382W42K
	1000	22 x 30	1.62	849	0.268	MALIEYH07LV410W02K	MALIEYH07LV410W42K
	1000	25 x 25	1.67	849	0.268	MALIEYH07AU410W02K	MALIEYH07AU410W42K
	1200	22 x 30	1.67	930	0.225	MALIEYH07LV412W02K	MALIEYH07LV412W42K
	1200	25 x 25	1.72	930	0.225	MALIEYH07AU412W02K	MALIEYH07AU412W42K
	1500	22 x 35	1.98	1039	0.183	MALIEYH07LA415W02K	MALIEYH07LA415W42K
	1500	25 x 30	2.05	1039	0.183	MALIEYH07AV415W02K	MALIEYH07AV415W42K
	1800	22 x 40	2.28	1138	0.155	MALIEYH07LB418W02K	MALIEYH07LB418W42K
	1800	25 x 35	2.37	1138	0.155	MALIEYH07AA418W02K	MALIEYH07AA418W42K
	1800	30 x 25	2.30	1138	0.155	MALIEYH07BU418W02K	MALIEYH07BU418W42K
	2200	22 x 45	2.51	1259	0.129	MALIEYH07LC422W02K	MALIEYH07LC422W42K
	2200	25 x 35	2.49	1259	0.129	MALIEYH07AA422W02K	MALIEYH07AA422W42K
	2200	30 x 30	2.56	1259	0.129	MALIEYH07BV422W02K	MALIEYH07BV422W42K
	2700	25 x 45	3.03	1394	0.107	MALIEYH07AC427W02K	MALIEYH07AC427W42K
	2700	30 x 35	2.99	1394	0.107	MALIEYH07BA427W02K	MALIEYH07BA427W42K
	3300	25 x 50	3.33	1541	0.090	MALIEYH07AD433W02K	MALIEYH07AD433W42K
	3300	30 x 40	3.30	1541	0.090	MALIEYH07BB433W02K	MALIEYH07BB433W42K
	3300	35 x 30	3.23	1541	0.090	MALIEYH07CV433W02K	MALIEYH07CV433W42K
	3900	30 x 45	3.75	1676	0.078	MALIEYH07BC439W02K	MALIEYH07BC439W42K
	3900	35 x 35	3.69	1676	0.078	MALIEYH07CA439W02K	MALIEYH07CA439W42K
	4700	30 x 50	4.10	1840	0.067	MALIEYH07BD447W02K	MALIEYH07BD447W42K
	4700	35 x 40	4.06	1840	0.067	MALIEYH07CB447W02K	MALIEYH07CB447W42K
5600	35 x 45	4.44	2008	0.059	MALIEYH07CC456W02K	MALIEYH07CC456W42K	
6800	40 x 40	4.80	2213	0.051	MALIEYH07DB468W02K	MALIEYH07DB468W42K	
8200	40 x 50	5.32	2430	0.044	MALIEYH07DD482W02K	MALIEYH07DD482W42K	
100	820	22 x 30	1.16	859	0.323	MALIEYH07LV382L02K	MALIEYH07LV382L42K
	820	25 x 25	1.51	859	0.323	MALIEYH07AU382L02K	MALIEYH07AU382L42K
	1000	22 x 35	1.71	949	0.268	MALIEYH07LA410L02K	MALIEYH07LA410L42K
	1000	25 x 30	1.77	949	0.268	MALIEYH07AV410L02K	MALIEYH07AV410L42K
	1200	22 x 40	1.86	1039	0.225	MALIEYH07LB412L02K	MALIEYH07LB412L42K
	1200	25 x 35	1.94	1039	0.225	MALIEYH07AA412L02K	MALIEYH07AA412L42K
	1200	30 x 25	1.88	1039	0.225	MALIEYH07BU412L02K	MALIEYH07BU412L42K
	1500	22 x 45	2.18	1162	0.183	MALIEYH07LC415L02K	MALIEYH07LC415L42K
	1500	25 x 40	2.28	1162	0.183	MALIEYH07AB415L02K	MALIEYH07AB415L42K
	1500	30 x 30	2.23	1162	0.183	MALIEYH07BV415L02K	MALIEYH07BV415L42K
	1800	25 x 45	2.61	1273	0.155	MALIEYH07AC418L02K	MALIEYH07AC418L42K
	1800	30 x 35	2.57	1273	0.155	MALIEYH07BA418L02K	MALIEYH07BA418L42K
	2200	25 x 50	2.85	1407	0.129	MALIEYH07AD422L02K	MALIEYH07AD422L42K
	2200	30 x 40	2.83	1407	0.129	MALIEYH07BB422L02K	MALIEYH07BB422L42K
	2200	35 x 30	2.76	1407	0.129	MALIEYH07CV422L02K	MALIEYH07CV422L42K



Aluminum Capacitors
Standard - 105 °C Snap-In

Vishay Roederstein

ELECTRICAL DATA AND ORDERING INFORMATION							
U _R (V)	C _R 120 Hz (μF)	NOMINAL CASE SIZE D x L (mm)	I _R 120 Hz (A)	I _{L5} (μA)	ESR 120 Hz MAX. (Ω)	ORDERING CODE 6 mm PIN LENGTH	ORDERING CODE 4 mm PIN LENGTH
100	2700	30 x 45	3.27	1559	0.107	MALIEYH07BC427L02K	MALIEYH07BC427L42K
	2700	35 x 35	3.22	1559	0.107	MALIEYH07CA427L02K	MALIEYH07CA427L42K
	3300	30 x 50	3.59	1723	0.090	MALIEYH07BD433L02K	MALIEYH07BD433L42K
	3300	35 x 40	3.55	1723	0.090	MALIEYH07CB433L02K	MALIEYH07CB433L42K
	3900	35 x 45	4.03	1873	0.078	MALIEYH07CC439L02K	MALIEYH07CC439L42K
	4700	35 x 50	4.40	2057	0.067	MALIEYH07CD447L02K	MALIEYH07CD447L42K
	4700	40 x 40	4.31	2057	0.067	MALIEYH07DB447L02K	MALIEYH07DB447L42K
	5600	40 x 50	4.88	2245	0.059	MALIEYH07DD456L02K	MALIEYH07DD456L42K
	6800	40 x 50	5.18	2474	0.051	MALIEYH07DD468L02K	MALIEYH07DD468L42K

LIFETIME TABLE U_R ≤ 100 V

INTERRELATION BETWEEN ALTERNATING CURRENT, AMBIENT TEMPERATURE AND LIFETIME																				
I/I _R (FREQUENCY DEPENDENT)							LIFETIME MULTIPLIER L (DEPENDING ON I/I _R AND T _{amb})													
FREQUENCY (Hz)							AMBIENT TEMPERATURE T _{amb} (°C)													
50	100	120	250	500	1000	>2500	40	45	50	55	60	65	70	75	80	85	90	95	100	105
0	0	0	0	0	0	0	200	127	81	53	35	23	16	11	7.4	5.1	3.6	2.6	1.84	1.33
0.17	0.20	0.20	0.21	0.22	0.23	0.23	194	123	79	51	34	23	15	10	7.2	5.0	3.5	2.5	1.81	1.31
0.35	0.39	0.40	0.42	0.44	0.46	0.47	177	113	74	48	32	21	14	9.9	6.9	4.8	3.4	2.4	1.73	1.25
0.52	0.59	0.60	0.64	0.66	0.68	0.70	157	101	66	43	29	19	13	9.1	6.3	4.5	3.2	2.3	1.63	1.18
0.70	0.78	0.80	0.85	0.88	0.91	0.94	132	86	57	38	25	17	12	8.2	5.8	4.1	2.9	2.1	1.50	1.09
0.87	0.98	1.00	1.06	1.10	1.14	1.17	108	72	48	32	22	15	10	7.2	5.1	3.6	2.6	1.9	1.36	1.00
1.04	1.17	1.20	1.27	1.32	1.37	1.40	86	58	39	27	18	13	8.9	6.2	4.4	3.2	2.3	1.6	1.20	
1.22	1.37	1.40	1.48	1.54	1.60	1.64	67	46	31	22	15	11	7.4	5.3	3.8	2.7	2.0	1.4	1.05	
1.39	1.56	1.60	1.70	1.76	1.82	1.87	51	35	25	17	12	8.6	6.1	4.4	3.2	2.3	1.7	1.2		
1.57	1.76	1.80	1.91	1.98	2.05	2.11	38	27	19	14	9.7	6.9	5.0	3.6	2.6	1.9	1.4	1.0		
1.74	1.95	2.00	2.12	2.20	2.28	2.34	28	20	15	10	7.6	5.5	4.0	2.9	2.1	1.6	1.2			
1.91	2.15	2.20	2.33	2.42	2.51	2.57	20	15	11	7.9	5.8	4.3	3.1	2.3	1.7	1.3				
2.09	2.34	2.40	2.54	2.64	2.74	2.81	15	11	8.1	6.0	4.4	3.3	2.4	1.8	1.4	1.0				
2.26	2.54	2.60	2.76	2.86	2.96	3.04	11	7.9	5.9	4.4	3.3	2.5	1.9	1.4	1.1					
2.44	2.73	2.80	2.97	3.08	3.19	3.28	7.5	5.7	4.3	3.3	2.5	1.9	1.4	1.1						
2.61	2.93	3.00	3.18	3.30	3.42	3.51	5.3	4.1	3.1	2.4	1.8	1.4	1.1							
2.78	3.12	3.20	3.39	3.52	3.65	3.74	3.7	2.9	2.2	1.7	1.3	1.0								
2.96	3.32	3.40	3.60	3.74	3.88	3.98	2.5	2.0	1.6	1.2	1.0									
3.13	3.51	3.60	3.82	3.96	4.10	4.21	1.8	1.4	1.1											
3.31	3.71	3.80	4.03	4.18	4.33	4.45	1.2	1.0												

Notes

I_R Rated ripple current (120 Hz, RMS) [A] at upper category temperature T_{UC} taken from datasheet

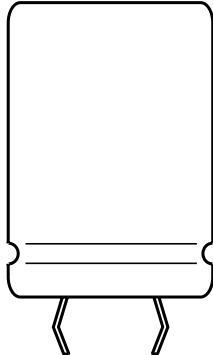
I User ripple current [A]

T_{amb} Ambient temperature of capacitor [°C]

L Lifetime multiplier

Regard L as a function of ambient temperature (x-axis) and of current (y-axis); use the current-axis according to the frequency.

Aluminum Capacitors Power Printed Wiring Style



Component outlines

FEATURES

- Polarized aluminum electrolytic capacitors
- Very small dimensions
- High C x U product
- Charge/discharge proof
- Low impedance, high ripple current capability
- Long useful life: 5000 h to 10 000 h/105 °C



**RoHS
COMPLIANT**

APPLICATIONS

- General purpose, industrial electronics
- Computers, telecommunication, audio/video systems
- Smoothing and filtering
- Standard and switched power supply units
- Energy storage

QUICK REFERENCE DATA

DESCRIPTION	UNIT	≤ 100 V		> 100 V	
		22 x 25 to 35 x 50		22 x 25 to 35 x 60	
Nominal case size (Ø D x L)	mm	22 x 25 to 35 x 50		22 x 25 to 35 x 60	
Rated capacitance range C _R	µF	33 to 47 000		56 to 1800	
Capacitance tolerance	%	± 20			
Rated voltage range	V	10 to 50	63 to 100	200 to 250	400 to 450
Category temperature range	°C	- 40 to + 105			- 25 to + 105
Endurance test at 105 °C	h	2000	5000	2000	
Useful life at 105 °C	h	5000	10 000	5000	
Useful life at 40 °C, 1.9 x I _R applied	h	125 000	250 000	125 000	
Shelf life (0 V, 105 °C)	h	500			1000
Failure rate (0.8 U _R ; 40 °C)	10 ⁻⁹ /h	≤ 50	≤ 25	≤ 100	
Based on sectional specifications		IEC 60384-4/EN130300			
Climatic category IEC 60068		40/105/56			25/105/56

SELECTION CHART FOR C_R, U_R AND RELEVANT NOMINAL CASE SIZES ≤ 100 V (Ø D x L in mm)

C _R (µF)	U _R (V)						
	10	16	25	40	50	63	100
330	-	-	-	-	-	-	22 x 25
470	-	-	-	-	-	-	22 x 30
680	-	-	-	-	-	22 x 25	22 x 40 25 x 30
1000	-	-	-	-	22 x 25	22 x 30	25 x 40 30 x 30
1500	-	-	-	22 x 25	22 x 30	22 x 40 25 x 30	25 x 50 30 x 40
2200	-	-	22 x 25	22 x 30	22 x 40 25 x 30	25 x 40 30 x 30	25 x 50 35 x 40
3300	-	22 x 25	22 x 30	22 x 40 25 x 30	25 x 40 30 x 30	22 x 50 30 x 40	35 x 50
4700	22 x 25	22 x 30	22 x 40 25 x 30	25 x 40 30 x 30	25 x 50 30 x 40	30 x 50 35 x 40	-
6800	22 x 30	22 x 40 25 x 30	25 x 40 30 x 30	25 x 50 30 x 40	30 x 50 35 x 40	35 x 50	-
10 000	22 x 40 25 x 30	25 x 40 30 x 30	22 x 50 30 x 40	30 x 50 35 x 40	35 x 50	-	-
15 000	25 x 40 30 x 30	25 x 50 30 x 40	30 x 50 35 x 40	35 x 50	-	-	-
22 000	25 x 50 30 x 40	30 x 50 35 x 40	35 x 50	-	-	-	-
33 000	30 x 50 35 x 40	35 x 50	-	-	-	-	-
47 000	35 x 50	-	-	-	-	-	-

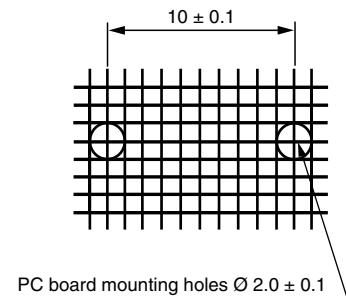
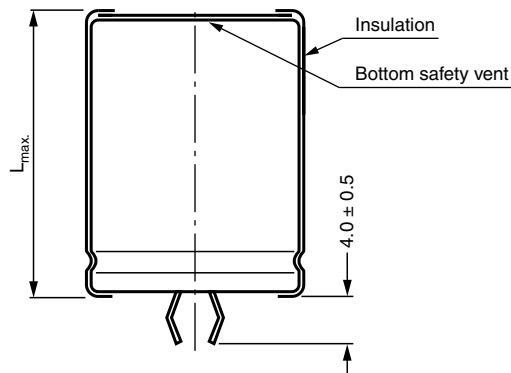
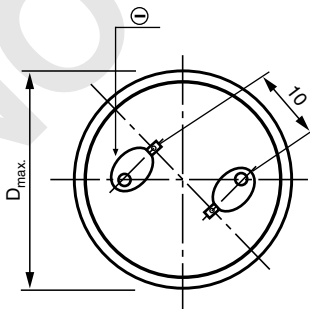
Note

- Special values/dimensions on request

SELECTION CHART FOR C_R, U_R AND RELEVANT NOMINAL CASE SIZES > 100 V ($\varnothing D \times L$ in mm)				
C_R (μF)	U_R (V)			
	200	250	400	450
56	-	-	-	22 x 25
68	-	-	22 x 25	22 x 30 25 x 25
82	-	-	22 x 30 25 x 25	22 x 35
100	-	-	22 x 35 25 x 30	22 x 40 25 x 30 30 x 25
120	-	-	22 x 35 25 x 30 30 x 25	25 x 35
150	-	-	22 x 40 25 x 35 30 x 30	25 x 40 30 x 30 35 x 25
180	-	-	25 x 40 30 x 30 35 x 25	25 x 45 30 x 35
220	-	22 x 30 25 x 25	25 x 45 30 x 35 35 x 30	30 x 40 35 x 30
270	-	22 x 35 25 x 30 30 x 25	25 x 50 30 x 40 35 x 30	30 x 45 35 x 35
330	22 x 30	22 x 40 25 x 30 30 x 25	30 x 45 35 x 35	30 x 50 35 x 40
390	22 x 35 25 x 30 30 x 30	25 x 35 30 x 30 30 x 30	30 x 50 35 x 40	35 x 45
470	22 x 40 30 x 25	25 x 40 30 x 30 35 x 25	35 x 45	35 x 50
560	25 x 35 30 x 30	25 x 45 30 x 35 35 x 30	35 x 50	35 x 60
680	25 x 45 30 x 30 35 x 25	30 x 40 35 x 35	35 x 60	-
820	25 x 50 30 x 35 35 x 30	30 x 45 35 x 35 35 x 40	-	-
1000	30 x 45 35 x 35	35 x 40 35 x 45	-	-
1200	30 x 50 35 x 35	35 x 45 35 x 50	-	-
1500	35 x 45	-	-	-
1800	35 x 50	-	-	-

Note

- Special values/dimensions on request

DIMENSIONS in millimeters AND AVAILABLE FORMS


DIMENSIONS in millimeters, **AND PACKAGING QUANTITIES**

NOMINAL CASE SIZE Ø D x L	MAXIMUM SIZE Ø D _{max.} x L _{max.}	PACKAGING QUANTITY (pieces)
22 x 25	23 x 27	100
22 x 30	23 x 32	
22 x 35	23 x 37	
22 x 40	23 x 42	
25 x 30	26 x 32	
25 x 35	26 x 37	
25 x 40	26 x 42	
25 x 50	26 x 52	
30 x 30	31 x 32	
30 x 35	31 x 37	
30 x 40	31 x 42	
30 x 45	31 x 47	
30 x 50	31 x 52	50
35 x 35	36 x 37	
35 x 40	36 x 42	
35 x 45	36 x 47	
35 x 50	36 x 52	
35 x 60	36 x 62	

ELECTRICAL DATA

SYMBOL	DESCRIPTION
C _R	rated capacitance at 120 Hz
U _R	rated voltage
tan δ	max. dissipation factor at 120 Hz
R _{ESR}	max. equivalent series resistance at 120 Hz
Z	max. impedance at 10 kHz
I _R	rated alternating current (RMS), 120 Hz and upper category temperature
T	ambient temperature
RH	relative humidity
P	ambient pressure

Note

- Unless otherwise specified, all electrical values apply at
T_{amb} = 20 °C, P = 80 kPa to 120 kPa, RH = 45 % to 75 %

ORDERING EXAMPLE

MALIEYC07AB447G02□ = MALIEYC 4700 μF/40 V
25 mm x 40 mm, fully insulated

Length of the snap-in pins: 4 ± 0.5 mm

The 13th place of ordering code refers to the kind of insulation:

MALIEYC07...02 2 = fully insulated

On special request only:

MALIEYC07...01 1 = sleeve insulation

The 14th place (□) is an intercompany code.

ELECTRICAL DATA AND ORDERING INFORMATION

U _R (V)	C _R 120 Hz (μF)	NOMINAL CASE SIZE Ø D x L (mm)	I _R 120 Hz 105 °C (A)	tan δ 120 Hz max.	R _{ESR} 120 Hz max. (Ω)	Z 10 kHz max. (Ω)	WEIGHT (g)	ORDERING CODE
10	4700	22 x 25	1.97	0.28	0.080	0.060	13	MALIEYC07LU447C02□
	6800	22 x 30	2.46	0.30	0.060	0.045	16	MALIEYC07LV468C02□
	10 000	22 x 40	3.32	0.31	0.045	0.035	22	MALIEYC07LB510C02□
	10 000	25 x 30	2.84	0.39	0.055	0.045	21	MALIEYC07AV510C02□
	15 000	25 x 40	3.82	0.41	0.040	0.035	28	MALIEYC07AB515C02□
	15 000	30 x 30	3.57	0.45	0.040	0.035	30	MALIEYC07BV515C02□
	22 000	25 x 50	4.73	0.49	0.030	< 0.030	35	MALIEYC07AD522C02□
	22 000	30 x 40	4.67	0.49	0.030	0.030	41	MALIEYC07BB522C02□
	33 000	30 x 50	5.76	0.57	< 0.030	< 0.030	51	MALIEYC07BD533C02□
	33 000	35 x 40	5.20	0.71	0.030	< 0.030	56	MALIEYC07CB533C02□
	47 000	35 x 50	6.29	0.81	< 0.030	< 0.030	70	MALIEYC07CD547C02□



Aluminum Capacitors
Power Printed Wiring Style

Vishay Roederstein

ELECTRICAL DATA AND ORDERING INFORMATION								
U _R (V)	C _R 120 Hz (μF)	NOMINAL CASE SIZE Ø D x L (mm)	I _R 120 Hz 105 °C (A)	tan δ 120 Hz max.	R _{ESR} 120 Hz max. (Ω)	Z 10 kHz max. (Ω)	WEIGHT (g)	ORDERING CODE
16	3300	22 x 25	1.92	0.20	0.085	0.060	13	MALIEYC07LU433D02□
	4700	22 x 30	2.38	0.22	0.065	0.045	16	MALIEYC07LV447D02□
	6800	22 x 40	3.21	0.22	0.045	0.035	22	MALIEYC07LB468D02□
	6800	25 x 30	2.78	0.27	0.055	0.045	21	MALIEYC07AV468D02□
	10 000	25 x 40	3.70	0.29	0.04	0.035	28	MALIEYC07AB510D02□
	10 000	30 x 30	3.47	0.32	0.045	0.035	30	MALIEYC07BV510D02□
	15 000	25 x 50	4.60	0.34	0.035	< 0.030	35	MALIEYC07AD515D02□
	15 000	30 x 40	4.60	0.34	0.035	0.030	41	MALIEYC07BB515D02□
	22 000	30 x 50	5.73	0.39	< 0.030	< 0.030	51	MALIEYC07BD522D02□
	22 000	35 x 40	5.12	0.49	0.03	< 0.030	56	MALIEYC07CB522D02□
	33 000	35 x 50	6.29	0.59	< 0.030	< 0.030	70	MALIEYC07CD533D02□
25	2200	22 x 25	1.78	0.16	0.100	0.060	13	MALIEYC07LU422E02□
	3300	22 x 30	2.25	0.17	0.070	0.045	16	MALIEYC07LV433E02□
	4700	22 x 40	3.03	0.18	0.055	0.035	22	MALIEYC07LB447E02□
	4700	25 x 30	2.63	0.21	0.060	0.045	21	MALIEYC07AV447E02□
	6800	25 x 40	3.52	0.21	0.045	0.035	28	MALIEYC07AB468E02□
	6800	30 x 30	3.29	0.24	0.05	0.035	30	MALIEYC07BV468E02□
	10 000	25 x 50	4.41	0.25	0.035	< 0.030	35	MALIEYC07AD510E02□
	10 000	30 x 40	4.41	0.25	0.035	0.030	41	MALIEYC07BB510E02□
	15 000	30 x 50	5.48	0.29	0.030	< 0.030	51	MALIEYC07BD515E02□
	15 000	35 x 40	4.96	0.35	0.035	< 0.030	56	MALIEYC07CB515E02□
	22 000	35 x 50	6.13	0.43	0.030	< 0.030	70	MALIEYC07CD522E02□
40	1500	22 x 25	1.67	0.12	0.110	0.070	13	MALIEYC07LU415G02□
	2200	22 x 30	2.06	0.14	0.085	0.055	16	MALIEYC07LV422G02□
	3300	22 x 40	2.81	0.14	0.060	0.040	22	MALIEYC07LB433G02□
	3300	25 x 30	2.45	0.17	0.070	0.050	21	MALIEYC07AV433G02□
	4700	25 x 40	3.29	0.17	0.050	0.035	28	MALIEYC07AB447G02□
	4700	30 x 30	2.99	0.20	0.060	0.045	30	MALIEYC07BV447G02□
	6800	25 x 50	4.14	0.19	0.040	0.030	35	MALIEYC07AD468G02□
	6800	30 x 40	3.98	0.20	0.040	0.030	41	MALIEYC07BB468G02□
	10 000	30 x 50	5.03	0.26	0.035	< 0.030	51	MALIEYC07BD510G02□
	10 000	35 x 40	4.22	0.33	0.045	0.030	56	MALIEYC07CB510G02□
	15 000	35 x 50	5.26	0.39	0.035	< 0.030	70	MALIEYC07CD515G02□
50	1000	22 x 25	1.52	0.10	0.135	0.070	13	MALIEYC07LU410H02□
	1500	22 x 30	1.90	0.11	0.100	0.055	16	MALIEYC07LV415H02□
	2200	22 x 40	2.58	0.11	0.070	0.040	22	MALIEYC07LB422H02□
	2200	25 x 30	2.29	0.13	0.080	0.050	21	MALIEYC07AV422H02□
	3300	25 x 40	3.10	0.13	0.055	0.035	28	MALIEYC07AB433H02□
	3300	30 x 30	2.84	0.16	0.065	0.045	30	MALIEYC07BV433H02□
	4700	25 x 50	3.89	0.14	0.040	0.030	35	MALIEYC07AD447H02□
	4700	30 x 40	3.81	0.16	0.050	0.035	41	MALIEYC07BB447H02□
	6800	30 x 50	4.79	0.19	0.040	< 0.030	51	MALIEYC07BD468H02□
	6800	35 x 40	4.05	0.24	0.050	0.035	56	MALIEYC07CB468H02□
	10 000	35 x 50	5.09	0.27	0.040	< 0.030	70	MALIEYC07CD510H02□

ELECTRICAL DATA AND ORDERING INFORMATION

U_R (V)	C_R 120 Hz (μ F)	NOMINAL CASE SIZE \varnothing D x L (mm)	I_R 120 Hz 105 °C (A)	$\tan \delta$ 120 Hz max.	R_{ESR} 120 Hz max. (Ω)	Z 10 kHz max. (Ω)	WEIGHT (g)	ORDERING CODE
63	680	22 x 25	1.18	0.11	0.215	0.150	13	MALIEYC07LU368J02□
	1000	22 x 30	1.47	0.12	0.160	0.115	16	MALIEYC07LV410J02□
	1500	22 x 40	2.02	0.12	0.110	0.085	22	MALIEYC07LB415J02□
	1500	25 x 30	1.78	0.15	0.135	0.085	21	MALIEYC07AV415J02□
	2200	25 x 40	2.42	0.15	0.095	0.070	28	MALIEYC07AB422J02□
	2200	30 x 30	2.29	0.16	0.100	0.070	30	MALIEYC07BV422J02□
	3300	25 x 50	3.10	0.17	0.070	0.050	35	MALIEYC07AD433J02□
	3300	30 x 40	3.10	0.17	0.070	0.050	41	MALIEYC07BB433J02□
	4700	30 x 50	3.92	0.18	0.055	0.045	51	MALIEYC07BD447J02□
	4700	35 x 40	3.69	0.20	0.060	0.045	56	MALIEYC07CB447J02□
	6800	35 x 50	4.63	0.22	0.045	0.035	70	MALIEYC07CD468J02□
100	330	22 x 25	0.93	0.09	0.365	0.250	13	MALIEYC07LU333L02□
	470	22 x 30	1.15	0.09	0.255	0.190	16	MALIEYC07LV347L02□
	680	22 x 40	1.59	0.09	0.180	0.140	22	MALIEYC07LB368L02□
	680	25 x 30	1.36	0.11	0.215	0.140	21	MALIEYC07AV368L02□
	1000	25 x 40	1.87	0.11	0.150	0.115	28	MALIEYC07AB410L02□
	1000	30 x 30	1.81	0.12	0.160	0.115	30	MALIEYC07BV410L02□
	1500	25 x 50	2.40	0.12	0.110	0.085	35	MALIEYC07AD415L02□
	1500	30 x 40	2.47	0.12	0.110	0.085	41	MALIEYC07BB415L02□
	2200	30 x 50	3.16	0.13	0.080	0.065	51	MALIEYC07BD422L02□
	2200	35 x 40	3.08	0.14	0.085	0.065	56	MALIEYC07CB422L02□
	3300	35 x 50	3.88	0.15	0.065	0.050	70	MALIEYC07CD433L02□
200	330	22 x 30	1.08	0.17	0.68	0.50	16	MALIEYC07LV333S02□
	390	22 x 35	1.23	0.17	0.58	0.47	19	MALIEYC07LA339S02□
	390	25 x 30	1.23	0.17	0.58	0.47	21	MALIEYC07AV339S02□
	470	22 x 40	1.37	0.17	0.48	0.40	22	MALIEYC07LB347S02□
	470	30 x 25	1.27	0.17	0.48	0.40	25	MALIEYC07BU347S02□
	560	25 x 35	1.50	0.17	0.40	0.38	25	MALIEYC07AA356S02□
	560	30 x 30	1.52	0.17	0.40	0.39	30	MALIEYC07BV356S02□
	680	25 x 45	1.82	0.17	0.33	0.34	32	MALIEYC07AC368S02□
	680	30 x 30	1.59	0.17	0.33	0.34	30	MALIEYC07BV368S02□
	680	35 x 25	1.44	0.17	0.33	0.34	35	MALIEYC07CU368S02□
	820	25 x 50	2.04	0.17	0.27	0.24	35	MALIEYC07AD382S02□
	820	30 x 35	1.83	0.17	0.27	0.24	36	MALIEYC07BA382S02□
	820	35 x 30	1.77	0.17	0.27	0.24	42	MALIEYC07CV382S02□
	1000	30 x 45	2.23	0.17	0.23	0.23	46	MALIEYC07BC410S02□
	1000	35 x 35	2.04	0.17	0.23	0.23	49	MALIEYC07CA410S02□
	1200	30 x 50	2.47	0.18	0.20	0.19	51	MALIEYC07BD412S02□
	1200	35 x 35	2.07	0.18	0.20	0.19	49	MALIEYC07CA412S02□
	1500	35 x 45	2.56	0.18	0.16	0.16	63	MALIEYC07CC415S02□
1800	35 x 50	2.80	0.19	0.14	0.13	70	MALIEYC07CD418S02□	



Aluminum Capacitors
Power Printed Wiring Style

Vishay Roederstein

ELECTRICAL DATA AND ORDERING INFORMATION								
U _R (V)	C _R 120 Hz (μF)	NOMINAL CASE SIZE Ø D x L (mm)	I _R 120 Hz 105 °C (A)	tan δ 120 Hz max.	R _{ESR} 120 Hz max. (Ω)	Z 10 kHz max. (Ω)	WEIGHT (g)	ORDERING CODE
250	220	22 x 30	1.00	0.17	1.02	0.70	16	MALIEYC07LV322N02□
	220	25 x 25	1.00	0.17	1.02	0.70	19	MALIEYC07AU322N02□
	270	22 x 35	1.07	0.17	0.84	0.56	19	MALIEYC07LA327N02□
	270	25 x 30	1.08	0.17	0.84	0.56	21	MALIEYC07AV327N02□
	270	30 x 25	1.08	0.17	0.84	0.56	25	MALIEYC07BU327N02□
	330	22 x 40	1.20	0.17	0.68	0.43	22	MALIEYC07LB333N02□
	330	25 x 30	1.21	0.17	0.68	0.43	21	MALIEYC07AV333N02□
	330	30 x 25	1.19	0.17	0.68	0.43	25	MALIEYC07BU333N02□
	390	25 x 35	1.39	0.17	0.58	0.41	25	MALIEYC07AA339N02□
	390	30 x 30	1.41	0.17	0.58	0.41	30	MALIEYC07BV339N02□
	470	25 x 40	1.58	0.17	0.48	0.40	28	MALIEYC07AB347N02□
	470	30 x 30	1.57	0.17	0.48	0.40	30	MALIEYC07BV347N02□
	470	35 x 25	1.37	0.17	0.48	0.40	35	MALIEYC07CU347N02□
	560	25 x 45	1.78	0.17	0.40	0.31	32	MALIEYC07AC356N02□
	560	30 x 35	1.71	0.17	0.40	0.31	36	MALIEYC07BA356N02□
	560	35 x 30	1.67	0.17	0.40	0.31	42	MALIEYC07CV356N02□
	680	30 x 40	1.93	0.17	0.33	0.26	41	MALIEYC07BB368N02□
	680	35 x 35	1.92	0.17	0.33	0.26	49	MALIEYC07CA368N02□
	820	30 x 45	2.16	0.17	0.27	0.21	46	MALIEYC07BC382N02□
	820	35 x 35	1.97	0.17	0.27	0.21	49	MALIEYC07CA382N02□
820	35 x 40	2.16	0.17	0.27	0.21	56	MALIEYC07CB382N02□	
1000	35 x 40	2.22	0.17	0.23	0.18	56	MALIEYC07CB410N02□	
1000	35 x 45	2.41	0.17	0.23	0.18	63	MALIEYC07CC410N02□	
1200	35 x 45	2.46	0.17	0.19	0.16	63	MALIEYC07CC412N02□	
1200	35 x 50	2.65	0.17	0.19	0.16	70	MALIEYC07CD412N02□	
400	68	22 x 25	0.51	0.16	3.12	1.95	13	MALIEYC07LU268X02□
	82	22 x 30	0.60	0.14	2.26	1.52	16	MALIEYC07LV282X02□
	82	25 x 25	0.60	0.14	2.26	1.52	19	MALIEYC07AU282X02□
	100	22 x 35	0.69	0.14	1.86	1.24	19	MALIEYC07LA310X02□
	100	25 x 30	0.70	0.14	1.86	1.24	21	MALIEYC07AV310X02□
	120	22 x 35	0.76	0.14	1.55	1.10	19	MALIEYC07LA312X02□
	120	25 x 30	0.76	0.14	1.55	1.10	21	MALIEYC07AV312X02□
	120	30 x 25	0.77	0.14	1.55	1.10	25	MALIEYC07BU312X02□
	150	22 x 40	0.86	0.15	1.33	0.86	22	MALIEYC07LB315X02□
	150	25 x 35	0.89	0.15	1.33	0.86	25	MALIEYC07AA315X02□
	150	30 x 30	0.92	0.15	1.33	0.86	30	MALIEYC07BV315X02□
	180	25 x 40	1.01	0.15	1.11	0.70	28	MALIEYC07AB318X02□
	180	30 x 30	0.99	0.15	1.11	0.70	30	MALIEYC07BV318X02□
	180	35 x 25	0.96	0.15	1.11	0.70	35	MALIEYC07CU318X02□
	220	25 x 45	1.15	0.15	0.90	0.59	32	MALIEYC07AC322X02□
	220	30 x 35	1.15	0.15	0.90	0.59	36	MALIEYC07BA322X02□
	220	35 x 30	1.14	0.15	0.90	0.59	42	MALIEYC07CV322X02□
	270	25 x 50	1.31	0.15	0.74	0.55	35	MALIEYC07AD327X02□
	270	30 x 40	1.30	0.15	0.74	0.55	41	MALIEYC07BB327X02□

ELECTRICAL DATA AND ORDERING INFORMATION

U_R (V)	C_R 120 Hz (μ F)	NOMINAL CASE SIZE \varnothing D x L (mm)	I_R 120 Hz 105 °C (A)	$\tan \delta$ 120 Hz max.	R_{ESR} 120 Hz max. (Ω)	Z 10 kHz max. (Ω)	WEIGHT (g)	ORDERING CODE
400	270	35 x 30	1.21	0.15	0.74	0.55	42	MALIEYC07CV327X02□
	330	30 x 45	1.47	0.15	0.60	0.45	46	MALIEYC07BC333X02□
	330	35 x 35	1.40	0.15	0.60	0.45	49	MALIEYC07CA333X02□
	390	30 x 50	1.63	0.15	0.51	0.41	51	MALIEYC07BD339X02□
	390	35 x 40	1.57	0.15	0.51	0.41	56	MALIEYC07CB339X02□
	470	35 x 45	1.72	0.15	0.42	0.33	63	MALIEYC07CC347X02□
	560	35 x 50	1.84	0.17	0.40	0.28	70	MALIEYC07CD356X02□
	680	35 x 60	2.24	0.17	0.33	0.23	84	MALIEYC07CF368X02□
450	56	22 x 25	0.48	0.13	3.08	1.88	13	MALIEYC07LU256P02□
	68	22 x 30	0.56	0.12	2.34	1.53	16	MALIEYC07LV268P02□
	68	25 x 25	0.56	0.12	2.34	1.53	19	MALIEYC07AU268P02□
	82	22 x 35	0.64	0.13	2.1	1.29	19	MALIEYC07LA282P02□
	100	22 x 40	0.74	0.13	1.72	1.05	22	MALIEYC07LB310P02□
	100	25 x 30	0.71	0.13	1.72	1.05	21	MALIEYC07AV310P02□
	100	30 x 25	0.73	0.13	1.72	1.05	25	MALIEYC07BU310P02□
	120	25 x 35	0.82	0.13	1.44	0.89	25	MALIEYC07AA312P02□
	150	25 x 40	0.95	0.13	1.15	0.71	28	MALIEYC07AB315P02□
	150	30 x 30	0.93	0.13	1.15	0.71	30	MALIEYC07BV315P02□
	150	35 x 25	0.91	0.13	1.15	0.71	35	MALIEYC07CU315P02□
	180	25 x 45	1.07	0.13	0.96	0.61	32	MALIEYC07AC318P02□
	180	30 x 35	1.06	0.13	0.96	0.61	36	MALIEYC07BA318P02□
	220	30 x 40	1.21	0.12	0.72	0.53	41	MALIEYC07BB322P02□
	220	35 x 30	1.14	0.12	0.72	0.53	42	MALIEYC07CV322P02□
	270	30 x 45	1.37	0.14	0.69	0.45	46	MALIEYC07BC327P02□
	270	35 x 35	1.32	0.14	0.69	0.45	49	MALIEYC07CA327P02□
	330	30 x 50	1.54	0.14	0.56	0.39	51	MALIEYC07BD333P02□
	330	35 x 40	1.49	0.14	0.56	0.39	56	MALIEYC07CB333P02□
	390	35 x 45	1.61	0.14	0.48	0.34	63	MALIEYC07CC339P02□
470	35 x 50	1.72	0.14	0.4	0.29	70	MALIEYC07CD347P02□	
560	35 x 60	2.11	0.15	0.36	0.24	84	MALIEYC07CF356P02□	

ADDITIONAL ELECTRICAL DATA

PARAMETER	CONDITIONS	VALUE
Voltage		
Surge voltage U_s	$U_R \leq 250$ V	$U_s = 1.15 \times U_R$
	$U_R \geq 400$ V	$U_s = 1.10 \times U_R$
Reverse voltage	-	$U_{rev} \leq 1$ V
Current		
Leakage current I_L	$U_R \leq 100$ V; $U_R > 100$ V;	$I_L/\mu A \leq 0.002 \times C_R/\mu F \times U_R/V + 4$ $I_L/\mu A \leq 0.01 \times C_R/\mu F \times U_R/V$
Equivalent series inductance ESL	All case dimensions	25 nH max.

LIFETIME TABLE $U_R \leq 100\text{ V}$

INTERRELATION BETWEEN ALTERNATING CURRENT, AMBIENT TEMPERATURE AND LIFETIME																					
I/I_R (frequency-dependant)								LIFETIME MULTIPLIER L (DEPENDING ON I/I_R AND T_{amb})													
FREQUENCY (Hz)								AMBIENT TEMPERATURE T_{amb} (°C)													
50	100	120	250	500	1000	2500	10 K	40	45	50	55	60	65	70	75	80	85	90	95	100	105
0	0	0	0	0	0	0	0	879	514	291	162	90	51	29	17	10	6.2	3.9	2.6	1.83	1.34
0.18	0.20	0.20	0.21	0.22	0.22	0.23	0.24	833	486	275	153	85	48	27	16	9.5	5.9	3.8	2.6	1.80	1.33
0.36	0.40	0.40	0.42	0.43	0.44	0.45	0.47	763	443	252	141	78	44	25	15	8.9	5.6	3.6	2.4	1.73	1.28
0.55	0.59	0.60	0.62	0.65	0.67	0.68	0.71	680	397	226	126	71	40	23	13	8.2	5.1	3.4	2.3	1.65	1.23
0.73	0.79	0.80	0.83	0.86	0.89	0.90	0.94	588	342	192	107	60	34	20	12	7.2	4.6	3.0	2.1	1.50	1.13
0.91	0.99	1.00	1.04	1.08	1.11	1.13	1.18	470	268	150	84	47	27	16	9.5	5.9	3.8	2.6	1.8	1.31	1.00
1.09	1.19	1.20	1.25	1.30	1.33	1.36	1.42	322	181	101	56	32	19	11	6.8	4.3	2.8	2.0	1.4	1.05	
1.27	1.39	1.40	1.46	1.51	1.55	1.58	1.65	179	95	52	29	17	10	6.5	4.2	2.8	1.9	1.4	1.0		
1.46	1.58	1.60	1.66	1.73	1.78	1.81	1.89	83	47	27	16	10	6.1	3.9	2.6	1.8	1.3				
1.64	1.78	1.80	1.87	1.94	2.00	2.03	2.12	36	21	13	7.8	5.0	3.3	2.2	1.6	1.2					
1.82	1.98	2.00	2.08	2.16	2.22	2.26	2.36	18	11	6.6	4.2	2.8	1.9	1.3	1.0						
2.00	2.18	2.20	2.29	2.38	2.44	2.49	2.60	7.4	4.9	3.2	2.2	1.5	1.0								
2.18	2.38	2.40	2.50	2.59	2.66	2.71	2.83	3.3	2.3	1.6	1.2										
2.37	2.57	2.60	2.70	2.81	2.89	2.94	3.07	1.5	1.2												

**combination
not
permitted**

Notes
 I_R Rated ripple current (120 Hz, RMS) (A) at upper category temperature T_{UC} taken from datasheet

 I User ripple current (A)

 T_{amb} Ambient temperature of capacitor (°C)

 L Lifetime multiplier

 Regard L as a function of ambient temperature (x-axis) and of current (y-axis); use the current-axis according to the frequency

LIFETIME TABLE $U_R > 100\text{ V}$

INTERRELATION BETWEEN ALTERNATING CURRENT, AMBIENT TEMPERATURE AND LIFETIME																					
I/I_R (frequency-dependant)								LIFETIME MULTIPLIER L (DEPENDING ON I/I_R AND T_{amb})													
FREQUENCY (Hz)								AMBIENT TEMPERATURE T_{amb} (°C)													
50	100	120	250	500	1000	2500	10 K	40	45	50	55	60	65	70	75	80	85	90	95	100	105
0	0	0	0	0	0	0	0	879	514	291	162	90	51	29	17	10	6.2	3.9	2.6	1.83	1.34
0.17	0.19	0.20	0.23	0.25	0.26	0.27	0.28	833	486	275	153	85	48	27	16	9.5	5.9	3.8	2.6	1.80	1.33
0.33	0.39	0.40	0.46	0.50	0.52	0.54	0.56	763	443	252	141	78	44	25	15	8.9	5.6	3.6	2.4	1.73	1.28
0.50	0.58	0.60	0.68	0.74	0.78	0.81	0.84	680	397	226	126	71	40	23	13	8.2	5.1	3.4	2.3	1.65	1.23
0.66	0.78	0.80	0.91	0.99	1.04	1.08	1.12	588	342	192	107	60	34	20	12	7.2	4.6	3.0	2.1	1.50	1.13
0.83	0.97	1.00	1.14	1.24	1.30	1.35	1.40	470	268	150	84	47	27	16	9.5	5.9	3.8	2.6	1.8	1.31	1.00
1.00	1.16	1.20	1.37	1.49	1.56	1.62	1.68	322	181	101	56	32	19	11	6.8	4.3	2.8	2.0	1.4	1.05	
1.16	1.36	1.40	1.60	1.74	1.82	1.89	1.96	179	95	52	29	17	10	6.5	4.2	2.8	1.9	1.4	1.0		
1.33	1.55	1.60	1.82	1.98	2.08	2.16	2.24	83	47	27	16	10	6.1	3.9	2.6	1.8	1.3				
1.49	1.75	1.80	2.05	2.23	2.34	2.43	2.52	36	21	13	7.8	5.0	3.3	2.2	1.6	1.2					
1.66	1.94	2.00	2.28	2.48	2.60	2.70	2.80	18	11	6.6	4.2	2.8	1.9	1.3	1.0						
1.83	2.13	2.20	2.51	2.73	2.86	2.97	3.08	7.4	4.9	3.2	2.2	1.5	1.0								
1.99	2.33	2.40	2.74	2.98	3.12	3.24	3.36	3.3	2.3	1.6	1.2										
2.16	2.52	2.60	2.96	3.22	3.38	3.51	3.64	1.5	1.2												

**combination
not
permitted**

Notes
 I_R Rated ripple current (120 Hz, RMS) (A) at upper category temperature T_{UC} taken from datasheet

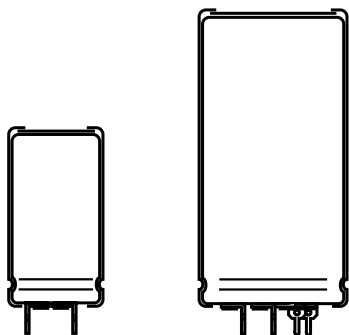
 I User ripple current (A)

 T_{amb} Ambient temperature of capacitor (°C)

 L Lifetime multiplier

 Regard L as a function of ambient temperature (x-axis) and of current (y-axis); use the current-axis according to the frequency

Aluminum Capacitors Power Printed Wiring Style



Component outlines

RoHS
COMPLIANT

FEATURES

- Polarized aluminum electrolytic capacitors, non-solid electrolyte
- Large types with reduced dimensions, cylindrical aluminum case, insulated
- Provided with keyed polarity
- Long useful life: 12 000 h at 85 °C
- High ripple current capability
- High resistance to shock and vibration

APPLICATIONS

- General purpose, industrial and audio/video systems
- Smoothing and filtering
- Standard and switched mode power supplies
- Energy storage in pulse systems

MARKING

The capacitors are marked (where possible) with the following information:

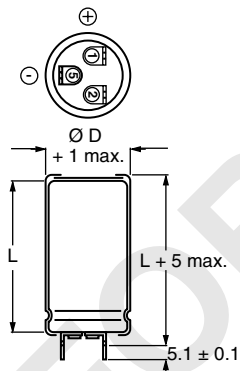
- Rated capacitance (in μF)
- Tolerance on rated capacitance, code letter in accordance with IEC 60062 (M for $\pm 20\%$)
- Rated voltage (in V)
- Date code (YYMM)
- Name of manufacturer
- Code for factory of origin
- Polarity of the terminals and '-' sign to indicate the negative terminal, visible from the top and/or side of the capacitor
- Code number
- Climatic category in accordance with IEC 60068

QUICK REFERENCE DATA		
DESCRIPTION	VALUE	
	$\leq 100\text{ V}$	$> 100\text{ V}$
Nominal case size ($\varnothing D \times L$ in mm)	25 x 30 to 40 x 100	
Rated capacitance range (E6 series), C_R	680 μF to 150 000 μF	68 μF to 2200 μF
Tolerance on C_R	$\pm 20\%$	
Rated voltage range, U_R	10 V to 100 V	200 V to 400 V
Category temperature range	- 40 °C to + 85 °C	
Endurance test at 85 °C	5000 h	
Useful life at 85 °C	12 000 h	
Useful life at 40 °C, $1.4 \times I_R$ applied	190 000 h	
Shelf life at 0 V, 85 °C	500 h	
Based on sectional specification	IEC 60384-4/EN130300	
Climatic category IEC 60068	40/085/56	

SELECTION CHART FOR C_R , U_R AND RELEVANT NOMINAL CASE SIZES ($\varnothing D \times L$ in mm)

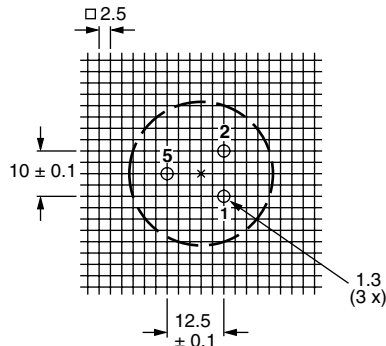
C_R (μF)	U_R (V)								
	10	16	25	40	63	100	200	385	400
68	-	-	-	-	-	-	-	25 x 30	25 x 30
100	-	-	-	-	-	-	-	25 x 40	25 x 40
150	-	-	-	-	-	-	25 x 30	30 x 40	30 x 40
220	-	-	-	-	-	-	25 x 40	35 x 40	35 x 40
330	-	-	-	-	-	-	30 x 40	35 x 50	35 x 50
	-	-	-	-	-	-	-	40 x 40	40 x 40
470	-	-	-	-	-	-	35 x 40	40 x 50	40 x 50
680	-	-	-	-	-	25 x 30	35 x 50	40 x 70	40 x 70
	-	-	-	-	-	-	40 x 40	-	-
1000	-	-	-	-	-	25 x 40	40 x 50	40 x 100	40 x 100
1500	-	-	-	-	-	30 x 40	40 x 70	-	-
2200	-	-	-	-	25 x 30	35 x 40	40 x 100	-	-

SELECTION CHART FOR C_R , U_R AND RELEVANT NOMINAL CASE SIZES ($\varnothing D \times L$ in mm)									
C_R (μF)	U_R (V)								
	10	16	25	40	63	100	200	385	400
3300	-	-	-	25 x 30	25 x 40	35 x 50	-	-	-
	-	-	-	-	-	40 x 40	-	-	-
4700	-	-	25 x 30	25 x 40	30 x 40	40 x 50	-	-	-
6800	-	25 x 30	25 x 40	30 x 40	35 x 40	40 x 70	-	-	-
10 000	25 x 30	25 x 40	30 x 40	35 x 40	35 x 50	40 x 100	-	-	-
	-	-	-	-	40 x 40	-	-	-	-
15 000	25 x 40	30 x 40	35 x 40	35 x 50	40 x 70	-	-	-	-
	-	-	-	40 x 40	-	-	-	-	-
22 000	30 x 40	35 x 40	35 x 50	40 x 50	40 x 100	-	-	-	-
	-	-	40 x 40	-	-	-	-	-	-
33 000	35 x 40	35 x 50	40 x 50	40 x 70	-	-	-	-	-
	-	40 x 40	-	-	-	-	-	-	-
47 000	35 x 50	40 x 50	40 x 70	40 x 100	-	-	-	-	-
	40 x 40	-	-	-	-	-	-	-	-
68 000	40 x 50	40 x 70	40 x 100	-	-	-	-	-	-
100 000	40 x 70	40 x 100	-	-	-	-	-	-	-
150 000	40 x 100	-	-	-	-	-	-	-	-

DIMENSIONS in millimeters **AND AVAILABLE FORMS**


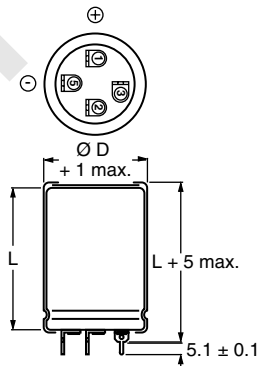
1 = Positive terminal
 5 = Negative terminal
 Case $\varnothing D = 25$ mm

Fig.1 Printed wiring pin version



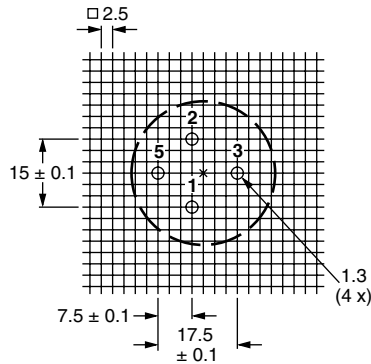
Case $\varnothing D = 25$ mm

Fig.2 Mounting hole pattern viewed from the component side



1 = Positive terminal
 5 = Negative terminal
 Case $\varnothing D = 30$ mm and 35 mm

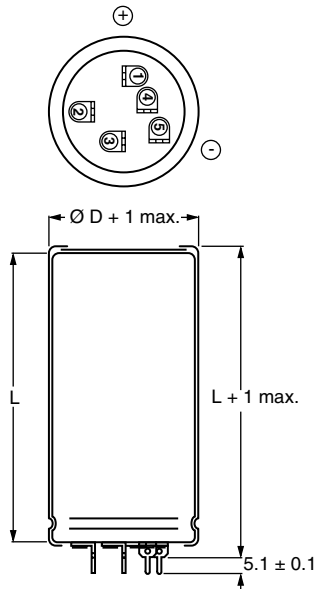
Fig.3 Printed wiring pin version



Case $\varnothing D = 30$ mm and 35 mm

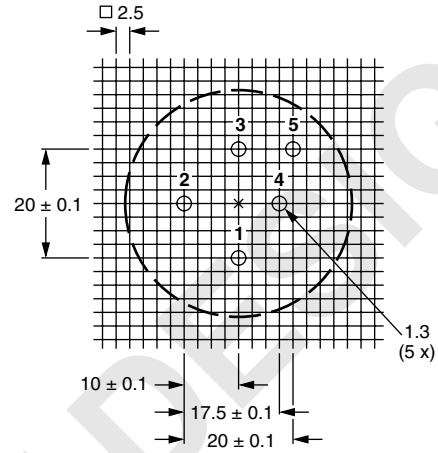
Fig.4 Mounting hole pattern viewed from the component side

DIMENSIONS in millimeters **AND AVAILABLE FORMS** continued



1 = Positive terminal
5 = Negative terminal
Case Ø D = 40 mm

Fig.5 Printed wiring pin version



1 = Positive terminal
5 = Negative terminal
Case Ø D = 40 mm

Fig.6 Mounting hole pattern viewed from the component side

DIMENSIONS in millimeters, MASS AND PACKAGING QUANTITIES					
NOMINAL CASE SIZE Ø D x L	Ø D _{max.}	L _{max.}	MASS (g)	PACKAGING QUANTITIES (units per box)	CARDBOARD BOX DIMENSIONS L x W x H
25 x 30	26	35	≈ 24	100	290 x 280 x 50
25 x 40	26	45	≈ 28	100	290 x 280 x 60
30 x 40	31	45	≈ 38	100	340 x 330 x 60
35 x 40	36	45	≈ 51	50	390 x 198 x 60
35 x 50	36	55	≈ 66	50	390 x 198 x 70
40 x 40	41	45	≈ 78	50	440 x 223 x 60
40 x 50	41	55	≈ 82	50	440 x 223 x 70
40 x 70	41	75	≈ 110	25	230 x 230 x 90
40 x 100	41	105	≈ 176	25	230 x 230 x 120

MOUNTING

When a number of capacitors are connected in a bank, they must not be closer together than 15 mm, when no derating of ripple current and/or temperature is applied.

Pin numbers 2, 3 and 4 (if present) must be free from the electrical circuit.

ELECTRICAL DATA	
SYMBOL	DESCRIPTION
C _R	rated capacitance at 100 Hz
I _R	rated RMS ripple current at 100 Hz, 85 °C or at 20 kHz, 70 °C
I _{L1}	max. leakage current after 1 minute at U _R
I _{L5}	max. leakage current after 5 minutes at U _R
ESR	max. equivalent series resistance at 100 Hz
Z	max. impedance at 10 kHz

Note

- Unless otherwise specified, all electrical values apply at
T_{amb} = 20 °C, P = 86 kPa to 106 kPa, RH = 45 % to 75 %

ORDERING EXAMPLE

10 000 µF/25 V; ± 20 %
Nominal case size: Ø 30 x 40 mm
Ordering code: MALPEYD00BB510E02W

Aluminum Capacitors
Power Printed Wiring Style

Vishay Roederstein

ELECTRICAL DATA AND ORDERING INFORMATION									
U_R (V)	C_R 100 Hz (μ F)	NOMINAL CASE SIZE $\varnothing D \times L$ (mm)	I_R 100 Hz 85 °C (A)	I_R 20 kHz 70 °C (A)	I_{L1} 1 min (mA)	I_{L5} 5 min (mA)	ESR 100 Hz (m Ω)	Z 10 kHz (m Ω)	ORDERING CODE
10	10 000	25 x 30	3.1	5.9	0.60	0.20	51	40	MALPEYD00AV510C02W
	15 000	25 x 40	4.1	7.8	0.90	0.30	37	30	MALPEYD00AB515C02W
	22 000	30 x 40	5.0	9.5	1.32	0.44	30	25	MALPEYD00BB522C02W
	33 000	35 x 40	5.5	10.4	1.98	0.66	28	24	MALPEYD00CB533C02W
	47 000	35 x 50	6.8	12.9	2.82	0.94	23	20	MALPEYD00CD547C02W
	47 000	40 x 40	5.8	10.4	2.82	0.94	29	22	MALPEYD00DB547C02W
	68 000	40 x 50	7.1	13.5	4.08	1.36	24	20	MALPEYD00DD568C02W
	100 000	40 x 70	9.2	17.4	6.00	2.00	19	16	MALPEYD00DG610C02W
	150 000	40 x 100	12.0	22.7	9.00	3.00	16	14	MALPEYD00DM615C02W
16	6800	25 x 30	3.1	5.9	0.65	0.22	53	42	MALPEYD00AV468D02W
	10 000	25 x 40	4.0	7.6	0.96	0.32	39	34	MALPEYD00AB510D02W
	15 000	30 x 40	5.0	9.5	1.44	0.48	31	27	MALPEYD00BB515D02W
	22 000	35 x 40	5.5	10.4	2.12	0.71	29	26	MALPEYD00CB522D02W
	33 000	35 x 50	6.7	12.7	3.17	1.06	23	21	MALPEYD00CD533D02W
	33 000	40 x 40	5.7	10.8	3.17	1.06	30	24	MALPEYD00DB533D02W
	47 000	40 x 50	7.0	13.3	4.52	1.51	24	20	MALPEYD00DD547D02W
	68 000	40 x 70	9.2	17.4	6.53	2.18	19	16	MALPEYD00DG568D02W
	100 000	40 x 100	12.0	22.7	9.60	3.20	16	14	MALPEYD00DM610D02W
25	4700	25 x 30	2.9	5.5	0.71	0.24	60	42	MALPEYD00AV447E02W
	6800	25 x 40	3.9	7.4	1.02	0.34	42	34	MALPEYD00AB468E02W
	10 000	30 x 40	4.8	9.1	1.50	0.50	34	27	MALPEYD00BB510E02W
	15 000	35 x 40	5.3	10.0	2.25	0.75	30	26	MALPEYD00CB515E02W
	22 000	35 x 50	6.5	12.3	3.30	1.10	24	21	MALPEYD00CD522E02W
	22 000	40 x 40	5.7	10.8	3.30	1.10	31	24	MALPEYD00DB522E02W
	33 000	40 x 50	7.0	13.3	4.95	1.65	25	20	MALPEYD00DD533E02W
	47 000	40 x 70	9.2	17.4	7.05	2.35	19	16	MALPEYD00DG547E02W
	68 000	40 x 100	12.0	22.7	10.20	3.40	16	14	MALPEYD00DM568E02W
40	3300	25 x 30	2.9	5.5	0.80	0.27	87	63	MALPEYD00AV433G02W
	4700	25 x 40	3.8	7.2	1.13	0.38	62	47	MALPEYD00AB447G02W
	6800	30 x 40	4.7	8.9	1.64	0.55	49	38	MALPEYD00BB468G02W
	10 000	35 x 40	5.2	9.8	2.40	0.80	48	37	MALPEYD00CB510G02W
	15 000	35 x 50	6.3	11.9	3.60	1.20	37	28	MALPEYD00CD515G02W
	15 000	40 x 40	5.6	10.6	3.60	1.20	50	35	MALPEYD00DB515G02W
	22 000	40 x 50	5.8	11.0	5.28	1.76	39	28	MALPEYD00DD522G02W
	33 000	40 x 70	7.8	14.8	7.92	2.64	28	21	MALPEYD00DG533G02W
	47 000	40 x 100	10.4	19.7	11.28	3.76	22	17	MALPEYD00DM547G02W
63	2200	25 x 30	2.5	4.7	0.84	0.28	83	62	MALPEYD00AV422J02W
	3300	25 x 40	3.3	6.2	1.25	0.42	58	42	MALPEYD00AB433J02W
	4700	30 x 40	4.1	7.8	1.78	0.60	49	38	MALPEYD00BB447J02W
	6800	35 x 40	4.5	8.5	2.57	0.86	48	37	MALPEYD00CB468J02W
	10 000	35 x 50	5.4	10.2	3.78	1.26	37	28	MALPEYD00CD510J02W
	10 000	40 x 40	4.6	8.7	3.78	1.26	52	37	MALPEYD00DB510J02W
	15 000	40 x 70	7.5	14.2	5.67	1.89	29	24	MALPEYD00DG515J02W
	22 000	40 x 100	10.0	19.0	8.32	2.77	22	19	MALPEYD00DM522J02W
100	680	25 x 30	1.74	3.30	0.41	0.14	190	130	MALPEYD00AV368L02W
	1000	25 x 40	2.34	4.44	0.60	0.20	130	90	MALPEYD00AB410L02W
	1500	30 x 40	2.95	5.59	0.90	0.30	95	67	MALPEYD00BB415L02W
	2200	35 x 40	3.69	7.00	1.32	0.44	71	53	MALPEYD00CB422L02W
	3300	35 x 50	4.37	8.29	1.98	0.66	55	41	MALPEYD00CD433L02W
	3300	40 x 40	4.16	7.89	1.98	0.66	64	48	MALPEYD00DB433L02W
	4700	40 x 50	5.21	9.88	2.82	0.94	49	38	MALPEYD00DD447L02W
	6800	40 x 70	6.97	13.22	4.08	1.36	35	28	MALPEYD00DG468L02W
	10 000	40 x 100	9.50	18.00	6.00	2.00	26	21	MALPEYD00DM510L02W

ELECTRICAL DATA AND ORDERING INFORMATION

U_R (V)	C_R 100 Hz (μF)	NOMINAL CASE SIZE $\varnothing D \times L$ (mm)	I_R 100 Hz 85 °C (A)	I_R 20 kHz 70 °C (A)	I_{L1} 1 min (mA)	I_{L5} 5 min (mA)	ESR 100 Hz (m Ω)	Z 10 kHz (m Ω)	ORDERING CODE
200	150	25 x 30	0.70	1.33	0.18	0.06	1000	770	MALPEYD00AV315S02W
	220	25 x 40	0.94	1.78	0.26	0.09	680	525	MALPEYD00AB322S02W
	330	30 x 40	1.27	2.41	0.40	0.14	460	360	MALPEYD00BB333S02W
	470	35 x 40	1.66	3.15	0.57	0.19	320	250	MALPEYD00CB347S02W
	680	35 x 50	2.19	4.15	0.82	0.28	220	170	MALPEYD00CD368S02W
	680	40 x 40	2.17	4.11	0.82	0.28	220	170	MALPEYD00DB368S02W
	1000	40 x 50	2.86	5.42	1.20	0.40	150	115	MALPEYD00DD410S02W
	1500	40 x 70	3.81	7.22	1.80	0.60	110	85	MALPEYD00DG415S02W
	2200	40 x 100	5.20	9.86	2.64	0.88	80	60	MALPEYD00DM422S02W
385	68	25 x 30	0.47	0.89	0.16	0.06	2200	1480	MALPEYD00AV268R02W
	100	25 x 40	0.64	1.21	0.23	0.08	1500	1020	MALPEYD00AB310R02W
	150	30 x 40	0.90	1.71	0.35	0.12	1000	700	MALPEYD00BB315R02W
	220	35 x 40	1.15	2.18	0.51	0.17	680	480	MALPEYD00CB322R02W
	330	35 x 50	1.53	2.90	0.77	0.26	450	340	MALPEYD00CD333R02W
	330	40 x 40	1.52	2.88	0.77	0.26	450	340	MALPEYD00DB333R02W
	470	40 x 50	1.96	3.72	1.09	0.36	320	260	MALPEYD00DD347R02W
	680	40 x 70	2.70	5.12	1.58	0.53	220	190	MALPEYD00DG368R02W
	1000	40 x 100	3.70	7.02	2.31	0.78	180	140	MALPEYD00DM410R02W
400	68	25 x 30	0.54	1.02	0.16	0.06	2100	1000	MALPEYD00AV268X02W
	100	25 x 40	0.73	1.38	0.24	0.08	1400	780	MALPEYD00AB310X02W
	150	30 x 40	0.98	1.86	0.36	0.12	950	520	MALPEYD00BB315X02W
	220	35 x 40	1.28	2.43	0.52	0.17	650	400	MALPEYD00CB322X02W
	330	35 x 50	1.67	3.17	0.79	0.26	480	280	MALPEYD00CD333X02W
	330	40 x 40	1.67	3.17	0.79	0.26	480	280	MALPEYD00DB333X02W
	470	40 x 50	2.12	4.02	1.12	0.37	340	220	MALPEYD00DD347X02W
	680	40 x 70	2.90	5.50	1.63	0.54	235	155	MALPEYD00DG368X02W
	1000	40 x 100	4.05	7.68	2.40	0.80	160	110	MALPEYD00DM410X02W

ADDITIONAL ELECTRICAL DATA

PARAMETER	CONDITIONS	VALUE
Voltage		
Surge voltage	≤ 250 V versions	$U_s = 1.15 \times U_R$
	≥ 385 V versions	$U_s = 1.1 \times U_R$
Reverse voltage		$U_{rev} \leq 1$ V
Current		
Leakage current	After 1 minute at U_R	$I_{L1} \leq 0.006 C_R \times U_R + 4 \mu\text{A}$
	After 5 minutes at U_R	$I_{L5} \leq 0.002 C_R \times U_R + 4 \mu\text{A}$
Inductance		
Equivalent series inductance (ESL)	Case $\varnothing D = 25$ mm	max. 25 nH
	Case $\varnothing D = 30$ mm and 35 mm	max. 30 nH
	Case $\varnothing D = 40$ mm	max. 35 nH



Aluminum Capacitors
Power Printed Wiring Style

Vishay Roederstein

LIFETIME TABLE rated voltage: ≤ 100 V

INTERRELATION BETWEEN ALTERNATING CURRENT, AMBIENT TEMPERATURE AND LIFETIME																	
I/I_R (frequency dependent)						SURFACE TEMPERATURE RISE	LIFETIME MULTIPLIER (depending on I/I_R and T_{amb})										
FREQUENCY (Hz)							AMBIENT TEMPERATURE T_{amb} (°C)										
50	100	250	500	1000	> 2500	ΔT ₀ (°C)	40	45	50	55	60	65	70	75	80	85	
0.19	0.20	0.21	0.22	0.23	0.24	0.2	63	40	26	17	11	7.4	5.0	3.4	2.4	1.64	
0.39	0.40	0.42	0.44	0.46	0.47	0.6	57	36	23	15	10	6.8	4.6	3.2	2.2	1.53	
0.58	0.60	0.62	0.66	0.69	0.71	1.3	48	31	20	13	8.9	6.0	4.1	2.8	2.0	1.38	
0.78	0.80	0.83	0.88	0.92	0.95	2.1	39	25	17	11	7.5	5.1	3.5	2.4	1.7	1.21	
0.97	1.00	1.04	1.10	1.15	1.18	3.2	30	20	13	9.0	6.1	4.2	2.9	2.0	1.4	1.00	
1.17	1.20	1.25	1.31	1.38	1.42	4.4	22	15	10	7.0	4.8	3.4	2.3	1.7	1.2		
1.36	1.40	1.46	1.53	1.61	1.66	6.0	16	11	7.7	5.3	3.7	2.6	1.8	1.3			
1.55	1.60	1.67	1.75	1.84	1.89	7.9	11	8.0	5.6	3.9	2.8	2.0	1.4	1.0			
1.75	1.80	1.87	1.97	2.07	2.13	10	7.8	5.5	3.9	2.8	2.0	1.4	1.0				
1.94	2.00	2.08	2.19	2.30	2.37	12	5.3	3.8	2.7	2.0	1.4	1.0					
2.14	2.20	2.29	2.41	2.53	2.60	15	3.5	2.5	1.8	1.3							
2.33	2.40	2.50	2.63	2.76	2.84	17	2.2	1.6	1.2								
2.53	2.60	2.71	2.85	2.99	3.08	20	1.4	1.1									

Notes

- I_R 100 Hz alternating current (A) at upper category temperature T_{UC} taken from datasheet
- I User current (A)
- T_{amb} Ambient temperature of capacitor (°C)
- ΔT₀ Surface temperature rise of capacitor caused by AC load (°C)
- L Lifetime multiplier

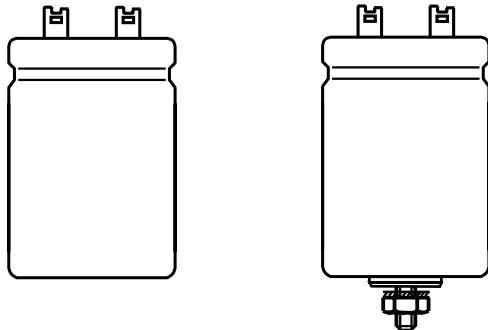
LIFETIME TABLE rated voltage: > 100 V

INTERRELATION BETWEEN ALTERNATING CURRENT, AMBIENT TEMPERATURE AND LIFETIME																	
I/I_R (frequency dependent)						SURFACE TEMPERATURE RISE	LIFETIME MULTIPLIER (depending on I/I_R and T_{amb})										
FREQUENCY (Hz)							AMBIENT TEMPERATURE T_{amb} (°C)										
50	100	250	500	1000	> 2500	ΔT ₀ (°C)	40	45	50	55	60	65	70	75	80	85	
0.16	0.20	0.25	0.27	0.28	0.29	0.2	94	60	38	25	17	11	7.5	5.1	2.4	1.64	
0.32	0.40	0.49	0.54	0.57	0.59	0.6	83	53	35	23	15	10	6.9	3.2	2.2	1.54	
0.48	0.60	0.74	0.81	0.85	0.88	1.2	68	45	30	20	13	9.0	6.2	2.8	2.0	1.39	
0.64	0.80	0.98	1.07	1.13	1.18	2.0	54	36	24	16	11	7.6	5.3	2.5	1.7	1.22	
0.80	1.00	1.23	1.34	1.42	1.47	3.1	41	28	19	13	9.0	6.3	2.9	2.1	1.5	1.00	
0.96	1.20	1.47	1.61	1.70	1.76	4.9	30	21	15	10	7.1	5	2.4	1.7	1.2		
1.12	1.40	1.72	1.88	1.98	2.06	6.7	21	15	11	7.7	5.5	2.6	1.9	1.3			
1.28	1.60	1.96	2.15	2.27	2.35	8.6	15	11	7.9	5.7	2.7	2.0	1.4	1.0			
1.44	1.80	2.21	2.42	2.55	2.65	11	10	7.6	5.6	2.7	2.0	1.5	1.1				
1.60	2.00	2.45	2.69	2.83	2.94	13	7.0	5.3	2.6	2.0	1.5	1.1					
1.76	2.20	2.70	2.95	3.12	3.23	15	3.2	2.4	1.8	1.4	1.0						
1.92	2.40	2.94	3.22	3.40	3.53	18	2.1	1.6	1.2								
2.08	2.60	3.19	3.49	3.68	3.82	20	1.4	1.1									

Notes

- I_R 100 Hz alternating current (A) at upper category temperature T_{UC} taken from datasheet
- I User current (A)
- T_{amb} Ambient temperature of capacitor (°C)
- ΔT₀ Surface temperature rise of capacitor caused by AC load (°C)
- L Lifetime multiplier

Aluminum Capacitors Power Printed Wiring Style



Component outlines

RoHS
COMPLIANT

FEATURES

- Polarized aluminum electrolytic capacitors, non-solid electrolyte
- Large types with reduced dimensions, cylindrical aluminum case, insulated
- Provided with keyed polarity
- Long useful life: 12 000 h at 85 °C
- High ripple current capability
- High resistance to shock and vibration

APPLICATIONS

- General purpose, industrial and audio/video systems
- Smoothing and filtering
- Standard and switched mode power supplies
- Energy storage in pulse systems

MARKING

The capacitors are marked (where possible) with the following information:

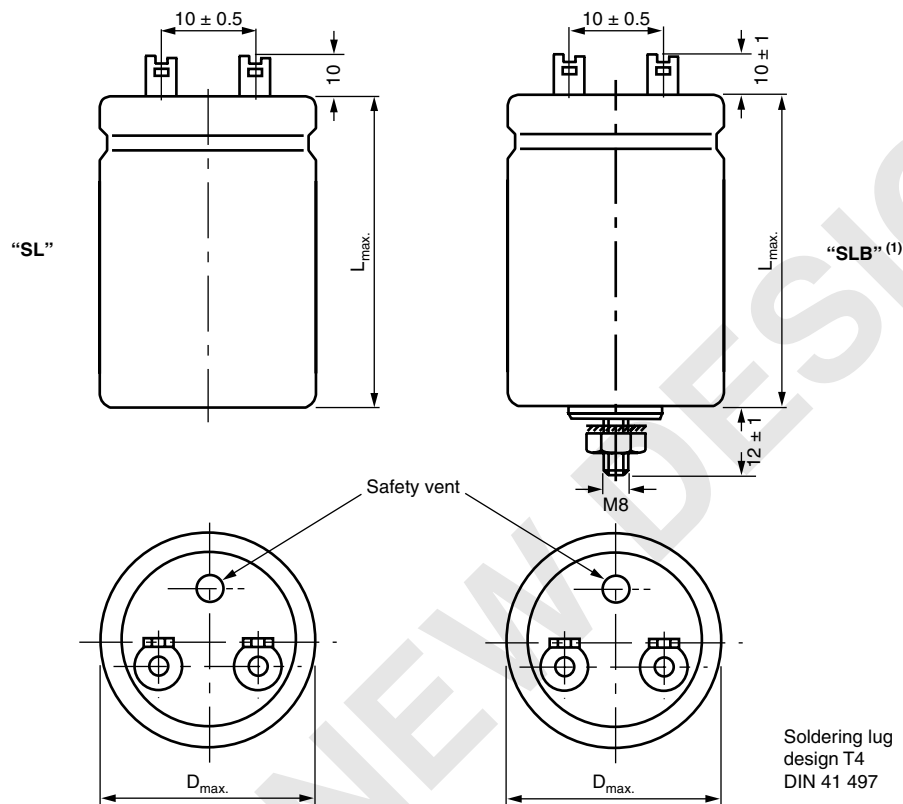
- Rated capacitance (in μF)
- Tolerance on rated capacitance, code letter in accordance with IEC 60062 (M for $\pm 20\%$)
- Rated voltage (in V)
- Date code (YYMM)
- Name of manufacturer
- Code for factory of origin
- Polarity of the terminals and '-' sign to indicate the negative terminal, visible from the top and/or side of the capacitor
- Code number
- Climatic category in accordance with IEC 60068

QUICK REFERENCE DATA

DESCRIPTION	VALUE
	$\leq 100\text{ V}$
Nominal case size ($\varnothing D \times L$ in mm)	25 x 30 to 40 x 100
Rated capacitance range (E6 series), C_R	680 μF to 150 000 μF
Tolerance on C_R	$\pm 20\%$
Rated voltage range, U_R	10 V to 100 V
Category temperature range	- 40 °C to + 85 °C
Endurance test at 85 °C	5000 h
Useful life at 85 °C	12 000 h
Useful life at 40 °C, 1.4 x I_R applied	190 000 h
Shelf life at 0 V, 85 °C	500 h
Based on sectional specification	IEC 60384-4/EN130300
Climatic category IEC 60068	40/085/56

SELECTION CHART FOR C_R , U_R AND RELEVANT NOMINAL CASE SIZES ($\varnothing D \times L$ in mm)

C_R (μF)	U_R (V)					
	10	16	25	40	63	100
680	-	-	-	-	-	25 x 30
1000	-	-	-	-	-	25 x 40
1500	-	-	-	-	-	30 x 40
2200	-	-	-	-	25 x 30	35 x 40
3300	-	-	-	25 x 30	25 x 40	35 x 50
4700	-	-	25 x 30	25 x 40	30 x 40	40 x 50
6800	-	25 x 30	25 x 40	30 x 40	35 x 40	40 x 70
10 000	25 x 30	25 x 40	30 x 40	35 x 40	35 x 50	40 x 100
15 000	25 x 40	30 x 40	35 x 40	35 x 50	40 x 70	-
22 000	30 x 40	35 x 40	35 x 50	40 x 50	40 x 100	-
33 000	35 x 40	35 x 50	40 x 50	40 x 70	-	-
47 000	35 x 50	40 x 50	40 x 70	40 x 100	-	-
68 000	40 x 50	40 x 70	40 x 100	-	-	-
100 000	40 x 70	40 x 100	-	-	-	-
150 000	40 x 100	-	-	-	-	-

DIMENSIONS in millimeters **AND AVAILABLE FORMS**

Note

(1) The MOQ for SLB-version is 5000 pieces

MOUNTING

When a number of capacitors are connected in a bank, they must not be closer together than 15 mm, when no derating of ripple current and/or temperature is applied.

DIMENSIONS in millimeters, MASS AND PACKAGING QUANTITIES					
NOMINAL CASE SIZE Ø D x L	Ø D _{max.}	l _{max.}	MASS (g)	PACKAGING QUANTITIES (units per box)	CARDBOARD BOX DIMENSIONS L x W x H
25 x 30	26	32	≈ 24	100	290 x 280 x 50
25 x 40	26	42	≈ 28	100	290 x 280 x 60
30 x 40	31	42	≈ 38	100	340 x 330 x 60
35 x 40	36	42	≈ 51	50	390 x 198 x 60
35 x 50	36	52	≈ 66	50	390 x 198 x 70
40 x 50	41	52	≈ 82	50	440 x 223 x 70
40 x 70	41	72	≈ 110	25	230 x 230 x 90
40 x 100	41	102	≈ 176	25	230 x 230 x 120



ELECTRICAL DATA	
SYMBOL	DESCRIPTION
C_R	rated capacitance at 100 Hz
I_R	rated RMS ripple current at 100 Hz, 85 °C or at 20 kHz, 70 °C
I_{L1}	max. leakage current after 1 minute at U_R
I_{L5}	max. leakage current after 5 minutes at U_R
ESR	max. equivalent series resistance at 100 Hz
Z	max. impedance at 10 kHz

Note

- Unless otherwise specified, all electrical values apply at $T_{amb} = 20\text{ °C}$, $P = 86\text{ kPa}$ to 106 kPa , $RH = 45\%$ to 75%

ORDERING EXAMPLE

EYK 01: 10 000 $\mu\text{F}/25\text{ V}$

Version 01 (no stud mounting)

Size: 30 mm x 40 mm

Ordering Number: MALLEYK01BB510E02W

EYK 02: 10 000 $\mu\text{F}/25\text{ V}$

Version 02 (stud mounting) ⁽¹⁾

Size: 30 mm x 40 mm

Ordering Number: MALLEYK02BB510E01W

Note

- ⁽¹⁾ MOQ for version 02: 5000 pieces

ELECTRICAL DATA AND ORDERING INFORMATION									
U_R (V)	C_R 100 Hz (μF)	NOMINAL CASE SIZE $\varnothing D \times L$ (mm)	I_R 100 Hz 85 °C (A)	I_R 20 kHz 70 °C (A)	I_{L1} 1 min (mA)	I_{L5} 5 min (mA)	ESR 100 Hz (m Ω)	Z 10 kHz (m Ω)	ORDERING CODE
10	10 000	25 x 30	3.1	5.9	0.60	0.20	51	40	MALLEYK01AV510C02W
	15 000	25 x 40	4.1	7.8	0.90	0.30	37	30	MALLEYK01AB515C02W
	22 000	30 x 40	5.0	9.5	1.32	0.44	30	25	MALLEYK01BB522C02W
	33 000	35 x 40	5.5	10.4	1.98	0.66	28	24	MALLEYK01CB533C02W
	47 000	35 x 50	6.8	12.9	2.82	0.94	23	20	MALLEYK01CD547C02W
	47 000	40 x 40	5.8	10.4	2.82	0.94	29	22	MALLEYK01DB547C02W
	68 000	40 x 50	7.1	13.5	4.08	1.36	24	20	MALLEYK01DD568C02W
	100 000	40 x 70	9.2	17.4	6.00	2.00	19	16	MALLEYK01DG610C02W
	150 000	40 x 100	12.0	22.7	9.00	3.00	16	14	MALLEYK01DM615C02W
16	6800	25 x 30	3.1	5.9	0.65	0.22	53	42	MALLEYK01AV468D02W
	10 000	25 x 40	4.0	7.6	0.96	0.32	39	34	MALLEYK01AB510D02W
	15 000	30 x 40	5.0	9.5	1.44	0.48	31	27	MALLEYK01BB515D02W
	22 000	35 x 40	5.5	10.4	2.12	0.71	29	26	MALLEYK01CB522D02W
	33 000	35 x 50	6.7	12.7	3.17	1.06	23	21	MALLEYK01CD533D02W
	33 000	40 x 40	5.7	10.8	3.17	1.06	30	24	MALLEYK01DB533D02W
	47 000	40 x 50	7.0	13.3	4.52	1.51	24	20	MALLEYK01DD547D02W
	68 000	40 x 70	9.2	17.4	6.53	2.18	19	16	MALLEYK01DG568D02W
	100 000	40 x 100	12.0	22.7	9.60	3.20	16	14	MALLEYK01DM610D02W
25	4700	25 x 30	2.9	5.5	0.71	0.24	60	42	MALLEYK01AV447E02W
	6800	25 x 40	3.9	7.4	1.02	0.34	42	34	MALLEYK01AB468E02W
	10 000	30 x 40	4.8	9.1	1.50	0.50	34	27	MALLEYK01BB510E02W
	15 000	35 x 40	5.3	10.0	2.25	0.75	30	26	MALLEYK01CB515E02W
	22 000	35 x 50	6.5	12.3	3.30	1.10	24	21	MALLEYK01CD522E02W
	22 000	40 x 40	5.7	10.8	3.30	1.10	31	24	MALLEYK01DB522E02W
	33 000	40 x 50	7.0	13.3	4.95	1.65	25	20	MALLEYK01DD533E02W
	47 000	40 x 70	9.2	17.4	7.05	2.35	19	16	MALLEYK01DG547E02W
	68 000	40 x 100	12.0	22.7	10.20	3.40	16	14	MALLEYK01DM568E02W
40	3300	25 x 30	2.9	5.5	0.80	0.27	87	63	MALLEYK01AV433G02W
	4700	25 x 40	3.8	7.2	1.13	0.38	62	47	MALLEYK01AB447G02W
	6800	30 x 40	4.7	8.9	1.64	0.55	49	38	MALLEYK01BB468G02W
	10 000	35 x 40	5.2	9.8	2.40	0.80	48	37	MALLEYK01CB510G02W
	15 000	35 x 50	6.3	11.9	3.60	1.20	37	28	MALLEYK01CD515G02W
	15 000	40 x 40	5.6	10.6	3.60	1.20	50	35	MALLEYK01DB515G02W
	22 000	40 x 50	5.8	11.0	5.28	1.76	39	28	MALLEYK01DD522G02W
	33 000	40 x 70	7.8	14.8	7.92	2.64	28	21	MALLEYK01DG533G02W
	47 000	40 x 100	10.4	19.7	11.28	3.76	22	17	MALLEYK01DM547G02W
63	2200	25 x 30	2.5	4.7	0.84	0.28	83	62	MALLEYK01AV422J02W
	3300	25 x 40	3.3	6.2	1.25	0.42	58	42	MALLEYK01AB433J02W
	4700	30 x 40	4.1	7.8	1.78	0.60	49	38	MALLEYK01BB447J02W
	6800	35 x 40	4.5	8.5	2.57	0.86	48	37	MALLEYK01CB468J02W
	10 000	35 x 50	5.4	10.2	3.78	1.26	37	28	MALLEYK01CD510J02W
	10 000	40 x 40	4.6	8.7	3.78	1.26	52	37	MALLEYK01DB510J02W
	15 000	40 x 70	7.5	14.2	5.67	1.89	29	24	MALLEYK01DG515J02W
22 000	40 x 100	10.0	19.0	8.32	2.77	22	19	MALLEYK01DM522J02W	

ELECTRICAL DATA AND ORDERING INFORMATION									
U_R (V)	C_R 100 Hz (μF)	NOMINAL CASE SIZE $\varnothing D \times L$ (mm)	I_R 100 Hz 85 °C (A)	I_R 20 kHz 70 °C (A)	I_{L1} 1 min (mA)	I_{L5} 5 min (mA)	ESR 100 Hz (m Ω)	Z 10 kHz (m Ω)	ORDERING CODE
100	680	25 x 30	1.74	3.30	0.41	0.14	190	130	MALLEYK01AV368L02W
	1000	25 x 40	2.34	4.44	0.60	0.20	130	90	MALLEYK01AB410L02W
	1500	30 x 40	2.95	5.59	0.90	0.30	95	67	MALLEYK01BB415L02W
	2200	35 x 40	3.69	7.00	1.32	0.44	71	53	MALLEYK01CB422L02W
	3300	35 x 50	4.37	8.29	1.98	0.66	55	41	MALLEYK01CD433L02W
	3300	40 x 40	4.16	7.89	1.98	0.66	64	48	MALLEYK01DB433L02W
	4700	40 x 50	5.21	9.88	2.82	0.94	49	38	MALLEYK01DD447L02W
	6800	40 x 70	6.97	13.22	4.08	1.36	35	28	MALLEYK01DG468L02W
	10 000	40 x 100	9.50	18.00	6.00	2.00	26	21	MALLEYK01DM510L02W

ADDITIONAL ELECTRICAL DATA		
PARAMETER	CONDITIONS	VALUE
Voltage		
Surge voltage	≤ 250 V versions	$U_s = 1.15 \times U_R$
Reverse voltage		$U_{rev} \leq 1$ V
Current		
Leakage current	After 1 minute at U_R	$I_{L1} \leq 0.006 C_R \times U_R + 4 \mu\text{A}$
	After 5 minutes at U_R	$I_{L5} \leq 0.002 C_R \times U_R + 4 \mu\text{A}$
Inductance		
Equivalent series inductance (ESL)	Case $\varnothing D = 25$ mm	max. 25 nH
	Case $\varnothing D = 30$ and 35 mm	max. 30 nH
	Case $\varnothing D = 40$ mm	max. 35 nH

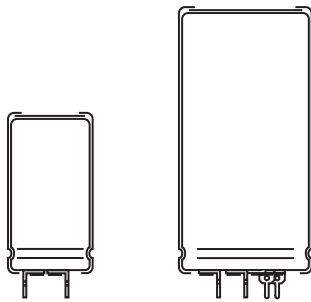
LIFETIME TABLE rated voltage: ≤ 100 V

INTERRELATION BETWEEN ALTERNATING CURRENT, AMBIENT TEMPERATURE AND LIFETIME																
I/I_R (frequency dependent)						SURFACE TEMPERATURE RISE ΔT_0 (°C)	LIFETIME MULTIPLIER (depending on I/I_R and T_{amb})									
FREQUENCY (Hz)							AMBIENT TEMPERATURE T_{amb} (°C)									
50	100	250	500	1000	> 2500		40	45	50	55	60	65	70	75	80	85
0.19	0.20	0.21	0.22	0.23	0.24	0.2	63	40	26	17	11	7.4	5.0	3.4	2.4	1.64
0.39	0.40	0.42	0.44	0.46	0.47	0.6	57	36	23	15	10	6.8	4.6	3.2	2.2	1.53
0.58	0.60	0.62	0.66	0.69	0.71	1.3	48	31	20	13	8.9	6.0	4.1	2.8	2.0	1.38
0.78	0.80	0.83	0.88	0.92	0.95	2.1	39	25	17	11	7.5	5.1	3.5	2.4	1.7	1.21
0.97	1.00	1.04	1.10	1.15	1.18	3.2	30	20	13	9.0	6.1	4.2	2.9	2.0	1.4	1.00
1.17	1.20	1.25	1.31	1.38	1.42	4.4	22	15	10	7.0	4.8	3.4	2.3	1.7	1.2	
1.36	1.40	1.46	1.53	1.61	1.66	6.0	16	11	7.7	5.3	3.7	2.6	1.8	1.3		
1.55	1.60	1.67	1.75	1.84	1.89	7.9	11	8.0	5.6	3.9	2.8	2.0	1.4	1.0		
1.75	1.80	1.87	1.97	2.07	2.13	10	7.8	5.5	3.9	2.8	2.0	1.4	1.0			
1.94	2.00	2.08	2.19	2.30	2.37	12	5.3	3.8	2.7	2.0	1.4	1.0				
2.14	2.20	2.29	2.41	2.53	2.60	15	3.5	2.5	1.8	1.3						
2.33	2.40	2.50	2.63	2.76	2.84	17	2.2	1.6	1.2							
2.53	2.60	2.71	2.85	2.99	3.08	20	1.4	1.1								

Notes

- I_R 100 Hz alternating current (A) at upper category temperature T_{UC} taken from datasheet
- I User current (A)
- T_{amb} Ambient temperature of capacitor (°C)
- ΔT_0 Surface temperature rise of capacitor caused by AC load (°C)
- L Lifetime multiplier

Aluminum Capacitors Power Printed Wiring Style



Component outlines

RoHS
COMPLIANT

FEATURES

- Polarized aluminum electrolytic capacitors, non-solid electrolyte
- Large types, cylindrical aluminum case, insulated
- Provided with keyed polarity
- Very long useful life: 15 000 h at 85 °C
- Low ESR, high ripple current capability
- High resistance to shock and vibration

APPLICATIONS

- Computer, telecommunication and industrial systems
- Smoothing and filtering
- Standard and switched mode power supplies
- Energy storage in pulse systems

MARKING

The capacitors are marked (where possible) with the following information:

- Rated capacitance (in μF)
- Tolerance on rated capacitance, code letter in accordance with IEC 60062 (Q for - 10 %/+ 30 %)
- Rated voltage (in V)
- Date code (YYMM)
- Name of manufacturer
- Code for factory of origin
- Polarity of the terminals and '-' sign to indicate the negative terminal, visible from the top and/or side of the capacitor
- Code number
- Climatic category in accordance with IEC 60068

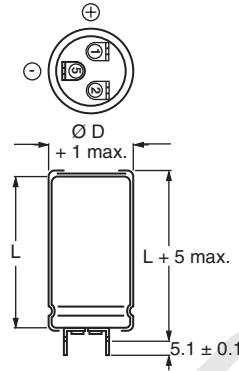
QUICK REFERENCE DATA

DESCRIPTION	VALUE	
	$\leq 100 \text{ V}$	$> 100 \text{ V}$
Nominal case size ($\varnothing D \times L$ in mm)	25 x 30 to 40 x 100	
Rated capacitance range (E6 series), C_R	470 μF to 68 000 μF	47 μF to 1000 μF
Tolerance on C_R	- 10 % to + 30 %	
Rated voltage range, U_R	10 V to 100 V	250 V to 400 V
Category temperature range	- 40 °C to + 85 °C	
Endurance test at 85 °C	5000 h	
Useful life at 85 °C	15 000 h	
Useful life at 40 °C, 1.4 x I_R applied	200 000 h	
Shelf life at 0 V, 85 °C	500 h	
Based on sectional specification	IEC 60384-4/EN130300	
Climatic category IEC 60068	40/085/56	

SELECTION CHART FOR C_R , U_R AND RELEVANT NOMINAL CASE SIZES ($\varnothing D \times L$ in mm)

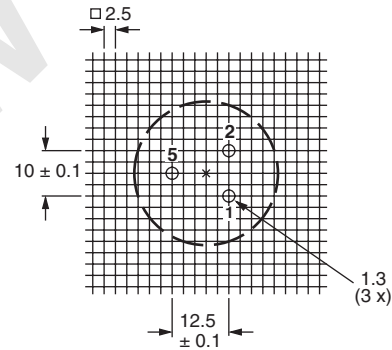
C_R (μF)	U_R (V)					
	10	16	25	40	63	100
470	-	-	-	-	-	25 x 30
680	-	-	-	-	-	25 x 40
1000	-	-	-	-	25 x 30	30 x 40
1500	-	-	-	25 x 30	25 x 40	35 x 40
2200	-	-	25 x 30	25 x 40	30 x 40	35 x 50
	-	-	-	-	-	40 x 40
3300	-	25 x 30	25 x 40	30 x 40	35 x 40	40 x 50
4700	25 x 30	25 x 40	30 x 40	35 x 40	35 x 50	40 x 70
	-	-	-	-	40 x 40	-
6800	25 x 40	30 x 40	35 x 40	35 x 50	40 x 50	40 x 100
	-	-	-	40 x 40	-	-
10 000	30 x 40	35 x 40	35 x 50	40 x 50	40 x 70	-
	-	-	40 x 40	-	-	-
15 000	35 x 40	35 x 50	40 x 50	40 x 70	40 x 100	-
	-	40 x 40	-	-	-	-
22 000	35 x 50	40 x 50	40 x 70	40 x 100	-	-
	40 x 40	-	-	-	-	-
33 000	40 x 50	40 x 70	40 x 100	-	-	-
47 000	40 x 70	40 x 100	-	-	-	-
68 000	40 x 100	-	-	-	-	-

SELECTION CHART FOR C_R, U_R AND RELEVANT NOMINAL CASE SIZES ($\varnothing D \times L$ in mm)			
C_R (μF)	U_R (V)		
	250	385	400
47	-	25 x 30	25 x 30
68	-	25 x 40	25 x 40
100	25 x 30	30 x 40	30 x 40
150	25 x 40	35 x 40	35 x 40
220	30 x 40	35 x 50	35 x 50
	-	40 x 40	40 x 40
330	35 x 40	40 x 50	40 x 50
470	35 x 50	40 x 70	40 x 70
	40 x 40	-	-
680	40 x 50	-	40 x 100
1000	40 x 70	-	-

DIMENSIONS in millimeters AND AVAILABLE FORMS


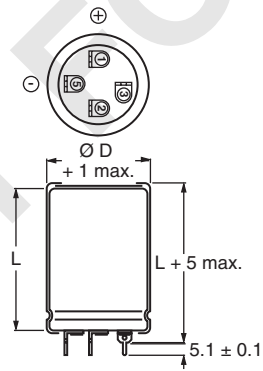
1 = Positive terminal
 5 = Negative terminal
 Case $\varnothing D = 25$ mm

Fig.1 Printed wiring pin version



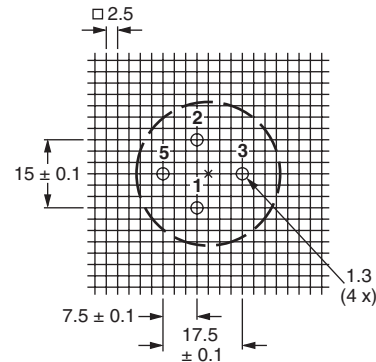
Case $\varnothing D = 25$ mm

Fig.2 Mounting hole pattern viewed from the component side



1 = Positive terminal
 5 = Negative terminal
 Case $\varnothing D = 30$ mm and 35 mm

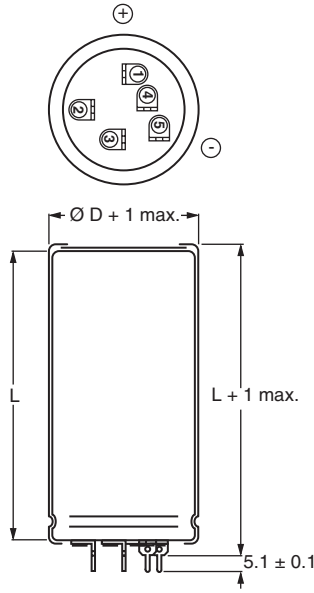
Fig.3 Printed wiring pin version



Case $\varnothing D = 30$ mm and 35 mm

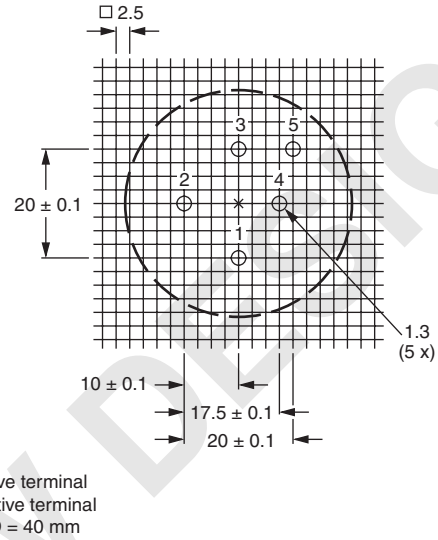
Fig.4 Mounting hole pattern viewed from the component side

DIMENSIONS in millimeters **AND AVAILABLE FORMS**



1 = Positive terminal
5 = Negative terminal
Case Ø D = 40 mm

Fig.5 Printed wiring pin version



1 = Positive terminal
5 = Negative terminal
Case Ø D = 40 mm

Fig.6 Mounting hole pattern viewed from the component side

DIMENSIONS in millimeters, MASS AND PACKAGING QUANTITIES					
NOMINAL CASE SIZE Ø D x L	Ø D _{max.}	L _{max.}	MASS (g)	PACKAGING QUANTITIES (units per box)	CARDBOARD BOX DIMENSIONS L x W x H
25 x 30	26	35	≈ 24	100	290 x 280 x 50
25 x 40	26	45	≈ 28	100	290 x 280 x 60
30 x 40	31	45	≈ 38	100	340 x 330 x 60
35 x 40	36	45	≈ 51	50	390 x 198 x 60
35 x 50	36	55	≈ 66	50	390 x 198 x 70
40 x 40	41	45	≈ 78	50	440 x 223 x 60
40 x 50	41	55	≈ 82	50	440 x 223 x 70
40 x 70	41	75	≈ 110	25	230 x 230 x 90
40 x 100	41	105	≈ 176	25	230 x 230 x 120

MOUNTING

When a number of capacitors are connected in a bank, they must not be closer together than 15 mm, when no derating of ripple current and/or temperature is applied.

Pin numbers 2, 3 and 4 (if present) must be free from the electrical circuit.



Aluminum Capacitors
Power Printed Wiring Style

Vishay Roederstein

ELECTRICAL DATA	
SYMBOL	DESCRIPTION
C _R	rated capacitance at 100 Hz
I _R	rated RMS ripple current at 100 Hz, 85 °C or at 20 kHz, 70 °C
I _{L1}	max. leakage current after 1 minute at U _R
I _{L5}	max. leakage current after 5 minutes at U _R
ESR	max. equivalent series resistance at 100 Hz
Z	max. impedance at 10 kHz

ORDERING EXAMPLE

10 000 µF/25 V; - 10 %/+ 30 %

Nominal case size: Ø 35 x 50 mm

Ordering code: MALPEYV00CD510E02W

Note

- Unless otherwise specified, all electrical values apply at T_{amb} = 20 °C, P = 86 kPa to 106 kPa, RH = 45 % to 75 %

ELECTRICAL DATA AND ORDERING INFORMATION									
U _R (V)	C _R 100 Hz (µF)	NOMINAL CASE SIZE Ø D x L (mm)	I _R 100 Hz 85 °C (A)	I _R 20 kHz 70 °C (A)	I _{L1} 1 min (mA)	I _{L5} 5 min (mA)	ESR 100 Hz (mΩ)	Z 10 kHz (mΩ)	ORDERING CODE
10	4700	25 x 30	2.4	4.6	0.28	0.10	74	50	MALPEYV00AV447C02W
	6800	25 x 40	3.2	6.1	0.41	0.14	51	37	MALPEYV00AB468C02W
	10 000	30 x 40	3.8	7.2	0.60	0.20	39	29	MALPEYV00BB510C02W
	15 000	35 x 40	4.1	7.8	0.90	0.30	35	26	MALPEYV00CB515C02W
	22 000	35 x 50	5.0	9.5	1.32	0.44	27	21	MALPEYV00CD522C02W
	22 000	40 x 40	4.2	8.0	1.32	0.44	36	27	MALPEYV00DB522C02W
	33 000	40 x 50	5.0	9.5	1.98	0.66	29	22	MALPEYV00DD533C02W
	47 000	40 x 70	6.8	12.9	2.82	0.94	20	17	MALPEYV00DG547C02W
	68 000	40 x 100	9.2	17.5	4.08	1.36	15	14	MALPEYV00DM568C02W
16	3300	25 x 30	2.4	4.6	0.32	0.11	75	50	MALPEYV00AV433D02W
	4700	25 x 40	3.1	5.9	0.45	0.15	52	37	MALPEYV00AB447D02W
	6800	30 x 40	3.7	7.0	0.65	0.22	40	30	MALPEYV00BB468D02W
	10 000	35 x 40	4.1	7.8	0.96	0.32	36	27	MALPEYV00CB510D02W
	15 000	35 x 50	5.0	9.5	1.44	0.48	28	21	MALPEYV00CD515D02W
	15 000	40 x 40	4.2	8.0	1.44	0.48	36	27	MALPEYV00DB515D02W
	22 000	40 x 50	5.0	9.5	2.12	0.71	29	22	MALPEYV00DD522D02W
	33 000	40 x 70	6.7	12.7	3.17	1.06	20	17	MALPEYV00DG533D02W
	47 000	40 x 100	9.1	17.3	4.51	1.51	15	14	MALPEYV00DM547D02W
25	2200	25 x 30	2.3	4.4	0.33	0.11	78	52	MALPEYV00AV422E02W
	3300	25 x 40	3.1	5.9	0.49	0.17	53	38	MALPEYV00AB433E02W
	4700	30 x 40	3.7	7.0	0.70	0.24	42	31	MALPEYV00BB447E02W
	6800	35 x 40	4.1	7.8	1.02	0.34	37	28	MALPEYV00CB468E02W
	10 000	35 x 50	5.0	9.5	1.50	0.50	28	21	MALPEYV00CD510E02W
	10 000	40 x 40	4.2	8.0	1.50	0.50	36	27	MALPEYV00DB510E02W
	15 000	40 x 50	5.0	9.5	2.25	0.75	29	22	MALPEYV00DD515E02W
	22 000	40 x 70	6.8	12.9	3.30	1.10	20	17	MALPEYV00DG522E02W
	33 000	40 x 100	9.2	17.5	4.95	1.65	15	14	MALPEYV00DM533E02W
40	1500	25 x 30	2.0	3.8	0.36	0.12	112	68	MALPEYV00AV415G02W
	2200	25 x 40	2.7	5.1	0.53	0.18	76	51	MALPEYV00AB422G02W
	3300	30 x 40	3.3	6.3	0.79	0.27	57	41	MALPEYV00BB433G02W
	4700	35 x 40	3.8	7.2	1.13	0.38	48	35	MALPEYV00CB447G02W
	6800	35 x 50	4.7	8.9	1.64	0.55	36	27	MALPEYV00CD468G02W
	6800	40 x 40	4.1	7.8	1.64	0.55	45	33	MALPEYV00DB468G02W
	10 000	40 x 50	4.9	9.3	2.40	0.80	35	27	MALPEYV00DD510G02W
	15 000	40 x 70	6.6	12.5	3.60	1.20	25	20	MALPEYV00DG515G02W
	22 000	40 x 100	9.0	17.1	5.28	1.76	18	16	MALPEYV00DM522G02W
63	1000	25 x 30	1.8	3.4	0.38	0.13	122	74	MALPEYV00AV410J02W
	1500	25 x 40	2.5	4.7	0.57	0.19	83	54	MALPEYV00AB415J02W
	2200	30 x 40	3.1	5.9	0.83	0.28	57	41	MALPEYV00BB422J02W
	3300	35 x 40	3.6	6.8	1.25	0.42	48	35	MALPEYV00CB433J02W
	4700	35 x 50	4.4	8.3	1.78	0.60	36	27	MALPEYV00CD447J02W
	4700	40 x 40	3.8	7.2	1.78	0.60	45	33	MALPEYV00DB447J02W
	6800	40 x 50	4.7	8.9	2.57	0.86	35	27	MALPEYV00DD468J02W
	10 000	40 x 70	6.2	11.8	3.78	1.26	25	20	MALPEYV00DG510J02W
	15 000	40 x 100	8.5	16.1	5.67	1.89	18	16	MALPEYV00DM515J02W

ELECTRICAL DATA AND ORDERING INFORMATION

U_R (V)	C_R 100 Hz (μ F)	NOMINAL CASE SIZE \varnothing D x L (mm)	I_R 100 Hz 85 °C (A)	I_R 20 kHz 70 °C (A)	I_{L1} 1 min (mA)	I_{L5} 5 min (mA)	ESR 100 Hz (m Ω)	Z 10 kHz (m Ω)	ORDERING CODE
100	470	25 x 30	1.4	2.7	0.28	0.10	247	172	MALPEYV00AV347L02W
	680	25 x 40	1.9	3.6	0.41	0.14	170	116	MALPEYV00AB368L02W
	1000	30 x 40	2.5	4.7	0.60	0.20	123	88	MALPEYV00BB410L02W
	1500	35 x 40	3.1	5.8	0.90	0.30	94	71	MALPEYV00CB415L02W
	2200	35 x 50	3.9	7.4	1.32	0.44	69	55	MALPEYV00CD422L02W
	2200	40 x 40	3.6	6.8	1.32	0.44	81	65	MALPEYV00DB422L02W
	3300	40 x 50	4.6	8.7	1.98	0.66	59	48	MALPEYV00DD433L02W
	4700	40 x 70	6.2	11.7	2.82	0.94	42	36	MALPEYV00DG447L02W
	6800	40 x 100	8.2	15.5	4.08	1.36	32	28	MALPEYV00DM468L02W
250	100	25 x 30	0.6	1.15	0.15	0.05	1800	1300	MALPEYV00AV310N02W
	150	25 x 40	0.8	1.5	0.23	0.08	1100	850	MALPEYV00AB315N02W
	220	30 x 40	1.0	1.9	0.33	0.11	750	550	MALPEYV00BB322N02W
	330	35 x 40	1.4	2.65	0.49	0.17	500	400	MALPEYV00CB333N02W
	470	35 x 50	1.8	3.4	0.70	0.24	360	290	MALPEYV00CD347N02W
	470	40 x 40	1.8	3.4	0.70	0.24	420	350	MALPEYV00DB347N02W
	680	40 x 50	2.3	4.4	1.02	0.34	250	190	MALPEYV00DD368N02W
	1000	40 x 70	3.0	5.7	1.50	0.50	170	140	MALPEYV00DG410N02W
385	47	25 x 30	0.5	0.94	0.11	0.04	2370	1550	MALPEYV00AV247R02W
	68	25 x 40	0.67	1.27	0.16	0.06	1640	1100	MALPEYV00AB268R02W
	100	30 x 40	0.84	1.59	0.23	0.08	1275	950	MALPEYV00BB310R02W
	150	35 x 40	1.13	2.14	0.34	0.11	850	635	MALPEYV00CB315R02W
	220	35 x 50	1.48	2.8	0.50	0.17	580	430	MALPEYV00CD322R02W
	220	40 x 40	1.48	2.8	0.50	0.17	580	430	MALPEYV00DB322R02W
	330	40 x 50	1.97	3.73	0.75	0.25	385	300	MALPEYV00DD333R02W
	470	40 x 70	2.7	5.11	1.06	0.36	270	215	MALPEYV00DG347R02W
400	47	25 x 30	0.47	0.89	0.11	0.04	2700	2125	MALPEYV00AV247X02W
	68	25 x 40	0.63	1.29	0.16	0.06	1875	1470	MALPEYV00AB268X02W
	100	30 x 40	0.84	1.59	0.24	0.08	1275	1000	MALPEYV00BB310X02W
	150	35 x 40	1.13	2.14	0.36	0.12	850	665	MALPEYV00CB315X02W
	220	35 x 50	1.41	2.67	0.52	0.17	650	450	MALPEYV00CD322X02W
	220	40 x 40	1.41	2.67	0.52	0.17	650	450	MALPEYV00DB322X02W
	330	40 x 50	1.86	3.52	0.79	0.26	435	315	MALPEYV00DD333X02W
	470	40 x 70	2.54	4.81	1.12	0.37	305	225	MALPEYV00DG347X02W
	680	40 x 100	3.56	6.75	1.63	0.54	210	155	MALPEYV00DM368X02W

Note

- 450 V on request

ADDITIONAL ELECTRICAL DATA

PARAMETER	CONDITIONS	VALUE
Voltage		
Surge voltage	≤ 250 V versions	$U_s = 1.15 \times U_R$
	≥ 385 V versions	$U_s = 1.1 \times U_R$
Reverse voltage		$U_{rev} \leq 1$ V
Current		
Leakage current	After 1 minute at U_R	$I_{L1} \leq 0.006 C_R \times U_R + 4 \mu$ A
	After 5 minutes at U_R	$I_{L5} \leq 0.002 C_R \times U_R + 4 \mu$ A
Inductance		
Equivalent series inductance (ESL)	Case \varnothing D = 25 mm	max. 25 nH
	Case \varnothing D = 30 and 35 mm	max. 30 nH
	Case \varnothing D = 40 mm	max. 35 nH



Aluminum Capacitors
Power Printed Wiring Style

Vishay Roederstein

LIFETIME TABLE rated voltage: ≤ 100 V

INTERRELATION BETWEEN ALTERNATING CURRENT, AMBIENT TEMPERATURE AND LIFETIME																
I/I_R (frequency dependent)						SURFACE TEMPERATURE RISE ΔT_0 (°C)	LIFETIME MULTIPLIER (depending on I/I_R and T_{amb})									
FREQUENCY (Hz)							AMBIENT TEMPERATURE T_{amb} (°C)									
50	100	250	500	1000	> 2500		40	45	50	55	60	65	70	75	80	85
0.19	0.20	0.21	0.22	0.22	0.23	0.2	63	40	26	17	11	7.3	5.0	3.4	2.3	1.63
0.38	0.40	0.42	0.43	0.45	0.47	0.7	55	35	23	15	9.9	6.7	4.5	3.1	2.2	1.51
0.56	0.60	0.63	0.65	0.67	0.70	1.5	45	29	19	13	8.5	5.7	3.9	2.7	1.9	1.33
0.75	0.80	0.84	0.86	0.89	0.94	2.5	35	23	15	10	6.9	4.7	3.3	2.3	1.6	1.13
0.94	1.00	1.05	1.08	1.12	1.17	3.8	26	17	12	7.9	5.4	3.7	2.6	1.8	1.3	1.00
1.13	1.20	1.26	1.29	1.34	1.41	5.4	18	13	8.6	5.9	4.1	2.9	2.0	1.4	1.0	
1.31	1.40	1.47	1.51	1.56	1.64	7.4	13	8.7	6.1	4.2	3.0	2.1	1.5	1.1		
1.50	1.60	1.68	1.72	1.79	1.87	9.6	8.3	5.9	4.2	3.0	2.1	1.5	1.1			
1.69	1.80	1.89	1.94	2.01	2.11	12	5.4	3.9	2.8	2.0	1.4	1.0				
1.88	2.00	2.10	2.15	2.23	2.34	15	3.4	2.5	1.8	1.3						
2.06	2.20	2.30	2.37	2.45	2.58	18	2.1	1.5	1.1							
2.25	2.40	2.51	2.58	2.68	2.81	21	1.2									

Notes

- I_R 100 Hz alternating current (A) at upper category temperature T_{UC} taken from datasheet
- I User current (A)
- T_{amb} Ambient temperature of capacitor (°C)
- ΔT_0 Surface temperature rise of capacitor caused by AC load (°C)
- L Lifetime multiplier

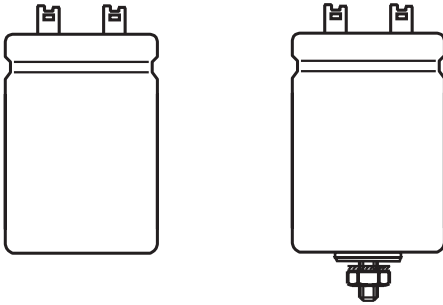
LIFETIME TABLE rated voltage: > 100 V

INTERRELATION BETWEEN ALTERNATING CURRENT, AMBIENT TEMPERATURE AND LIFETIME																
I/I_R (frequency dependent)						SURFACE TEMPERATURE RISE ΔT_0 (°C)	LIFETIME MULTIPLIER (depending on I/I_R and T_{amb})									
FREQUENCY (Hz)							AMBIENT TEMPERATURE T_{amb} (°C)									
50	100	250	500	1000	> 2500		40	45	50	55	60	65	70	75	80	85
0.16	0.20	0.26	0.29	0.31	0.33	0.2	78	50	32	21	14	9.2	6.2	4.2	2.3	1.64
0.31	0.40	0.51	0.58	0.63	0.66	0.6	68	44	29	19	12	8.4	5.7	3.1	2.2	1.53
0.47	0.60	0.77	0.87	0.94	0.99	1.3	56	37	24	16	11	7.3	5.0	2.8	1.9	1.36
0.62	0.80	1.03	1.16	1.25	1.32	2.3	43	29	19	13	8.9	6.1	4.2	2.4	1.7	1.18
0.78	1.00	1.29	1.45	1.57	1.65	3.4	32	22	15	10	7.1	4.9	2.8	2.0	1.4	1.00
0.93	1.20	1.54	1.74	1.88	1.98	5.3	23	16	11	7.8	5.5	3.1	2.2	1.6	1.1	
1.09	1.40	1.80	2.04	2.19	2.31	7.2	16	12	8.2	5.8	4.1	2.4	1.7	1.2		
1.24	1.60	2.06	2.33	2.51	2.64	9.3	11	8.0	5.8	4.2	2.4	1.7	1.3			
1.40	1.80	2.31	2.62	2.82	2.97	12	7.4	5.4	3.2	2.3	1.7	1.3				
1.56	2.00	2.57	2.91	3.13	3.30	14	4.9	2.9	2.2	1.6	1.2					
1.71	2.20	2.83	3.20	3.45	3.63	17	2.5	1.9	1.5	1.1						
1.86	2.40	3.09	3.49	3.76	3.96	19	1.6	1.2								
2.02	2.60	3.34	3.78	4.07	4.29	22	1.0									

Notes

- I_R 100 Hz alternating current (A) at upper category temperature T_{UC} taken from datasheet
- I User current (A)
- T_{amb} Ambient temperature of capacitor (°C)
- ΔT_0 Surface temperature rise of capacitor caused by AC load (°C)
- L Lifetime multiplier

Aluminum Capacitors Power Printed Wiring Style



Component outlines

RoHS
COMPLIANT

FEATURES

- Polarized aluminum electrolytic capacitors, non-solid electrolyte
- Large types, cylindrical aluminum case, insulated
- Provided with keyed polarity
- Very long useful life: 15 000 h at 85 °C
- Low ESR, high ripple current capability
- High resistance to shock and vibration

APPLICATIONS

- Computer, telecommunication and industrial systems
- Smoothing and filtering
- Standard and switched mode power supplies
- Energy storage in pulse systems

MARKING

The capacitors are marked (where possible) with the following information:

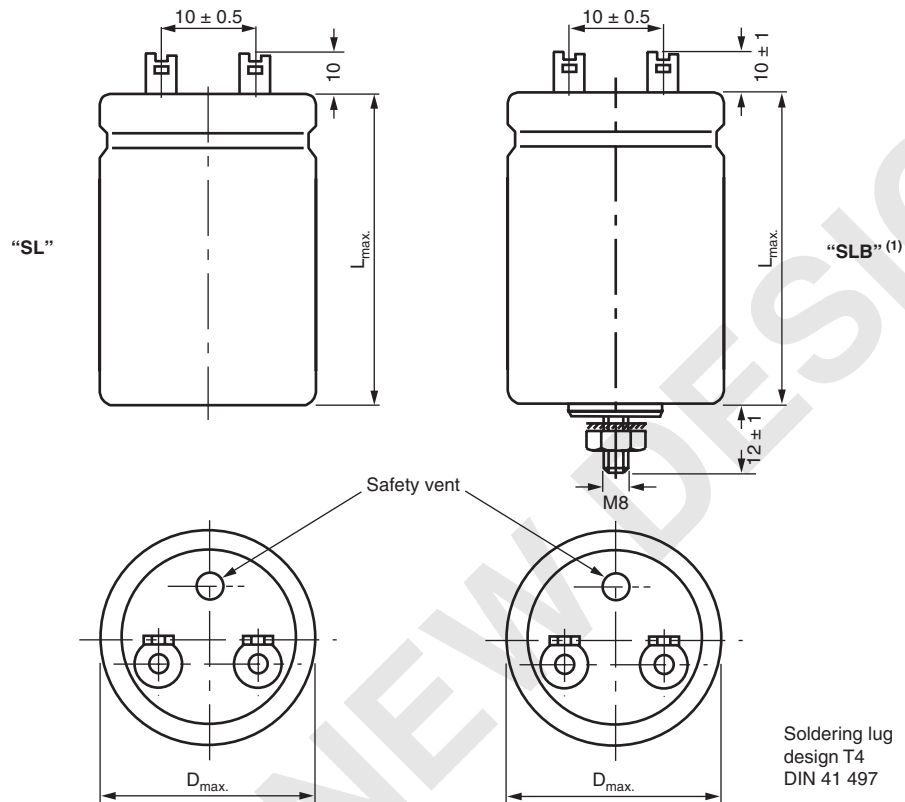
- Rated capacitance (in μF)
- Tolerance on rated capacitance, code letter in accordance with IEC 60062 (Q for - 10 %/+ 30 %)
- Rated voltage (in V)
- Date code (YYMM)
- Name of manufacturer
- Code for factory of origin
- Polarity of the terminals and '-' sign to indicate the negative terminal, visible from the top and/or side of the capacitor
- Code number
- Climatic category in accordance with IEC 60068

QUICK REFERENCE DATA

DESCRIPTION	VALUE
	$\leq 100 \text{ V}$
Nominal case size ($\varnothing D \times L$ in mm)	25 x 30 to 40 x 100
Rated capacitance range (E6 series), C_R	470 μF to 68 000 μF
Tolerance on C_R	- 10 % to + 30 %
Rated voltage range, U_R	10 V to 100 V
Category temperature range	- 40 °C to + 85 °C
Endurance test at 85 °C	5000 h
Useful life at 85 °C	15 000 h
Useful life at 40 °C, 1.4 x I_R applied	200 000 h
Shelf life at 0 V, 85 °C	500 h
Based on sectional specification	IEC 60384-4/EN130300
Climatic category IEC 60068	40/085/56

SELECTION CHART FOR C_R , U_R AND RELEVANT NOMINAL CASE SIZES ($\varnothing D \times L$ in mm)

C_R (μF)	U_R (V)					
	10	16	25	40	63	100
470	-	-	-	-	-	25 x 30
680	-	-	-	-	-	25 x 40
1000	-	-	-	-	25 x 30	30 x 40
1500	-	-	-	25 x 30	25 x 40	35 x 40
2200	-	-	25 x 30	25 x 40	30 x 40	35 x 50
3300	-	25 x 30	25 x 40	30 x 40	35 x 40	40 x 50
4700	25 x 30	25 x 40	30 x 40	35 x 40	35 x 50	40 x 70
6800	25 x 40	30 x 40	35 x 40	35 x 50	40 x 50	40 x 100
10 000	30 x 40	35 x 40	35 x 50	40 x 50	40 x 70	-
15 000	35 x 40	35 x 50	40 x 50	40 x 70	40 x 100	-
22 000	35 x 50	40 x 50	40 x 70	40 x 100	-	-
33 000	40 x 50	40 x 70	40 x 100	-	-	-
47 000	40 x 70	40 x 100	-	-	-	-
68 000	40 x 100	-	-	-	-	-

DIMENSIONS in millimeters **AND AVAILABLE FORMS**

Note

(1) The MOQ for SLB-version is 5000 pieces

DIMENSIONS in millimeters, MASS AND PACKAGING QUANTITIES					
NOMINAL CASE SIZE Ø D x L	Ø D _{max.}	L _{max.}	MASS (g)	PACKAGING QUANTITIES (units per box)	CARDBOARD BOX DIMENSIONS L x W x H
25 x 30	26	32	≈ 24	100	290 x 280 x 50
25 x 40	26	42	≈ 28	100	290 x 280 x 60
30 x 40	31	42	≈ 38	100	340 x 330 x 60
35 x 40	36	42	≈ 51	50	390 x 198 x 60
35 x 50	36	52	≈ 66	50	390 x 198 x 70
40 x 50	41	52	≈ 82	50	440 x 223 x 70
40 x 70	41	72	≈ 110	25	230 x 230 x 90
40 x 100	41	102	≈ 176	25	230 x 230 x 120

MOUNTING

When a number of capacitors are connected in a bank, they must not be closer together than 15 mm, when no derating of ripple current and/or temperature is applied.

ELECTRICAL DATA	
SYMBOL	DESCRIPTION
C_R	rated capacitance at 100 Hz
I_R	rated RMS ripple current at 100 Hz, 85 °C or at 20 kHz, 70 °C
I_{L1}	max. leakage current after 1 minute at U_R
I_{L5}	max. leakage current after 5 minutes at U_R
ESR	max. equivalent series resistance at 100 Hz
Z	max. impedance at 10 kHz

Note

- Unless otherwise specified, all electrical values apply at $T_{amb} = 20\text{ °C}$, $P = 80\text{ kPa}$ to 120 kPa , $RH = 45\%$ to 75%

ORDERING EXAMPLE

EY01: 10 000 $\mu\text{F}/25\text{ V}$
Version 01: (no stud mounting)
Size: 35 mm x 50 mm
Ordering code: MALLEY01CD510E02W

EY02: 10 000 $\mu\text{F}/25\text{ V}$
Version 02: (stud mounting) ⁽¹⁾
Size: 35 mm x 50 mm
Ordering code: MALLEY02CD510E01W

Note

- ⁽¹⁾ MOQ for Version 02: 5000 pieces

ELECTRICAL DATA AND ORDERING INFORMATION									
U_R (V)	C_R 100 Hz (μF)	NOMINAL CASE SIZE $\varnothing D \times L$ (mm)	I_R 100 Hz 85 °C (A)	I_R 20 kHz 70 °C (A)	I_{L1} 1 min (mA)	I_{L5} 5 min (mA)	ESR 100 Hz ($\text{m}\Omega$)	Z 10 kHz ($\text{m}\Omega$)	ORDERING CODE
10	4700	25 x 30	2.4	4.6	0.28	0.10	74	50	MALLEY01AV447C02W
	6800	25 x 40	3.2	6.1	0.41	0.14	51	37	MALLEY01AB468C02W
	10 000	30 x 40	3.8	7.2	0.60	0.20	39	29	MALLEY01BB510C02W
	15 000	35 x 40	4.1	7.8	0.90	0.30	35	26	MALLEY01CB515C02W
	22 000	35 x 50	5.0	9.5	1.32	0.44	27	21	MALLEY01CD522C02W
	22 000	40 x 40	4.2	8.0	1.32	0.44	36	27	MALLEY01DB522C02W
	33 000	40 x 50	5.0	9.5	1.98	0.66	29	22	MALLEY01DD533C02W
	47 000	40 x 70	6.8	12.9	2.82	0.94	20	17	MALLEY01DG547C02W
68 000	40 x 100	9.2	17.5	4.08	1.36	15	14	MALLEY01DM568C02W	
16	3300	25 x 30	2.4	4.6	0.32	0.11	75	50	MALLEY01AV433D02W
	4700	25 x 40	3.1	5.9	0.45	0.15	52	37	MALLEY01AB447D02W
	6800	30 x 40	3.7	7.0	0.65	0.22	40	30	MALLEY01BB468D02W
	10 000	35 x 40	4.1	7.8	0.96	0.32	36	27	MALLEY01CB510D02W
	15 000	35 x 50	5.0	9.5	1.44	0.48	28	21	MALLEY01CD515D02W
	15 000	40 x 40	4.2	8.0	1.44	0.48	36	27	MALLEY01DB515D02W
	22 000	40 x 50	5.0	9.5	2.12	0.71	29	22	MALLEY01DD522D02W
	33 000	40 x 70	6.7	12.7	3.17	1.06	20	17	MALLEY01DG533D02W
47 000	40 x 100	9.1	17.3	4.51	1.51	15	14	MALLEY01DM547D02W	
25	2200	25 x 30	2.3	4.4	0.33	0.11	78	52	MALLEY01AV422E02W
	3300	25 x 40	3.1	5.9	0.49	0.17	53	38	MALLEY01AB433E02W
	4700	30 x 40	3.7	7.0	0.70	0.24	42	31	MALLEY01BB447E02W
	6800	35 x 40	4.1	7.8	1.02	0.34	37	28	MALLEY01CB468E02W
	10 000	35 x 50	5.0	9.5	1.50	0.50	28	21	MALLEY01CD510E02W
	10 000	40 x 40	4.2	8.0	1.50	0.50	36	27	MALLEY01DB510E02W
	15 000	40 x 50	5.0	9.5	2.25	0.75	29	22	MALLEY01DD515E02W
	22 000	40 x 70	6.8	12.9	3.30	1.10	20	17	MALLEY01DG522E02W
33 000	40 x 100	9.2	17.5	4.95	1.65	15	14	MALLEY01DM533E02W	
40	1500	25 x 30	2.0	3.8	0.36	0.12	112	68	MALLEY01AV415G02W
	2200	25 x 40	2.7	5.1	0.53	0.18	76	51	MALLEY01AB422G02W
	3300	30 x 40	3.3	6.3	0.79	0.27	57	41	MALLEY01BB433G02W
	4700	35 x 40	3.8	7.2	1.13	0.38	48	35	MALLEY01CB447G02W
	6800	35 x 50	4.7	8.9	1.64	0.55	36	27	MALLEY01CD468G02W
	6800	40 x 40	4.1	7.8	1.64	0.55	45	33	MALLEY01DB468G02W
	10 000	40 x 50	4.9	9.3	2.40	0.80	35	27	MALLEY01DD510G02W
	15 000	40 x 70	6.6	12.5	3.60	1.20	25	20	MALLEY01DG515G02W
22 000	40 x 100	9.0	17.1	5.28	1.76	18	16	MALLEY01DM522G02W	
63	1000	25 x 30	1.8	3.4	0.38	0.13	122	74	MALLEY01AV410J02W
	1500	25 x 40	2.5	4.7	0.57	0.19	83	54	MALLEY01AB415J02W
	2200	30 x 40	3.1	5.9	0.83	0.28	57	41	MALLEY01BB422J02W
	3300	35 x 40	3.6	6.8	1.25	0.42	48	35	MALLEY01CB433J02W
	4700	35 x 50	4.4	8.3	1.78	0.60	36	27	MALLEY01CD447J02W
	4700	40 x 40	3.8	7.2	1.78	0.60	45	33	MALLEY01DB447J02W
	6800	40 x 50	4.7	8.9	2.57	0.86	35	27	MALLEY01DD468J02W
	10 000	40 x 70	6.2	11.8	3.78	1.26	25	20	MALLEY01DG510J02W
15 000	40 x 100	8.5	16.1	5.67	1.89	18	16	MALLEY01DM515J02W	

ELECTRICAL DATA AND ORDERING INFORMATION

U_R (V)	C_R 100 Hz (μF)	NOMINAL CASE SIZE $\varnothing D \times L$ (mm)	I_R 100 Hz 85 °C (A)	I_R 20 kHz 70 °C (A)	I_{L1} 1 min (mA)	I_{L5} 5 min (mA)	ESR 100 Hz (m Ω)	Z 10 kHz (m Ω)	ORDERING CODE
100	470	25 x 30	1.4	2.7	0.28	0.10	247	172	MALLEY01AV347L02W
	680	25 x 40	1.9	3.6	0.41	0.14	170	116	MALLEY01AB368L02W
	1000	30 x 40	2.5	4.7	0.60	0.20	123	88	MALLEY01BB410L02W
	1500	35 x 40	3.1	5.8	0.90	0.30	94	71	MALLEY01CB415L02W
	2200	35 x 50	3.9	7.4	1.32	0.44	69	55	MALLEY01CD422L02W
	2200	40 x 40	3.6	6.8	1.32	0.44	81	65	MALLEY01DB422L02W
	3300	40 x 50	4.6	8.7	1.98	0.66	59	48	MALLEY01DD433L02W
	4700	40 x 70	6.2	11.7	2.82	0.94	42	36	MALLEY01DG447L02W
	6800	40 x 100	8.2	15.5	4.08	1.36	32	28	MALLEY01DM468L02W

ADDITIONAL ELECTRICAL DATA

PARAMETER	CONDITIONS	VALUE
Voltage		
Surge voltage	≤ 250 V versions	$U_s = 1.15 \times U_R$
Reverse voltage		$U_{rev} \leq 1$ V
Current		
Leakage current	After 1 minute at U_R	$I_{L1} \leq 0.006 C_R \times U_R + 4 \mu\text{A}$
	After 5 minutes at U_R	$I_{L5} \leq 0.002 C_R \times U_R + 4 \mu\text{A}$
Inductance		
Equivalent series inductance (ESL)	Case $\varnothing D = 25$ mm	max. 25 nH
	Case $\varnothing D = 30$ and 35 mm	max. 30 nH
	Case $\varnothing D = 40$ mm	max. 35 nH

LIFETIME TABLE rated voltage: ≤ 100 V

INTERRELATION BETWEEN ALTERNATING CURRENT, AMBIENT TEMPERATURE AND LIFETIME

I/I_R (frequency dependent)						SURFACE TEMPERATURE RISE ΔT_0 (°C)	LIFETIME MULTIPLIER (depending on I/I_R and T_{amb})									
FREQUENCY (Hz)							AMBIENT TEMPERATURE T_{amb} (°C)									
50	100	250	500	1000	> 2500	40	45	50	55	60	65	70	75	80	85	
0.19	0.20	0.21	0.22	0.22	0.23	0.2	63	40	26	17	11	7.3	5.0	3.4	2.3	1.63
0.38	0.40	0.42	0.43	0.45	0.47	0.7	55	35	23	15	9.9	6.7	4.5	3.1	2.2	1.51
0.56	0.60	0.63	0.65	0.67	0.70	1.5	45	29	19	13	8.5	5.7	3.9	2.7	1.9	1.33
0.75	0.80	0.84	0.86	0.89	0.94	2.5	35	23	15	10	6.9	4.7	3.3	2.3	1.6	1.13
0.94	1.00	1.05	1.08	1.12	1.17	3.8	26	17	12	7.9	5.4	3.7	2.6	1.8	1.3	1.00
1.13	1.20	1.26	1.29	1.34	1.41	5.4	18	13	8.6	5.9	4.1	2.9	2.0	1.4	1.0	
1.31	1.40	1.47	1.51	1.56	1.64	7.4	13	8.7	6.1	4.2	3.0	2.1	1.5	1.1		
1.50	1.60	1.68	1.72	1.79	1.87	9.6	8.3	5.9	4.2	3.0	2.1	1.5	1.1			
1.69	1.80	1.89	1.94	2.01	2.11	12	5.4	3.9	2.8	2.0	1.4	1.0				
1.88	2.00	2.10	2.15	2.23	2.34	15	3.4	2.5	1.8	1.3						
2.06	2.20	2.30	2.37	2.45	2.58	18	2.1	1.5	1.1							
2.25	2.40	2.51	2.58	2.68	2.81	21	1.2									

Notes
 I_R 100 Hz alternating current (A) at upper category temperature T_{UC} taken from datasheet

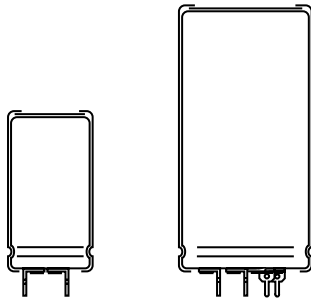
 I User current (A)

 T_{amb} Ambient temperature of capacitor (°C)

 ΔT_0 Surface temperature rise of capacitor caused by AC load (°C)

 L Lifetime multiplier

Aluminum Capacitors Power Printed Wiring Style



Component outlines

RoHS
COMPLIANT

FEATURES

- Polarized aluminum electrolytic capacitors, non-solid electrolyte
- Large types, minimized dimensions, cylindrical aluminum case, insulated with a blue sleeve
- Provided with keyed polarity
- Very long useful life: 5000 h at 105 °C
- Low ESR, high ripple current capability
- Temperature range up to 105 °C
- High resistance to shock and vibration

APPLICATIONS

- Computer, telecommunication and industrial systems
- Smoothing and filtering
- Standard and switched mode power supplies
- Energy storage in pulse systems

MARKING

The capacitors are marked (where possible) with the following information:

- Rated capacitance (in μF)
- Tolerance on rated capacitance, code letter in accordance with IEC 60062 (M for $\pm 20\%$)
- Rated voltage (in V)
- Date code (YYMM)
- Name of manufacturer
- Code for factory of origin
- Polarity of the terminals and '-' sign to indicate the negative terminal, visible from the top and/or side of the capacitor
- Code number
- Climatic category in accordance with IEC 60068

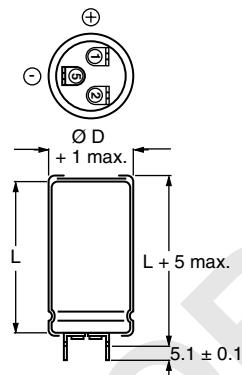
QUICK REFERENCE DATA

DESCRIPTION	VALUE	
Nominal case size (\varnothing D x L in mm)	25 x 30 to 40 x 100	
Rated capacitance range (E6 series), C_R	470 μF to 150 000 μF	68 μF to 3300 μF
Tolerance on C_R	$\pm 20\%$	
Rated voltage range, U_R	10 V to 100 V	200 V to 400 V
Category temperature range	- 40 °C to + 105 °C	
Endurance test at 105 °C	2000 h	
Useful life at 105 °C	5000 h	
Useful life at 40 °C, 1.9 x I_R applied	150 000 h	
Shelf life at 0 V, 105 °C	500 h	
Based on sectional specification	IEC 60384-4/EN130300	
Climatic category IEC 60068	40/105/56	

SELECTION CHART FOR C_R , U_R AND RELEVANT NOMINAL CASE SIZES (\varnothing D x L in mm)

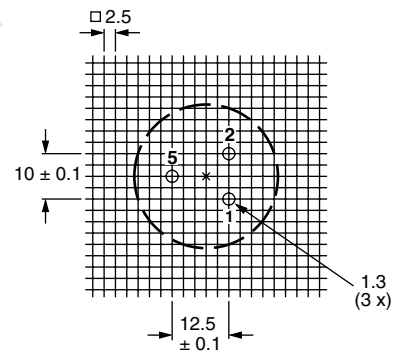
C_R (μF)	U_R (V)					
	10	16	25	40	63	100
470	-	-	-	-	-	25 x 30
680	-	-	-	-	-	25 x 40
1000	-	-	-	-	25 x 30	30 x 40
1500	-	-	-	-	25 x 40	35 x 40
2200	-	-	-	25 x 30	30 x 40	35 x 50
3300	-	-	-	25 x 40	35 x 40	40 x 40
4700	-	-	25 x 30	30 x 40	35 x 50	40 x 50
6800	-	-	-	-	40 x 40	-
10 000	-	25 x 30	25 x 40	35 x 40	40 x 50	40 x 100
15 000	25 x 30	25 x 40	30 x 40	35 x 50	40 x 70	-
22 000	25 x 40	30 x 40	35 x 40	40 x 40	-	-
33 000	30 x 40	35 x 40	35 x 50	40 x 50	40 x 100	-
47 000	35 x 40	35 x 50	40 x 50	40 x 70	-	-
68 000	35 x 50	40 x 40	-	-	-	-
100 000	40 x 40	40 x 50	40 x 70	-	-	-
150 000	40 x 50	40 x 70	40 x 100	-	-	-
	40 x 70	40 x 100	-	-	-	-
	40 x 100	-	-	-	-	-

SELECTION CHART FOR C_R, U_R AND RELEVANT NOMINAL CASE SIZES ($\varnothing D \times L$ in mm)				
C_R (μF)	U_R (V)			
	200	250	385	400
68	-	-	25 x 30	25 x 30
100	-	25 x 30	25 x 40	25 x 40
150	25 x 30	25 x 40	30 x 40	30 x 40
220	25 x 40	30 x 40	35 x 40	35 x 40
330	30 x 40	35 x 40	35 x 50	35 x 50
	-	-	40 x 40	40 x 40
470	35 x 40	35 x 50	40 x 50	40 x 50
	-	40 x 40	-	-
680	35 x 50	40 x 50	40 x 70	40 x 70
	40 x 50	-	-	-
1000	40 x 50	40 x 70	40 x 100	40 x 100
1500	40 x 70	40 x 100	-	-
2200	40 x 100	-	-	-

DIMENSIONS in millimeters AND AVAILABLE FORMS


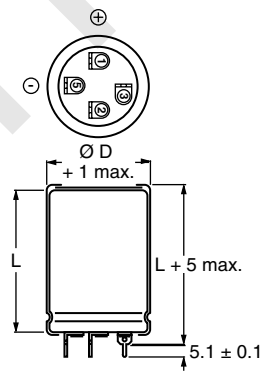
1 = Positive terminal
 5 = Negative terminal
 Case $\varnothing D = 25$ mm

Fig.1 Printed wiring pin version



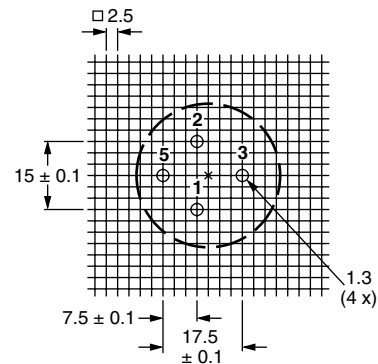
Case $\varnothing D = 25$ mm

Fig.2 Mounting hole pattern viewed from the component side



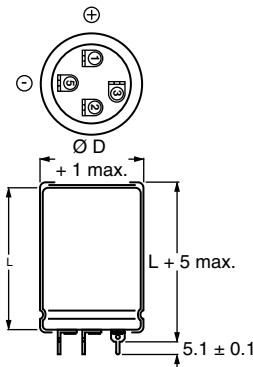
1 = Positive terminal
 5 = Negative terminal
 Case $\varnothing D = 30$ mm and 35 mm

Fig.3 Printed wiring pin version



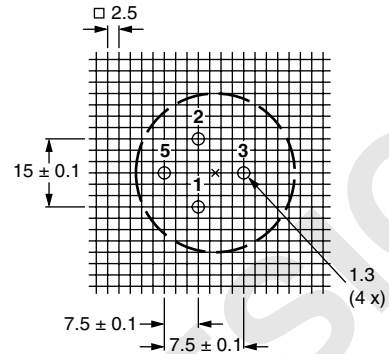
Case $\varnothing D = 30$ mm and 35 mm

Fig.4 Mounting hole pattern viewed from the component side



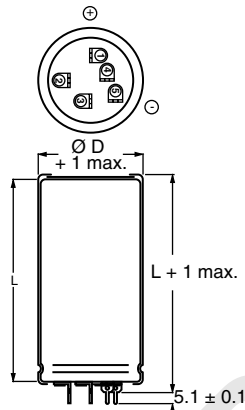
1 = Positive terminal;
5 = Negative terminal
Case Ø D = 35 mm

Fig.5 Printed wiring pin version



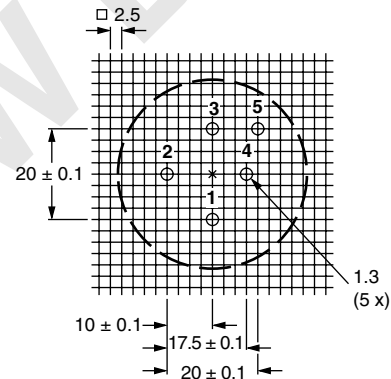
Case Ø D = 35 mm

Fig.6 Mounting hole pattern viewed from the component side



1 = Positive terminal;
5 = Negative terminal
Case Ø D = 40 mm

Fig.7 Printed wiring pin version



Case Ø D = 40 mm

Fig.8 Mounting hole pattern viewed from the component side

DIMENSIONS in millimeters, MASS AND PACKAGING QUANTITIES PW versions					
NOMINAL CASE SIZE Ø D x L	Ø D _{max.}	L _{max.}	MASS (g)	PACKAGING QUANTITIES (units per box)	CARDBOARD BOX DIMENSIONS L x W x H
25 x 30	26	35	≈ 24	100	290 x 280 x 50
25 x 40	26	45	≈ 28	100	290 x 280 x 60
30 x 40	31	45	≈ 38	100	340 x 330 x 60
35 x 40	36	45	≈ 51	50	390 x 198 x 60
35 x 50	36	55	≈ 66	50	390 x 198 x 70
40 x 40	41	45	≈ 78	50	440 x 223 x 60
40 x 50	41	55	≈ 82	50	440 x 223 x 70
40 x 70	41	75	≈ 110	25	230 x 230 x 90
40 x 100	41	105	≈ 176	25	230 x 230 x 120

MOUNTING

When a number of capacitors are connected in a bank, they must not be closer together than 15 mm, when no derating of ripple current and/or temperature is applied.

Pin numbers 2, 3 and 4 (if present) must be free from the electrical circuit.



Aluminum Capacitors
Power Printed Wiring Style

Vishay Roederstein

ELECTRICAL DATA	
SYMBOL	DESCRIPTION
C _R	rated capacitance at 100 Hz
I _R	rated RMS ripple current at 100 Hz and 105 °C
I _{L1}	max. leakage current after 1 minute at U _R
I _{L5}	max. leakage current after 5 minutes at U _R
ESR	max. equivalent series resistance at 100 Hz
Z	max. impedance at 10 kHz

ORDERING EXAMPLE

10 000 µF/25 V; ± 20 %

Nominal case size: Ø 30 x 40 mm

Ordering code: MALPEYZ00BB510E02W

Note

- Unless otherwise specified, all electrical values in tables 2 and 3 apply at T_{amb} = 20 °C, P = 86 kPa to 106 kPa, RH = 45 % to 75 %

ELECTRICAL DATA AND ORDERING INFORMATION								
U _R (V)	C _R 100 Hz (µF)	NOMINAL CASE SIZE Ø D x L (mm)	I _R 100 Hz 105 °C (A)	I _{L1} 1 min (mA)	I _{L5} 5 min (mA)	ESR 100 Hz (mΩ)	Z 10 kHz (mΩ)	ORDERING CODE
10	10 000	25 x 30	3.17	0.60	0.20	48	37	MALPEYZ00AV510C02W
	15 000	25 x 40	4.21	0.90	0.30	34	27	MALPEYZ00AB515C02W
	22 000	30 x 40	5.05	1.32	0.44	29	23	MALPEYZ00BB522C02W
	33 000	35 x 40	5.63	1.98	0.66	27	22	MALPEYZ00CB533C02W
	47 000	35 x 50	6.19	2.82	0.94	26	21	MALPEYZ00CD547C02W
	47 000	40 x 40	6.19	2.82	0.94	26	21	MALPEYZ00DB547C02W
	68 000	40 x 50	7.64	4.08	1.36	21	18	MALPEYZ00DD568C02W
	100 000	40 x 70	10.0	6.00	2.00	16	15	MALPEYZ00DG610C02W
	150 000	40 x 100	12.9	9.00	3.00	13	12	MALPEYZ00DM615C02W
16	6800	25 x 30	3.11	0.65	0.22	50	37	MALPEYZ00AV468D02W
	10 000	25 x 40	4.09	0.96	0.32	36	27	MALPEYZ00AB510D02W
	15 000	30 x 40	4.97	1.44	0.48	30	23	MALPEYZ00BB515D02W
	22 000	35 x 40	5.53	2.12	0.71	29	22	MALPEYZ00CB522D02W
	33 000	35 x 50	6.08	3.17	1.06	28	21	MALPEYZ00CD533D02W
	33 000	40 x 40	6.08	3.17	1.06	28	21	MALPEYZ00DB533D02W
	47 000	40 x 50	7.46	4.52	1.51	22	18	MALPEYZ00DD547D02W
	68 000	40 x 70	9.70	6.53	2.18	17	15	MALPEYZ00DG568D02W
	100 000	40 x 100	12.90	9.60	3.20	13	12	MALPEYZ00DM610D02W
25	4700	25 x 30	2.94	0.71	0.24	56	37	MALPEYZ00AV447E02W
	6800	25 x 40	3.93	1.02	0.34	39	27	MALPEYZ00AB468E02W
	10 000	30 x 40	4.81	1.50	0.50	32	23	MALPEYZ00BB510E02W
	15 000	35 x 40	5.43	2.25	0.75	30	22	MALPEYZ00CB515E02W
	22 000	35 x 50	5.98	3.30	1.10	29	21	MALPEYZ00CD522E02W
	22 000	40 x 40	5.98	3.30	1.10	29	21	MALPEYZ00DB522E02W
	33 000	40 x 50	7.30	4.95	1.65	23	18	MALPEYZ00DD533E02W
	47 000	40 x 70	9.43	7.05	2.35	18	15	MALPEYZ00DG547E02W
	68 000	40 x 100	12.44	10.20	3.40	14	12	MALPEYZ00DM568E02W
40	2200	25 x 30	2.36	0.53	0.18	87	54	MALPEYZ00AV422G02W
	3300	25 x 40	3.17	0.79	0.27	60	38	MALPEYZ00AB423G02W
	4700	30 x 40	3.93	1.13	0.38	48	33	MALPEYZ00BB447G02W
	6800	35 x 40	4.59	1.63	0.55	42	31	MALPEYZ00CB468G02W
	10 000	35 x 50	5.03	2.40	0.80	41	29	MALPEYZ00CD510G02W
	10 000	40 x 40	5.03	2.40	0.80	41	29	MALPEYZ00DB510G02W
	15 000	40 x 50	6.09	3.60	1.20	33	24	MALPEYZ00DD515G02W
	22 000	40 x 70	8.34	5.28	1.76	23	18	MALPEYZ00DG522G02W
	33 000	40 x 100	10.97	7.92	2.64	18	15	MALPEYZ00DM533G02W
63	1000	25 x 30	1.55	0.38	0.13	202	155	MALPEYZ00AV410J02W
	1500	25 x 40	2.10	0.57	0.19	137	109	MALPEYZ00AB415J02W
	2200	30 x 40	2.72	0.83	0.28	100	79	MALPEYZ00BB422J02W
	3300	35 x 40	3.44	1.25	0.42	75	61	MALPEYZ00CB433J02W
	4700	35 x 50	4.09	1.78	0.60	62	53	MALPEYZ00CD447J02W
	4700	40 x 40	4.09	1.78	0.60	62	53	MALPEYZ00DB447J02W
	6800	40 x 50	5.10	2.57	0.86	47	40	MALPEYZ00DD468J02W
	10 000	40 x 70	6.86	3.78	1.26	34	29	MALPEYZ00DG510J02W
	15 000	40 x 100	9.31	5.67	1.89	25	21	MALPEYZ00DM515J02W

ELECTRICAL DATA AND ORDERING INFORMATION

U_R (V)	C_R 100 Hz (μF)	NOMINAL CASE SIZE $\varnothing D \times L$ (mm)	I_R 100 Hz 105 °C (A)	I_{L1} 1 min (mA)	I_{L5} 5 min (mA)	ESR 100 Hz (m Ω)	Z 10 kHz (m Ω)	ORDERING CODE
100	470	25 x 30	1.42	0.28	0.10	240	155	MALPEYZ00AV347L02W
	680	25 x 40	1.90	0.41	0.14	167	109	MALPEYZ00AB368L02W
	1000	30 x 40	2.48	0.60	0.20	120	79	MALPEYZ00BB410L02W
	1500	35 x 40	3.17	0.90	0.30	88	61	MALPEYZ00CB415L02W
	2200	35 x 50	3.79	1.32	0.44	72	53	MALPEYZ00CD422L02W
	2200	40 x 40	3.79	1.32	0.44	72	53	MALPEYZ00DB422L02W
	3300	40 x 50	4.81	1.98	0.66	53	40	MALPEYZ00DD433L02W
	4700	40 x 70	6.49	2.82	0.94	38	29	MALPEYZ00DG447L02W
	6800	40 x 100	8.80	4.08	1.36	28	21	MALPEYZ00DM468L02W
200	150	25 x 30	0.72	0.18	0.06	950	710	MALPEYZ00AV315S02W
	220	25 x 40	0.96	0.26	0.09	650	485	MALPEYZ00AB322S02W
	330	30 x 40	1.29	0.40	0.14	442	330	MALPEYZ00BB333S02W
	470	35 x 40	1.66	0.57	0.19	321	240	MALPEYZ00CB347S02W
	680	35 x 50	2.09	0.82	0.28	237	185	MALPEYZ00CD368S02W
	680	40 x 40	2.09	0.82	0.28	237	185	MALPEYZ00DB368S02W
	1000	40 x 50	2.71	1.20	0.40	167	133	MALPEYZ00DD410S02W
	1500	40 x 70	3.75	1.80	0.60	114	90	MALPEYZ00DG415S02W
	2200	40 x 100	5.24	2.64	0.88	79	62	MALPEYZ00DM422S02W
250	100	25 x 30	0.67	0.15	0.05	1060	710	MALPEYZ00AV310N02W
	150	25 x 40	0.92	0.22	0.08	710	485	MALPEYZ00AB315N02W
	220	30 x 40	1.28	0.33	0.11	492	330	MALPEYZ00BB322N02W
	330	35 x 40	1.65	0.49	0.17	325	240	MALPEYZ00CB333N02W
	470	35 x 50	2.01	0.70	0.24	256	185	MALPEYZ00CD347N02W
	470	40 x 40	2.01	0.70	0.24	256	185	MALPEYZ00DB347N02W
	680	40 x 50	2.59	1.02	0.34	182	133	MALPEYZ00DD368N02W
	1000	40 x 70	3.58	1.50	0.50	125	90	MALPEYZ00DG410N02W
	1500	40 x 100	5.05	2.25	0.75	85	62	MALPEYZ00DM415N02W
385	68	25 x 30	0.61	0.16	0.06	1650	1260	MALPEYZ00AV268R02W
	100	25 x 40	0.82	0.23	0.08	1120	855	MALPEYZ00AB310R02W
	150	30 x 40	1.10	0.35	0.12	755	580	MALPEYZ00BB315R02W
	220	35 x 40	1.44	0.51	0.17	525	405	MALPEYZ00CB322R02W
	330	35 x 50	1.84	0.77	0.26	360	280	MALPEYZ00CD333R02W
	330	40 x 40	1.84	0.77	0.26	360	280	MALPEYZ00DB333R02W
	470	40 x 50	2.37	1.09	0.36	260	205	MALPEYZ00DD347R02W
	680	40 x 70	3.24	1.58	0.53	180	140	MALPEYZ00DG368R02W
	1000	40 x 100	4.54	2.31	0.78	125	100	MALPEYZ00DM410R02W
400	68	25 x 30	0.39	0.16	0.06	3200	2660	MALPEYZ00AV268X02W
	100	25 x 40	0.53	0.24	0.08	2180	1810	MALPEYZ00AB310X02W
	150	30 x 40	0.72	0.36	0.12	1460	1210	MALPEYZ00BB315X02W
	220	35 x 40	0.94	0.52	0.17	1010	830	MALPEYZ00CB322X02W
	330	35 x 50	1.24	0.79	0.26	680	570	MALPEYZ00CD333X02W
	330	40 x 40	1.24	0.79	0.26	680	570	MALPEYZ00DB333X02W
	470	40 x 50	1.59	1.12	0.37	485	407	MALPEYZ00DD347X02W
	680	40 x 70	2.18	1.63	0.54	336	282	MALPEYZ00DG368X02W
	1000	40 x 100	3.07	2.40	0.80	230	193	MALPEYZ00DM410X02W

ADDITIONAL ELECTRICAL DATA

PARAMETER	CONDITIONS	VALUE
Voltage		
Surge voltage	≤ 200 V versions	$U_s = 1.15 \times U_R$
	≥ 385 V versions	$U_s = 1.1 \times U_R$
Reverse voltage		$U_{rev} \leq 1$ V
Current		
Leakage current	After 1 minute at U_R	$I_{L1} \leq 0.006 C_R \times U_R + 4 \mu\text{A}$
	After 5 minutes at U_R	$I_{L5} \leq 0.002 C_R \times U_R + 4 \mu\text{A}$
Inductance		
Equivalent series inductance (ESL)	Case $\varnothing D = 25$ mm	max. 25 nH
	Case $\varnothing D = 30$ and 35 mm	max. 30 nH
	Case $\varnothing D = 40$ mm	max. 35 nH

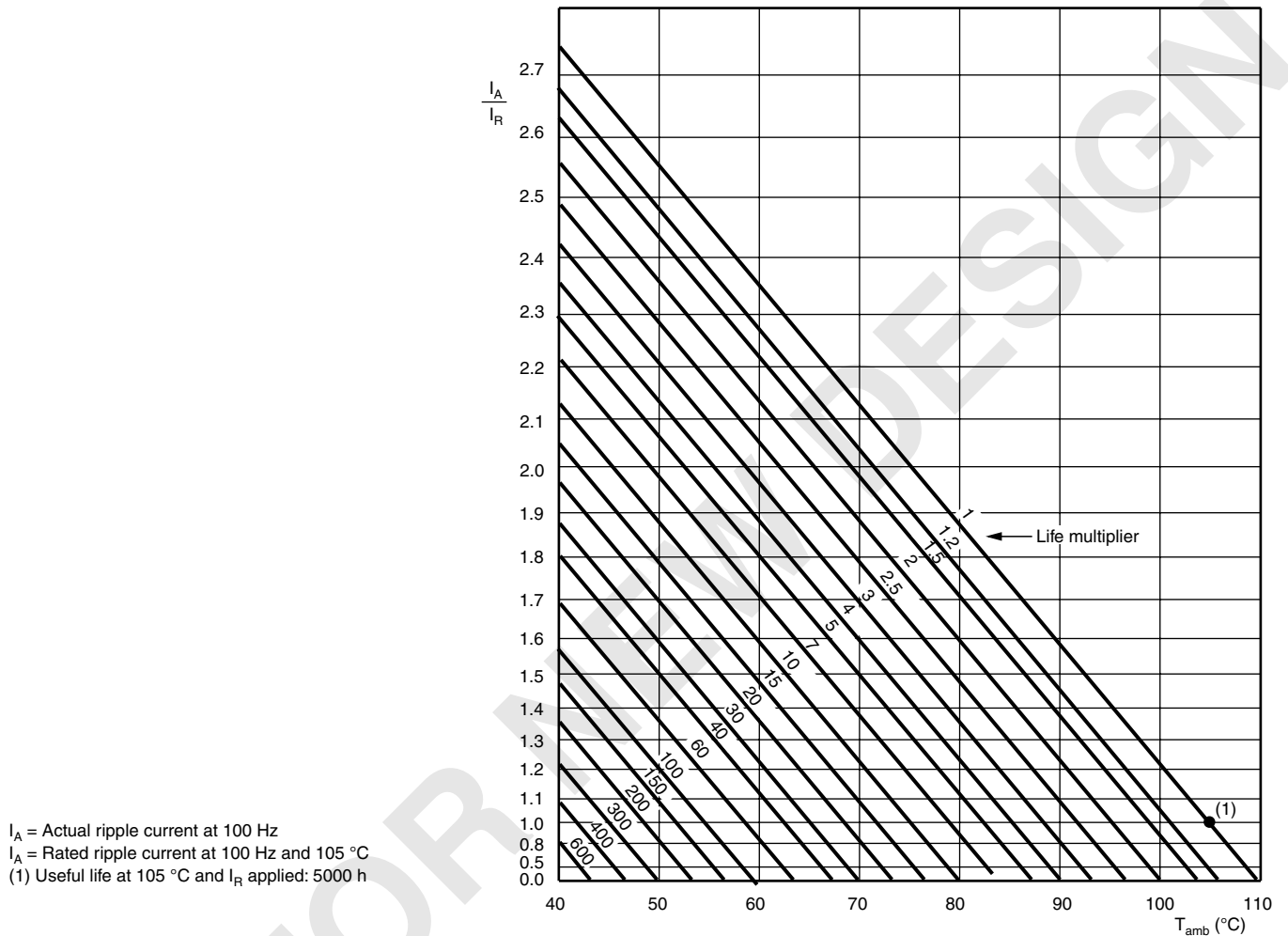
RIPPLE CURRENT AND USEFUL LIFE


Fig.9 Multiplier of useful life as a function of ambient temperature and ripple current load

MULTIPLIER OF RIPPLE CURRENT (I_R) AS A FUNCTION OF FREQUENCY			
FREQUENCY (Hz)	I_R MULTIPLIER		
	$U_R = 10\text{ V to }25\text{ V}$	$U_R = 40\text{ V to }100\text{ V}$	$U_R = 200\text{ V to }400\text{ V}$
50	0.93	0.91	0.86
100	1.00	1.00	1.00
200	1.04	1.05	1.13
400	1.07	1.09	1.21
1000	1.11	1.13	1.29
2000	1.13	1.15	1.32
4000	1.15	1.18	1.35
≥ 10 000	1.18	1.22	1.40

TEST PROCEDURES AND REQUIREMENT

TEST		PROCEDURE (quick reference)	REQUIREMENTS
NAME OF TEST	REFERENCE		
Endurance	IEC 60384-4/ EN130300 subclause 4.13	$T_{amb} = 105\text{ °C}$; U_R applied; 2000 h	$U_R \leq 100\text{ V}$; $\Delta C/C: \pm 15\%$ $U_R > 100\text{ V}$; $\Delta C/C: \pm 10\%$ $ESR \leq 1.3 \times \text{spec. limit}$ $Z \leq 2 \times \text{spec. limit}$ $I_{L5} \leq \text{spec. limit}$
Useful life	CECC 30301 subclause 1.8.1	$T_{amb} = 105\text{ °C}$; U_R and I_R applied; 5000 h	$U_R \leq 100\text{ V}$; $\Delta C/C: \pm 45\%$ $U_R > 100\text{ V}$; $\Delta C/C: \pm 30\%$ $ESR \leq 3 \times \text{spec. limit}$ $Z \leq 3 \times \text{spec. limit}$ $I_{L5} \leq \text{spec. limit}$ no short or open circuit, no visible damage total failure percentage: $U_R \leq 100\text{ V}: \leq 1\%$; $U_R > 100\text{ V}: \leq 3\%$
Shelf life (storage at high temperature)	IEC 60384-4/ EN130300 subclause 4.17	$T_{amb} = 105\text{ °C}$; no voltage applied; 500 h After test: U_R to be applied for 30 min, 24 h to 48 h before measurement	$\Delta C/C: \pm 10\%$ $ESR \leq 1.2 \times \text{spec. limit}$ $I_{L5} \leq 2 \times \text{spec. limit}$



Vishay Sprague

Contents

80D	258
82D	262
82DA	267
81D	270
81DA	274
36DY	277
36D, 36DE, 36DX	283
36DA	288

Aluminum Capacitors + 85 °C, Snap-In

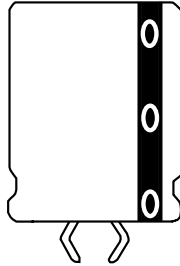


Fig.1 Component Outlines

FEATURES

- High ripple capability
- Molded cover available in 2 and 3 terminal design with standoffs



RoHS
COMPLIANT

QUICK REFERENCE DATA	
DESCRIPTION	VALUE
Nominal case size Ø D x L in inches (mm)	1.38 x 3.15 (35.0 x 80.0)
Operating temperature	- 40 °C to + 85 °C
Rated capacitance range, C _R	82 µF to 56 000 µF
Tolerance on C _R	- 10 %, + 30 %
Rated voltage range, U _R	6.3 WVDC to 250 WVDC
Termination	Snap mount or 2 and 3 terminal straight leads
Life validation test at 85 °C	2000 h: ΔCAP ≤ 15 % from initial measurement. ΔESR ≤ 1.5 x initial specified limit. ΔDCL ≤ initial specified limit
Shelf life at 85 °C	500 h: ΔCAP ≤ 15 % from initial measurement. ΔESR ≤ 1.3 x initial specified limit. ΔDCL ≤ 2 x initial specified limit
DC leakage current	$I = K \sqrt{CV}$ K = 4.0 at + 25 °C I in µA, C in µF, V in Volts

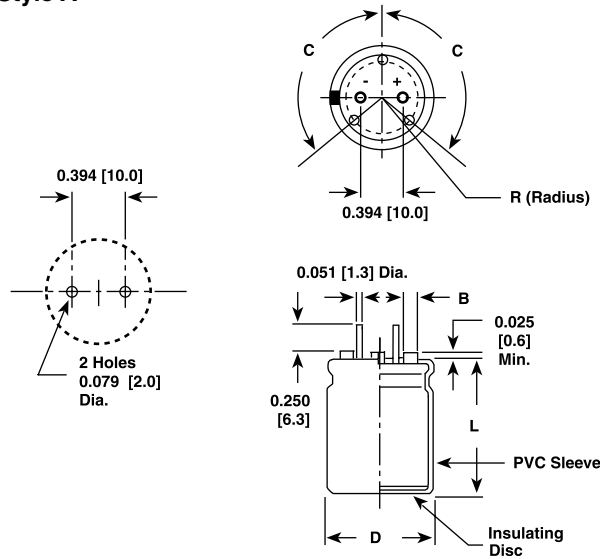
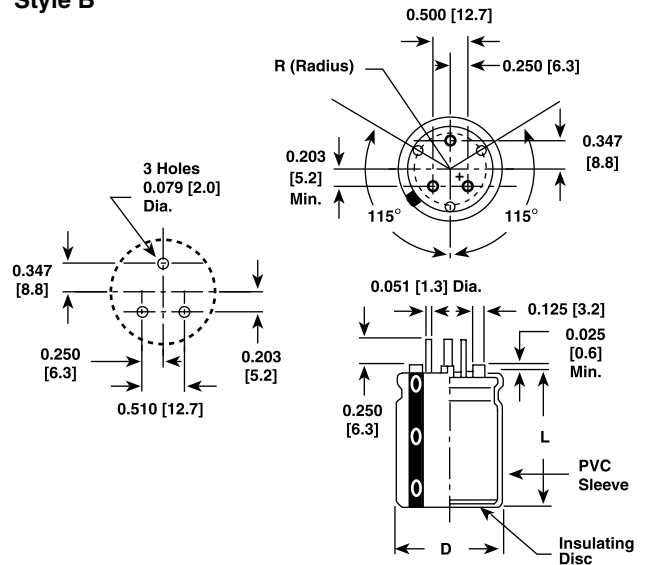
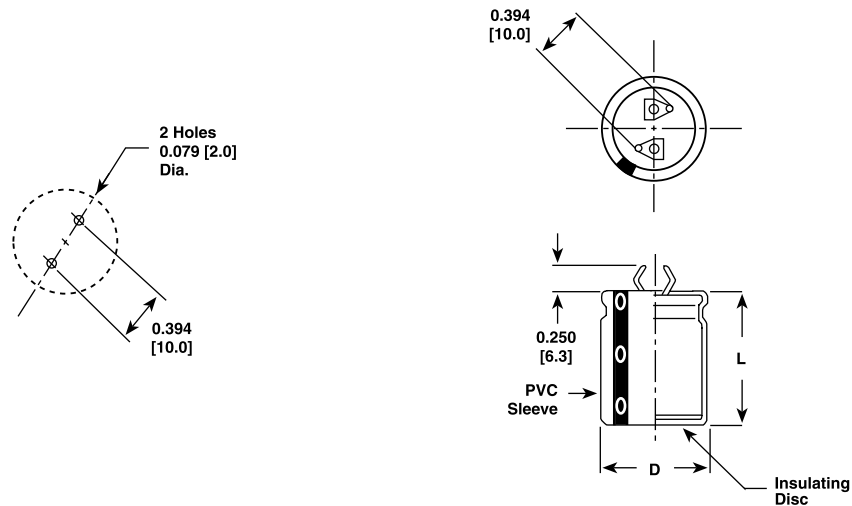
RIPPLE CURRENT MULTIPLIERS			
TEMPERATURE			
AMBIENT TEMPERATURE	MULTIPLIERS		
- 55 °C	2.0		
- 65 °C	1.7		
- 75 °C	1.4		
- 85 °C	1.0		
FREQUENCY (Hz)			
WVDC	50 TO 60	300 TO 1000	1000 AND UP
0 to 49	0.85	1.10	1.15
50 to 199	0.83	1.15	1.20
200 to 250	0.80	1.30	1.40
ESL (TYPICAL VALUES AT 1 MHz TO 10 MHz)			
Nominal Diameter	0.984 (25.0)	1.18 (30.0)	1.38 (35.0)
Typical ESL (nH)	8.0	10.0	12.0

DIMENSIONS in inches (millimeters)									
CASE CODE	DIAMETER		LENGTH		CASE CODE	DIAMETER		LENGTH	
	D + 0.039 - 0 (+ 1.0 - 0)		L ± 0.079 (2.0)			D + 0.039 - 0 (+ 1.0 - 0)		L ± 0.079 (2.0)	
JA	1.00 (25.0)		1.00 (25.0)		KD	1.18 (30.0)		1.57 (40.0)	
JB	1.00 (25.0)		1.18 (30.0)		KE	1.18 (30.0)		2.00 (50.0)	
JC	1.00 (25.0)		1.38 (35.0)		MB	1.38 (35.0)		1.18 (30.0)	
JD	1.00 (25.0)		1.57 (40.0)		MC	1.38 (35.0)		1.38 (35.0)	
JE	1.00 (25.0)		2.00 (50.0)		MD	1.38 (35.0)		1.57 (40.0)	
KA	1.18 (30.0)		1.00 (25.0)		ME	1.38 (35.0)		2.00 (50.0)	
KB	1.18 (30.0)		1.18 (30.0)		MF	1.38 (35.0)		2.50 (63.0)	
KC	1.18 (30.0)		1.38 (35.0)		MG	1.38 (35.0)		3.18 (80.0)	

DIMENSIONS in inches (millimeters)					
CIRCUIT BOARD MOUNT TERMINAL DIMENSIONS					
DIAMETER		STYLE A			STYLE B
D	CASE CODE	B	R	C	R
1.00 (25.0)	J	0.093 (2.4)	0.301 (7.6)	140°	N/A
1.18 (30.0)	K	0.125 (2.3)	0.363 (9.2)	120°	0.391 (9.9) ⁽¹⁾
1.38 (35.0)	M	0.125 (3.2)	0.458 (11.6)	120°	0.458 (11.6) ⁽¹⁾

Notes

⁽¹⁾ Pin-type molded cover available on 80D/82D through 450 V. For 81D, only up through 250 V.

DIMENSIONAL AND AVAILABLE FORMS
Style A

Style B

Style D


ORDERING EXAMPLE

Electrolytic capacitor 80D series:

80D 122 P 200 ME 2 D E3

DESCRIPTION	
CODE	EXPLANATION
80D	Product type
122	Capacitance value (1200 μ F)
P	Tolerance (P = - 10 %/+ 30 %)
200	Voltage rating at 85 °C (200 V)
MA	Can size (see dimensions table)
2	PVC insulating sleeve
D	Terminal style (D = 2 pin snap-in)
E3	RoHS compliant

ELECTRICAL DATA AND ORDERING INFORMATION						
CAPACITANCE (μ F)	PART NUMBER	NOMINAL CASE SIZE D x L	MAX. ESR		MAX. RIPPLE at + 85 °C (A)	
			120 Hz	10 kHz to 40 kHz	120 Hz	10 kHz to 40 kHz
16 WVDC at + 85 °C, SURGE = 20 V						
8200.0	80D822P016JB2DE3	0.984 x 1.18 (25.0 x 30.0)	73.0	65.0	3.3	3.6
8200.0	80D822P016KA2DE3	1.18 x 0.984 (30.0 x 25.0)	91.0	84.0	2.8	3.0
10 000.0	80D103P016JC2DE3	0.984 x 1.38 (25.0 x 35.0)	59.0	53.0	3.9	4.2
15 000.0	80D153P016JE2DE3	0.984 x 1.97 (25.0 x 50.0)	37.0	33.0	5.6	6.0
22 000.0	80D223P016KE2DE3	1.18 x 1.97 (30.0 x 50.0)	35.0	32.0	5.8	6.1
33 000.0	80D333P016ME2DE3	1.38 x 1.97 (35.0 x 50.0)	19.0	17.0	9.4	10.0
25 WVDC at + 85 °C, SURGE = 30 V						
4700.0	80D427P025JB2DE3	0.984 x 1.18 (25.0 x 30.0)	76.0	65.0	3.2	3.6
6800.0	80D682P025KB2DE3	1.18 x 1.18 (30.0 x 30.0)	71.0	63.0	3.4	3.6
10 000.0	80D103P025JE2DE3	0.984 x 1.97 (25.0 x 50.0)	39.0	33.0	5.4	6.0
10 000.0	80D103P025MB2DE3	1.38 x 1.18 (35.0 x 30.0)	38.0	33.0	5.5	6.2
15 000.0	80D153P025KE2DE3	1.18 x 1.97 (30.0 x 50.0)	36.0	32.0	5.7	6.1
22 000.0	80D223P025ME2DE3	1.38 x 1.97 (35.0 x 50.0)	19.0	17.0	9.1	10.0
35 WVDC at + 85 °C, SURGE = 44 V						
4700.0	80D472P035KB2DE3	1.18 x 1.18 (30.0 x 30.0)	-	-	-	-
6800.0	80D682P035KC2DE3	1.18 x 1.38 (30.0 x 35.0)	60.0	51.0	3.8	4.2
10 000.0	80D103P035MC2DE3	1.38 x 1.38 (35.0 x 35.0)	33.0	27.0	6.2	7.2
12 000.0	80D123P035KE2DE3	1.38 x 1.38 (35.0 x 35.0)	33.0	27.0	6.2	7.2
15 000.0	80D153P035ME2DE3	1.38 x 1.97 (35.0 x 35.0)	20.0	17.0	8.8	10.0
50 WVDC at + 85 °C, SURGE = 63 V						
3300.0	80D332P050JD2DE3	0.984 x 1.57 (25.0 x 40.0)	57.0	42.0	3.9	4.9
3300.0	80D332P050KB2DE3	1.18 x 1.18 (30.0 x 30.0)	79.0	63.0	3.1	3.6
4700.0	80D472P050KD2DE3	1.18 x 1.57 (30.0 x 40.0)	51.0	41.0	4.3	4.9
6800.0	80D682P050KE2DE3	1.18 x 1.97 (30.0 x 50.0)	40.0	32.0	5.3	6.1
63 WVDC at + 85 °C, SURGE = 79 V						
1500.0	80D152P063JB2DE3	0.984 x 1.18 (25.0 x 30.0)	82.0	55.0	2.8	3.8
2200.0	80D222P063KB2DE3	1.18 x 1.18 (30.0 x 30.0)	72.0	54.0	3.2	3.9
3300.0	80D332P063MB2DE3	1.38 x 1.18 (35.0 x 30.0)	40.0	28.0	5.0	6.6
4700.0	80D472P063KE2DE3	1.18 x 1.97 (30.0 x 50.0)	36.0	28.0	5.4	6.4
6800.0	80D682P063ME2DE3	1.38 x 1.97 (35.0 x 50.0)	21.0	15.0	8.3	10.0



Aluminum Capacitors
+ 85 °C, Snap-In

Vishay Sprague

ELECTRICAL DATA AND ORDERING INFORMATION						
CAPACITANCE (µF)	PART NUMBER	NOMINAL CASE SIZE D x L	MAX. ESR		MAX. RIPPLE at + 85 °C (A)	
			120 Hz	10 kHz to 40 kHz	120 Hz	10 kHz to 40 kHz
100 WVDC at + 85 °C, SURGE = 125 V						
680.0	80D681P100JB2DE3	0.984 x 1.18 (25.0 x 30.0)	139.0	85.0	2.2	3.5
1000.0	80D102P100KB2DE3	1.18 x 1.18 (30.0 x 30.0)	111.0	74.0	2.7	3.7
1500.0	80D152P100JE2DE3	0.984 x 1.97 (25.0 x 25.0)	68.0	42.0	3.9	5.9
2200.0	80D222P100KE2DE3	1.18 x 1.97 (30.0 x 50.0)	55.0	37.0	4.7	6.2
3300.0	80D332P100ME2DE3	1.38 x 1.97 (35.0 x 50.0)	50.0	37.0	5.2	6.2
200 WVDC at + 85 °C, SURGE = 250 V						
150.0	80D151P200JA2DE3	0.984 x 0.984 (25.0 x 25.0)	660.0	375.0	1.3	3.2
220.0	80D221P200KA2DE3	1.18 x 0.984 (30.0 x 25.0)	460.0	272.0	1.7	3.6
330.0	80D331P200KC2DE3	1.18 x 1.38 (30.0 x 35.0)	278.0	165.0	2.4	4.9
470.0	80D471P200KD2DE3	1.18 x 1.57 (30.0 x 40.0)	220.0	131.0	2.8	5.7
680.0	80D681P200KD2DE3	1.18 x 1.57 (30.0 x 40.0)	248.0	127.0	2.1	4.7
820.0	80D821P200ME2DE3	1.38 x 1.97 (35.0 x 35.0)	130.0	82.0	4.3	7.4
1000.0	80D102P200ME2DE3	1.38 x 1.97 (35.0 x 50.0)	144.0	81.0	3.4	6.6
1200.0	80D122P200ME2DE3	1.38 x 1.97 (35.0 x 50.0)	141.0	75.0	3.4	6.6
250 WVDC at + 85 °C, SURGE = 300 V						
100.0	80D101P250JA2DE3	0.984 x 0.984 (25.0 x 25.0)	720.0	377.0	1.1	3.2
150.0	80D151P250JB2DE3	0.984 x 1.18 (25.0 x 30.0)	541.0	284.0	1.4	3.8
220.0	80D221P250JD2DE3	0.984 x 1.57 (25.0 x 40.0)	343.0	182.0	2.0	5.2
330.0	80D331P250JE2DE3	0.984 x 1.97 (25.0 x 50.0)	263.0	140.0	2.5	6.3
470.0	80D471P250KE2DE3	1.18 x 1.97 (30.0 x 50.0)	185.0	101.0	3.2	7.0
680.0	80D681P250ME2DE3	1.38 x 1.97 (35.0 x 50.0)	191.0	81.0	4.0	7.4

Notes

* Some Inventory may include PVC sleeve with resin end seal (5D).
Additional Part Numbers normally found in distribution inventory include:

80D102P100JD2DE3	80D222P063JD2DE3	80D391P200MB2DE3	80D472P050JC2DE3
80D102P200MD2DE3	80D222P080JE2DE3	80D392P050JE2DE3	80D682P035MB2DE3
80D103P035KE2DE3	80D223P010MB2DE3	80D472P050JC2DE3	80D682P050MD2DE3
80D123P016KB2DE3	80D272P035HB2DE3	80D472P050JE2DE3	80D822P025JD2DE3
80D152P050JA2DE3	80D272P035JA2DE3	80D472P050MB2DE3	80D822P035MB2DE3
80D153P016MB2DE3	80D332P063JE2DE3	80D681P200MD2DE3	80D822P050ME2DE3
80D222P050KA2DE3	80D333P010KE2DE3	80D682P035JE2DE3	

• Other capacitance values are available on request. Call for a quotation for price and delivery.

Aluminum Capacitors + 85 °C, Snap-In, General Purpose

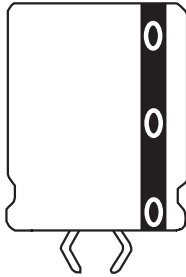


Fig. 1 Component Outlines

FEATURES

- Economical
- General purpose design
- Wide voltage range



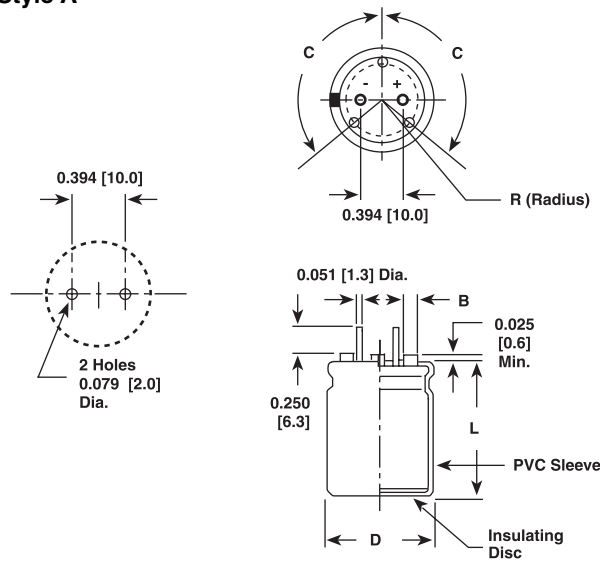
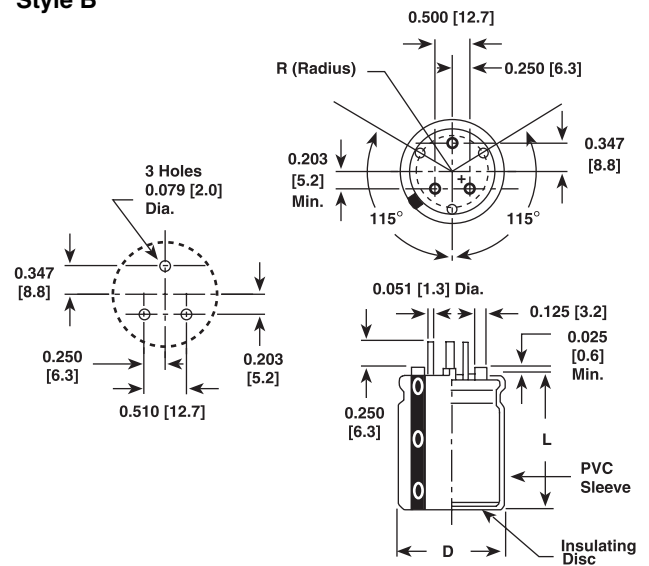
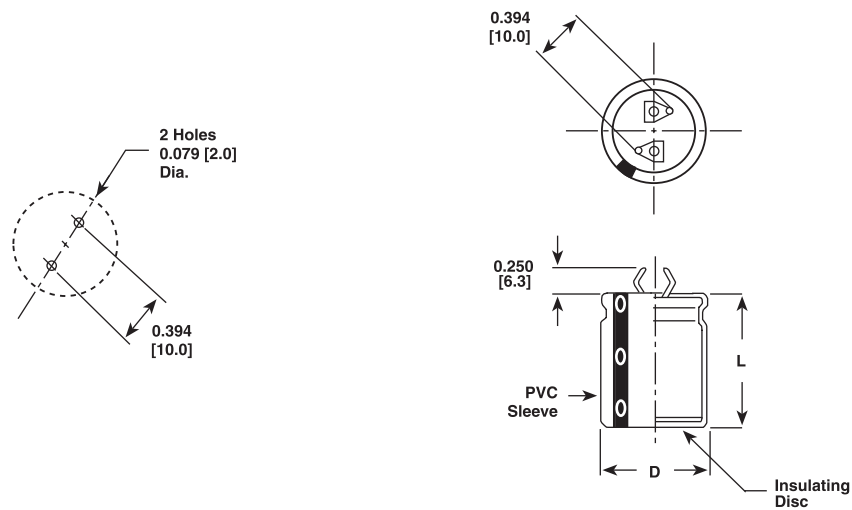
RoHS
COMPLIANT

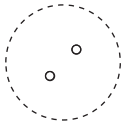
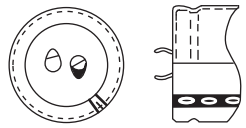
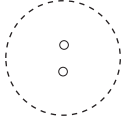
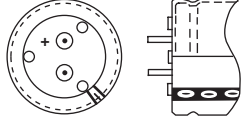
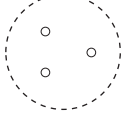
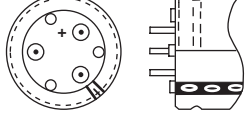
QUICK REFERENCE DATA	
DESCRIPTION	VALUE
Nominal case size Ø D x L in inches (mm)	1.38 x 3.15 (35.0 x 80.0)
Operating temperature	- 40 °C to + 85 °C
Rated capacitance range, C _R	39 µF to 180 000 µF
Tolerance on C _R	± 20 %
Rated voltage range, U _R	6.3 WVDC to 450 WVDC
Termination	Snap-in
Life validation test at 85 °C	2000 h: ΔCAP ≤ 15 % from initial measurement. ΔESR ≤ 1.5 x initial specified limit. ΔDCL ≤ initial specified limit
Shelf life at 85 °C	500 h: ΔCAP ≤ 15 % from initial measurement. ΔESR ≤ 1.3 x initial specified limit. ΔDCL ≤ 2 x initial specified limit
DC leakage current	$I = K \cdot \sqrt{CV}$ K = 4.0 at + 25 °C I in µA, C in µF, V in Volts

RIPPLE CURRENT MULTIPLIERS			
TEMPERATURE			
AMBIENT TEMPERATURE		MULTIPLIERS	
- 55 °C		2.0	
- 65 °C		1.7	
- 75 °C		1.4	
- 85 °C		1.0	
FREQUENCY (Hz)			
WVDC	50 TO 60	300 TO 1000	1000 AND UP
16 to 49	0.85	1.10	1.15
50 to 199	0.83	1.15	1.20
200 to 400	0.80	1.30	1.40
ESL (TYPICAL VALUES AT 1 MHz TO 10 MHz)			
Nominal Diameter	0.98 (25.0)	1.18 (30.0)	1.38 (35.0)
Typical ESL (nH)	8.0	10.0	12.0

DIMENSIONS in inches (millimeters)									
CASE CODE	DIAMETER		LENGTH		CASE CODE	DIAMETER		LENGTH	
	D + 0.04 - 0 (+ 1.0 - 0)		L ± 0.08 (2.0)			D + 0.04 - 0 (+ 1.0 - 0)		L ± 0.08 (2.0)	
JA	1.00 (25.0)		1.00 (25.0)		KD	1.18 (30.0)		1.57 (40.0)	
JB	1.00 (25.0)		1.18 (30.0)		KE	1.18 (30.0)		2.00 (50.0)	
JC	1.00 (25.0)		1.38 (35.0)		MB	1.38 (35.0)		1.18 (30.0)	
JD	1.00 (25.0)		1.57 (40.0)		MC	1.38 (35.0)		1.38 (35.0)	
JE	1.00 (25.0)		2.00 (50.0)		MD	1.38 (35.0)		1.57 (40.0)	
KA	1.18 (30.0)		1.00 (25.0)		ME	1.38 (35.0)		2.00 (50.0)	
KB	1.18 (30.0)		1.18 (30.0)		MF	1.38 (35.0)		2.50 (63.0)	
KC	1.18 (30.0)		1.38 (35.0)		MG	1.38 (35.0)		3.18 (80.0)	

DIMENSIONS in inches (millimeters)					
CIRCUIT BOARD MOUNT TERMINAL DIMENSIONS					
DIAMETER		STYLE A			STYLE B
D	CASE CODE	B	R	C	R
1.00 (25.0)	J	0.093 (2.4)	0.301 (7.6)	140°	N/A
1.18 (30.0)	K	0.125 (3.2)	0.363 (9.2)	120°	0.391 (9.9)
1.38 (35.0)	M	0.125 (3.2)	0.458 (11.6)	120°	0.458 (11.6)

DIMENSIONS AND AVAILABLE FORMS
Style A

Style B

Style D


TERMINAL CONFIGURATION in inches (millimeters)					
LEAD CODE	DESCRIPTION	OUTLINE DRAWINGS		AVAILABLE DIAMETERS	AVAILABLE VOLTAGES AND TYPES
		MOUNTING CONFIGURATION	TERMINAL CONFIGURATION		
D	Standard 2 pin snap-in			0.98 (25.0) - J 1.18 (30.0) - K 1.38 (35.0) - M	All voltages 81D, 81DA 82D, 82DA
A	2 straight wire lead molded cover with standoffs			0.98 (25.0) - J 1.18 (30.0) - K 1.38 (35.0) - M	All voltages 82D, 82DA $V \leq 250 V_{DC}$ 81D, 81DA
B	3 straight wire lead molded cover with standoffs			1.18 (30.0) - K 1.38 (35.0) - M	All voltages 82D, 82DA $V \leq 250 V_{DC}$ 81D, 81DA

ORDERING EXAMPLE

Electrolytic capacitor 82D series:

82D 122 M 050 HA 2 D E3

DESCRIPTION	
CODE	EXPLANATION
82D	Product type
122	Capacitance value (1200 μ F)
M	Tolerance (M = ± 20 %)
050	Voltage rating at 85 °C (50 V)
HA	Can size (see dimensions table)
2	PVC insulating sleeve
D	Terminal style (D = 2 pin snap-in)
E3	RoHS compliant

ELECTRICAL DATA AND ORDERING INFORMATION						
CAPACITANCE (μ F)	PART NUMBER	NOMINAL CASE SIZE D x L	MAX. ESR at 25 °C (m Ω)		MAX. RIPPLE at + 85 °C (A)	
			120 Hz	20 kHz to 40 kHz	120 Hz	20 kHz to 40 kHz
16 WVDC at + 85 °C, SURGE = 20 V						
15 000.0	82D153M016JC2DE3	0.984 x 1.378 (25.0 x 35.0)	58.0	43.0	3.33	3.87
22 000.0	82D223M016KB2DE3	1.181 x 1.181 (30.0 x 30.0)	53.7	41.0	3.70	4.20
33 000.0	82D333M016KD2DE3	1.181 x 1.575 (30.0 x 40.0)	35.3	27.0	5.00	5.77
33 000.0	82D333M016MC2DE3	1.378 x 1.378 (35.0 x 35.0)	28.0	21.0	5.96	6.87
47 000.0	82D473M016MD2DE3	1.378 x 1.575 (35.0 x 40.0)	23.0	17.0	6.86	6.65
25 WVDC at + 85 °C, SURGE = 30 V						
6800.0	82D682M025JB2DE3	0.984 x 1.181 (25.0 x 30.0)	67.0	47.0	2.94	3.49
10 000.0	82D103M025JD2DE3	0.984 x 1.545 (25.0 x 40.0)	43.4	31.0	4.22	4.96
15 000.0	82D153M025JE2DE3	0.984 x 1.969 (25.0 x 50.0)	33.9	24.0	4.97	5.96



Aluminum Capacitors
+ 85 °C, Snap-In, General Purpose

Vishay Sprague

ELECTRICAL DATA AND ORDERING INFORMATION						
CAPACITANCE (μ F)	PART NUMBER	NOMINAL CASE SIZE D x L	MAX. ESR at 25 °C (m Ω)		MAX. RIPPLE at + 85 °C (A)	
			120 Hz	20 kHz to 40 kHz	120 Hz	20 kHz to 40 kHz
25 WVDC at + 85 °C, SURGE = 30 V						
6800.0	82D682M025KA2DE3	1.181 x 0.984 (30.0 x 25.0)	71.0	54.0	3.00	3.47
10 000.0	82D103M025KB2DE3	1.181 x 1.181 (30.0 x 30.0)	54.0	41.0	3.70	4.20
15 000.0	82D153M025KD2DE3	1.181 x 1.575 (30.0 x 40.0)	36.4	27.0	5.00	5.77
22 000.0	82D223M025MD2DE3	1.378 x 1.575 (35.0 x 40.0)	23.0	17.0	6.84	7.96
35 WVDC at + 85 °C, SURGE = 40 V						
4700.0	82D472M035JB2DE3	0.984 x 1.181 (25.0 x 30.0)	72.0	47.0	2.82	3.49
6800.0	82D682M035JD2DE3	0.984 x 1.575 (25.0 x 40.0)	46.6	30.0	4.08	5.08
10000.0	82D103M035JE2DE3	0.984 x 1.969 (25.0 x 50.0)	36.3	24.0	4.87	5.96
4700.0	82D472M035KA2DE3	1.181 x 0.984 (30.0 x 25.0)	75.0	54.0	2.92	3.42
12 000.0	82D123M035KD2DE3	1.181 x 1.575 (30.0 x 40.0)	37.7	27.0	4.89	5.77
10 000.0	82D103M035MB2DE3	1.378 x 1.181 (35.0 x 30.0)	36.0	24.0	4.97	6.10
15 000.0	82D153M035MD2DE3	1.378 x 1.575 (35.0 x 40.0)	25.0	16.3	6.57	8.13
50 WVDC at + 85 °C, SURGE = 63 V						
2200.0	82D222M050JB2DE3	0.984 x 1.181 (25.0 x 30.0)	85.0	48.0	2.61	3.49
3900.0	82D392M050JD2DE3	0.984 x 1.575 (25.0 x 40.0)	53.6	31.0	3.79	4.96
2700.0	82D272M050KA2DE3	1.181 x 0.984 (30.0 x 25.0)	85.0	54.0	2.73	3.42
4700.0	82D472M050MB2DE3	1.378 x 1.181 (35.0 x 30.0)	43.0	24.0	4.56	6.10
6800.0	82D682M050MD2DE3	1.378 x 1.575 (35.0 x 40.0)	28.0	16.0	6.21	8.21
10 000.0	82D103M050ME2DE3	1.378 x 1.969 (35.0 x 50.0)	22.0	13.0	7.60	9.87
63 WVDC at + 85 °C, SURGE = 79 V						
1500.0	82D152M063JA2DE3	0.984 x 0.984 (25.0 x 25.0)	121.0	63.0	2.05	2.86
2200.0	82D222M063JC2DE3	0.984 x 1.378 (25.0 x 35.0)	72.0	38.0	2.97	4.09
3300.0	82D332M063JD2DE3	0.984 x 1.575 (25.0 x 40.0)	57.0	30.0	3.69	5.08
3300.0	82D332M063KB2DE3	1.181 x 1.181 (30.0 x 30.0)	68.0	41.0	3.28	4.20
6800.0	82D682M063KE2DE3	1.181 x 1.969 (30.0 x 50.0)	34.0	22.0	5.56	6.89
4700.0	82D472M063MC2DE3	1.378 x 1.378 (35.0 x 35.0)	36.0	20.0	5.24	7.04
100 WVDC at + 85 °C, SURGE = 125 V						
680.0	82D681M100JB2DE3	0.984 x 1.181 (25.0 x 30.0)	188.0	86.0	1.75	2.59
1000.0	82D102M100KB2DE3	1.181 x 1.181 (30.0 x 30.0)	136.0	66.0	2.31	3.31
1500.0	82D152M100KC2DE3	1.181 x 1.378 (30.0 x 35.0)	106.0	52.0	2.75	3.95
2200.0	82D222M100KE2DE3	1.181 x 1.969 (30.0 x 50.0)	66.0	33.0	4.02	5.69
200 WVDC at + 85 °C, SURGE = 250 V						
220.0	82D221M200JA2DE3	0.984 x 0.984 (25.0 x 25.0)	625.0	272.0	0.967	1.46
470.0	82D471M200JD2DE3	0.984 x 1.575 (25.0 x 40.0)	271.0	121.0	1.79	2.68
330.0	82D331M200KA2DE3	1.181 x 0.984 (30.0 x 25.0)	498.0	192.0	1.21	1.96
470.0	82D471M200KB2DE3	1.181 x 1.181 (30.0 x 30.0)	294.0	136.0	1.64	2.48
680.0	82D681M200KD2DE3	1.181 x 1.575 (30.0 x 40.0)	221.0	87.0	2.14	3.41
1000.0	82D102M200KE2DE3	1.181 x 1.969 (30.0 x 50.0)	142.0	67.0	2.89	4.22
820.0	82D821M200MC2DE3	1.378 x 1.378 (35.0 x 35.0)	189.0	93.0	2.46	3.51
1000.0	82D102M200MD2DE3	1.378 x 1.575 (35.0 x 40.0)	149.0	74.0	2.88	3.41



ELECTRICAL DATA AND ORDERING INFORMATION						
CAPACITANCE (μ F)	PART NUMBER	NOMINAL CASE SIZE D x L	MAX. ESR at 25 °C (m Ω)		MAX. RIPPLE at + 85 °C (A)	
			120 Hz	20 kHz to 40 kHz	120 Hz	20 kHz to 40 kHz
250 WVDC at + 85 °C, SURGE = 300 V						
220.0	82D221M250JB2DE3	0.984 x 1.181 (25.0 x 30.0)	513.0	189.0	1.13	1.94
330.0	82D331M250JD2DE3	0.984 x 1.575 (25.0 x 40.0)	382.0	121.0	1.51	2.79
470.0	82D471M250MB2DE3	1.378 x 1.181 (35.0 x 30.0)	281.0	117.0	1.92	3.07
680.0	82D681M250MD2DE3	1.378 x 1.575 (35.0 x 40.0)	209.0	74.0	2.43	4.26
1000.0	82D102M250ME2DE3	1.378 x 1.969 (35.0 x 50.0)	132.0	58.0	3.32	5.21
400 WVDC at + 85 °C, SURGE = 450 V						
68.0	82D680M400JA2DE3	0.984 x 0.984 (25.0 x 25.0)	3020.0	1720.0	0.44	0.58
100.0	82D101M400JB2DE3	0.984 x 1.181 (25.0 x 30.0)	2060.0	1176.0	0.56	0.74
150.0	82D151M400KB2DE3	1.181 x 1.181 (30.0 x 30.0)	1430.0	820.0	0.76	1.00
220.0	82D221M400KD2DE3	1.181 x 1.575 (30.0 x 40.0)	820.0	470.0	1.10	1.46
330.0	82D331M400MD2DE3	1.378 x 1.575 (35.0 x 40.0)	630.0	360.0	1.39	1.85
450 WVDC at + 85 °C, SURGE = 500 V						
56.0	82D560M450JA2DE3	0.984 x 0.984 (25.0 x 25.0)	3280.0	1730.0	0.42	0.58
100.0	82D101M450JC2DE3	0.984 x 1.378 (25.0 x 35.0)	1730.0	915.0	0.65	0.89
150.0	82D151M450KC2DE3	1.181 x 1.378 (30.0 x 35.0)	1150.0	610.0	0.89	1.22
220.0	82D221M450MC2DE3	1.378 x 1.378 (35.0 x 35.0)	870.0	460.0	1.14	1.56
330.0	82D331M450ME2DE3	1.378 x 1.969 (35.0 x 50.0)	510.0	274.0	1.68	2.29

Note

- Additional Part Numbers in stock include 82D472M050JE2DE3 and 82D681M250MD2DE3. Many other capacitance ratings and voltages are available upon request. Please call for a quotation.

Aluminum Capacitors + 85 °C, Snap-In, General Purpose

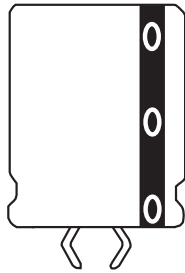


Fig.1 Component Outlines

FEATURES

- Maximum CV
- General purpose design
- Wide voltage range
- Molded cover available in 2 or 3 terminal design with standoffs
- Replaces type 82D


RoHS
COMPLIANT

QUICK REFERENCE DATA	
DESCRIPTION	VALUE
Nominal case size Ø D x L in inches (mm)	1.57 x 3.18 (40.0 x 80.0)
Operating temperature	- 40 °C to + 85 °C
Rated capacitance range, C _R	33 µF to 270 000 µF
Tolerance on C _R	± 20 %
Rated voltage range, U _R	6.3 WVDC to 500 WVDC
Termination	Snap-in
Life validation test at 85 °C	2000 h: ΔCAP ≤ 15 % from initial measurement. ΔESR ≤ 1.5 x initial specified limit. ΔDCL ≤ initial specified limit
Shelf life at 85 °C	500 h: ΔCAP ≤ 15 % from initial measurement. ΔESR ≤ 1.3 x initial specified limit. ΔDCL ≤ 2 x initial specified limit
DC leakage current 5 min charge time	$I = K\sqrt{CV}$ K = 4.0 at + 25 °C I in µA, C in µF, V in Volts

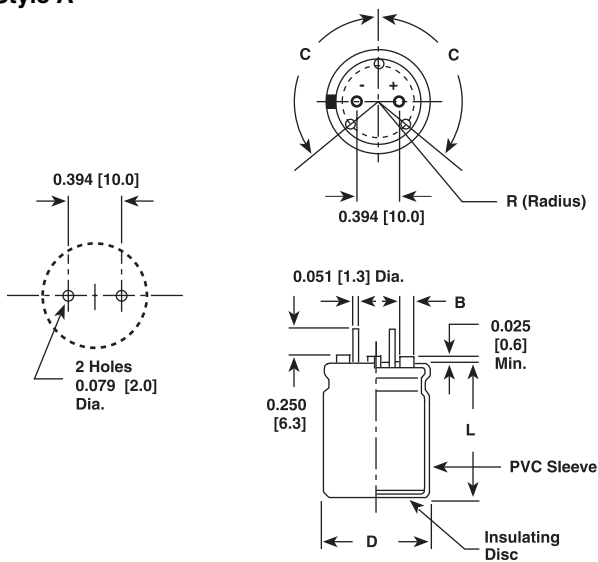
RIPPLE CURRENT MULTIPLIERS			
TEMPERATURE			
AMBIENT TEMPERATURE	MULTIPLIERS		
+ 55 °C	2.0		
+ 65 °C	1.7		
+ 75 °C	1.4		
+ 85 °C	1.0		
FREQUENCY (Hz)			
WVDC	50 TO 60	300 TO 1000	1000 AND UP
16 to 49	0.85	1.10	1.15
50 to 199	0.83	1.15	1.20
200 to 400	0.80	1.30	1.40

DIMENSIONS in inches (millimeters)							
CASE CODE	DIAMETER	LENGTH	STYLE 2 TYPICAL WEIGHT (g)	CASE CODE	DIAMETER	LENGTH	STYLE 2 TYPICAL WEIGHT (g)
	D + 0.04 - 0 (+ 1.0 - 0)	L ± 0.08 (2.0)			D + 0.04 - 0 (+ 1.0 - 0)	L ± 0.08 (2.0)	
JA	1.00 (25.0)	1.00 (25.0)	20.0	MD	1.38 (35.0)	1.57 (40.0)	61.0
JB	1.00 (25.0)	1.18 (30.0)	24.0	ME	1.38 (35.0)	2.00 (50.0)	74.0
JC	1.00 (25.0)	1.38 (35.0)	27.0	MF	1.38 (35.0)	2.50 (63.0)	91.0
JD	1.00 (25.0)	1.57 (40.0)	31.0	MG	1.38 (35.0)	3.18 (80.0)	113.0
JE	1.00 (25.0)	2.00 (50.0)	38.0	NA	1.58 (40.0)	1.00 (25.0)	48.0
KA	1.18 (30.0)	1.00 (25.0)	30.0	NB	1.58 (40.0)	1.18 (30.0)	58.0
KB	1.18 (30.0)	1.18 (30.0)	35.0	NC	1.58 (40.0)	1.38 (35.0)	66.0
KC	1.18 (30.0)	1.38 (35.0)	39.0	ND	1.58 (40.0)	1.57 (40.0)	81.0
KD	1.18 (30.0)	1.57 (40.0)	44.0	NE	1.58 (40.0)	2.00 (50.0)	103.0
KE	1.18 (30.0)	2.00 (50.0)	53.0	NF	1.58 (40.0)	2.50 (63.0)	128.0
MB	1.38 (35.0)	1.18 (30.0)	48.0	NG	1.58 (40.0)	3.18 (80.0)	183.0
MC	1.38 (35.0)	1.38 (35.0)	54.0				

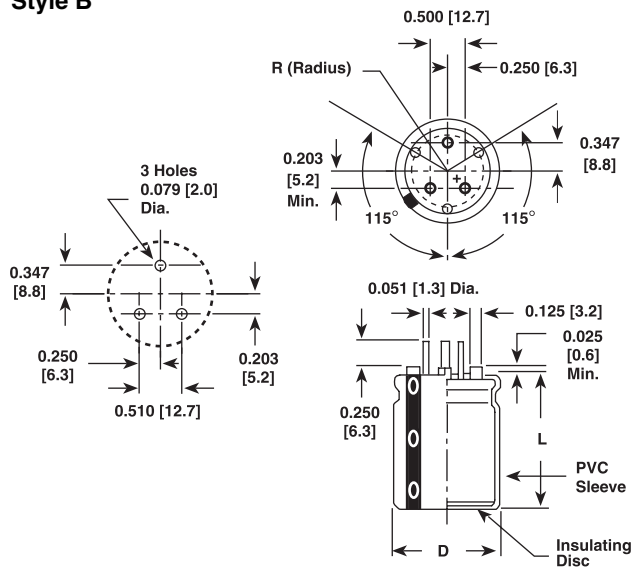
DIMENSIONS in inches (millimeters)					
CIRCUIT BOARD MOUNT TERMINAL DIMENSIONS					
DIAMETER		STYLE A			STYLE B
D	CASE CODE	B	R	C	R
1.00 (25.0)	J	0.093 (2.4)	0.301 (7.6)	140°	N/A
1.18 (30.0)	K	0.125 (3.2)	0.363 (9.2)	120°	0.391 (9.9)
1.38 (35.0)	M	0.125 (3.2)	0.458 (11.6)	120°	0.458 (11.6)

DIMENSIONS AND AVAILABLE FORMS

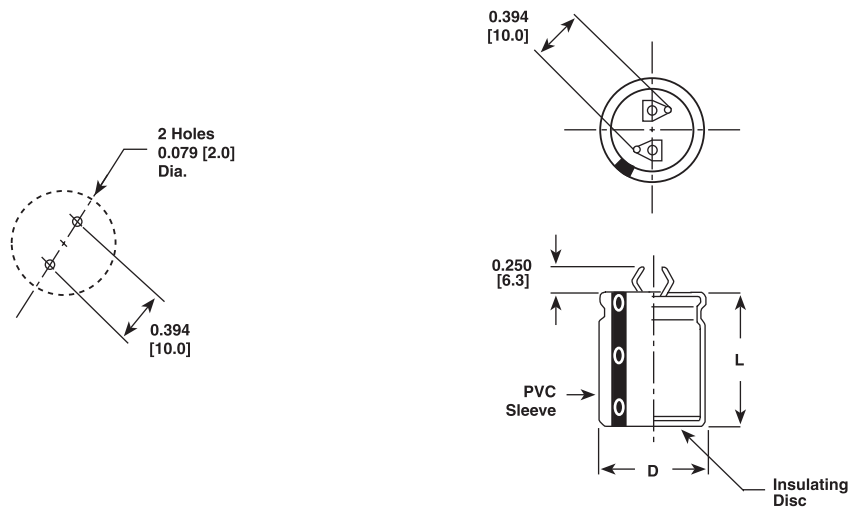
Style A



Style B



Style D





Aluminum Capacitors
+ 85 °C, Snap-In, General Purpose

Vishay Sprague

TERMINAL CONFIGURATION in inches (millimeters)					
LEAD CODE	DESCRIPTION	OUTLINE DRAWINGS		AVAILABLE DIAMETERS	AVAILABLE VOLTAGES AND TYPES
		MOUNTING CONFIGURATION	TERMINAL CONFIGURATION		
D	Standard 2 pin snap-in			0.98 (25.0) - J 1.18 (30.0) - K 1.38 (35.0) - M	All voltages 81D, 81DA 82D, 82DA
A	2 straight wire lead molded cover with standoffs			0.98 (25.0) - J 1.18 (30.0) - K 1.38 (35.0) - M	All voltages 82D, 82DA
					$V \leq 250 V_{DC}$ 81D, 81DA
B	3 straight wire lead molded cover with standoffs			1.18 (30.0) - K 1.38 (35.0) - M	All voltages 82D, 82DA
					$V \leq 250 V_{DC}$ 81D, 81DA

ORDERING EXAMPLE

Electrolytic capacitor 82DA series: 82DA 222 M 050 HA 2 D E3

DESCRIPTION	
CODE	EXPLANATION
82DA	Product type
222	Capacitance value (2200 μ F)
M	Tolerance (M = $\pm 20\%$)
050	Voltage rating at 85 °C (50 V)
HA	Can size (see dimensions table)
2	PVC insulating sleeve
D	Terminal style (D = 2 pin snap-in)
E3	RoHS compliant

ELECTRICAL DATA AND ORDERING INFORMATION							
CAPACITANCE (μ F)	PART NUMBER	NOMINAL CASE SIZE D x L	MAX. ESR at 25 °C (m Ω)		MAX. RIPPLE at + 85 °C (A)		
			120 Hz	20 kHz to 40 kHz	120 Hz	20 kHz to 40 kHz	
16 WVDC at + 85 °C, SURGE = 20 V							
15 000.0	82DA153M016KA2DE3	1.181 x 0.984 (30.0 x 25.0)	67.7	54.0	3.07	3.47	
25 WVDC at + 85 °C, SURGE = 30 V							
6800.0	82DA682M025JA2DE3	0.984 x 0.984 (25.0 x 25.0)	83.8	60.0	2.48	2.93	
10 000.0	82DA103M025KA2DE3	1.181 x 0.984 (30.0 x 25.0)	71.0	54.0	3.00	3.47	
35 WVDC at + 85 °C, SURGE = 40 V							
4700.0	82DA472M035JA2DE3	0.984 x 0.984 (25.0 x 25.0)	89.0	62.0	2.42	2.86	
6800.0	82DA682M035KA2DE3	1.181 x 0.984 (30.0 x 25.0)	75.0	54.0	2.92	3.42	
10 000.0	82DA103M035KB2DE3	1.181 x 1.181 (30.0 x 30.0)	57.0	41.0	3.60	4.20	
50 WVDC at + 85 °C, SURGE = 63 V							
6800.0	82DA682M050JD2DE3	0.984 x 1.575 (25.0 x 40.0)	47.0	31.0	3.91	4.96	
200 WVDC at + 85 °C, SURGE = 250 V							
330.0	82DA331M200JB2DE3	0.984 x 1.181 (25.0 x 30.0)	401.0	191.0	1.28	1.86	
820.0	82DA821M200KD2DE3	1.181 x 1.575 (30.0 x 40.0)	180.0	87.0	2.36	3.41	
1000.0	82DA102M200KE2DE3	1.181 x 1.969 (30.0 x 50.0)	142.0	67.0	2.89	4.22	
1200.0	82DA122M200MD2DE3	1.378 x 1.575 (35.0 x 40.0)	147.0	74.0	2.89	4.06	

Note

- Other ratings and voltages available on special order

Aluminum Capacitors + 105 °C, Snap-In

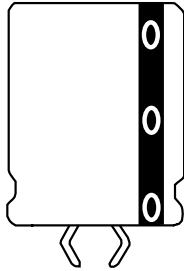


Fig.1 Component Outlines

FEATURES

- Operating temperature to + 105 °C
- High ripple current capability
- Low ESR



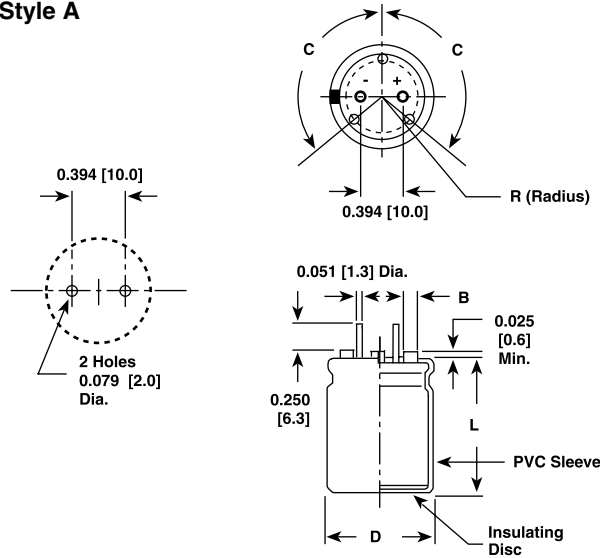
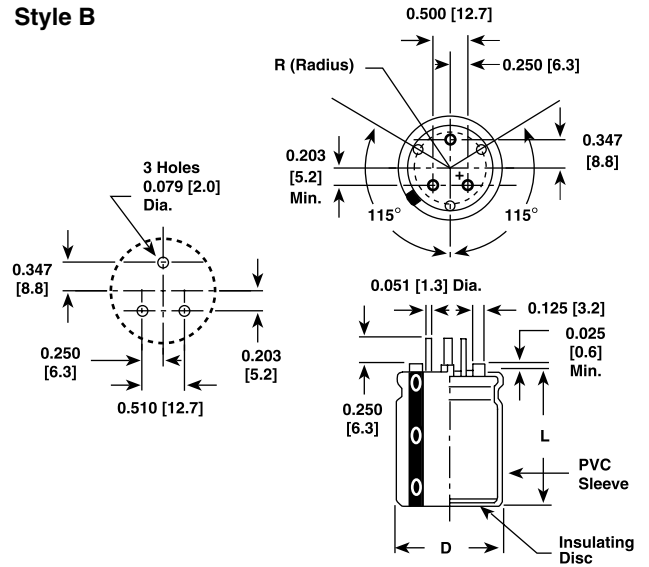
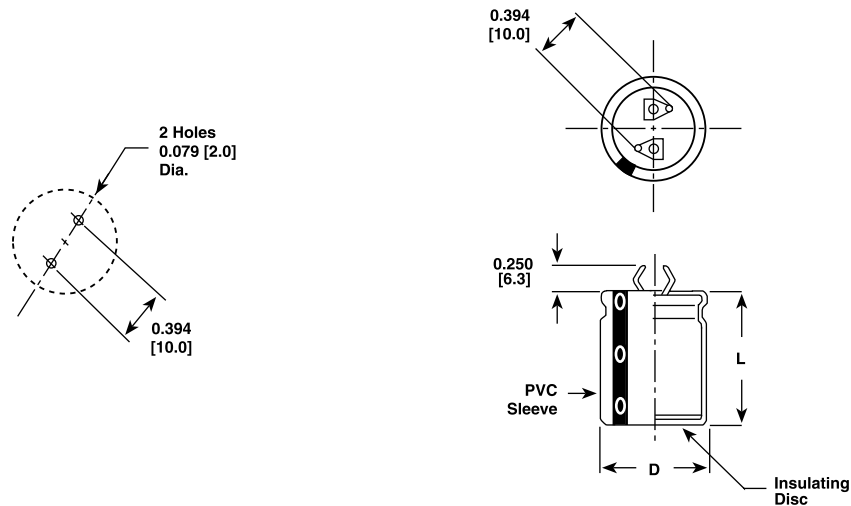
RoHS
COMPLIANT

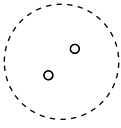
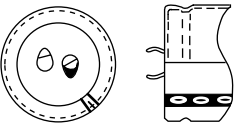
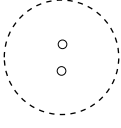
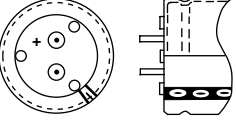
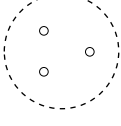
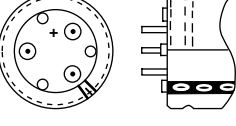
QUICK REFERENCE DATA	
DESCRIPTION	VALUE
Nominal case size Ø D x L in inches (mm)	1.38 x 3.15 (35.0 x 80.0)
Operating temperature	- 40 °C to + 105 °C
Rated capacitance range C _R	68 µF to 47 000 µF
Capacitance tolerance	± 20 %
Voltage rating	16 WVDC to 400 WVDC
Termination	Snap mount
Life validation test at 105 °C	2000 h: ΔCAP ≤ 15 % from initial measurement. ΔESR ≤ 1.3 x initial specified limit. ΔDCL ≤ initial specified limit
Shelf life at 85 °C	500 h: ΔCAP ≤ 15 % from initial measurement. ΔESR ≤ 1.3 x initial specified limit. ΔDCL ≤ 2 x initial specified limit
DC leakage current	$I = K\sqrt{CV}$ K = 4.0 at + 25 °C I in µA, C in µF, V in Volts

RIPPLE CURRENT MULTIPLIERS			
TEMPERATURE			
AMBIENT TEMPERATURE		MULTIPLIERS	
+ 55 °C		1.6	
+ 65 °C		1.4	
+ 75 °C		1.2	
+ 85 °C		1.0	
+ 95 °C		0.70	
+ 105 °C		0.50	
FREQUENCY (Hz)			
WVDC	50 TO 60	300 TO 1000	1000 AND UP
0 to 49	0.85	1.10	1.15
50 to 199	0.83	1.15	1.20
200 to 250	0.80	1.30	1.40
ESL (TYPICAL VALUES AT 1 MHz TO 10 MHz)			
Nominal Diameter	0.98 (25.0)	1.18 (30.0)	1.38 (35.0)
Typical ESL (nH)	8.0	10.0	12.0

DIMENSIONS in inches (millimeters)									
CASE CODE	DIAMETER		LENGTH		CASE CODE	DIAMETER		LENGTH	
	D + 0.04 - 0 (+ 1.0 - 0)		L ± 0.08 (2.0)			D + 0.04 - 0 (+ 1.0 - 0)		L ± 0.08 (2.0)	
JA	1.00 (25.0)		1.00 (25.0)		KD	1.18 (30.0)		1.57 (40.0)	
JB	1.00 (25.0)		1.18 (30.0)		KE	1.18 (30.0)		2.00 (50.0)	
JC	1.00 (25.0)		1.38 (35.0)		MB	1.38 (35.0)		1.18 (30.0)	
JD	1.00 (25.0)		1.57 (40.0)		MC	1.38 (35.0)		1.38 (35.0)	
JE	1.00 (25.0)		2.00 (50.0)		MD	1.38 (35.0)		1.57 (40.0)	
KA	1.18 (30.0)		1.00 (25.0)		ME	1.38 (35.0)		2.00 (50.0)	
KB	1.18 (30.0)		1.18 (30.0)		MF	1.38 (35.0)		2.50 (63.0)	
KC	1.18 (30.0)		1.38 (35.0)		MG	1.38 (35.0)		3.18 (80.0)	

DIMENSIONS in inches (millimeters)					
CIRCUIT BOARD MOUNT TERMINAL DIMENSIONS					
DIAMETER		STYLE A			STYLE B
D	CASE CODE	B	R	C	R
1.00 (25.0)	J	0.093 (2.4)	0.301 (7.6)	140°	N/A
1.18 (30.0)	K	0.125 (3.2)	0.363 (9.2)	120°	0.391 (9.9)
1.38 (35.0)	M	0.125 (3.2)	0.458 (11.6)	120°	0.458 (11.6)

DIMENSIONS AND AVAILABLE FORMS
Style A

Style B

Style D


TERMINAL CONFIGURATION in inches (millimeters)					
LEAD CODE	DESCRIPTION	OUTLINE DRAWINGS		AVAILABLE DIAMETERS	AVAILABLE VOLTAGES AND TYPES
		MOUNTING CONFIGURATION	TERMINAL CONFIGURATION		
D	Standard 2 pin snap-in			0.98 (25.0) - J 1.18 (30.0) - K 1.38 (35.0) - M	All voltages 81D, 81DA 82D, 82DA
A	2 straight wire lead molded cover with standoffs			0.98 (25.0) - J 1.18 (30.0) - K 1.38 (35.0) - M	All voltages 82D, 82DA $V \leq 250 V_{DC}$ 81D, 81DA
B	3 straight wire lead molded cover with standoffs			1.18 (30.0) - K 1.38 (35.0) - M	All voltages 82D, 82DA $V \leq 250 V_{DC}$ 81D, 81DA

ORDERING EXAMPLE

Electrolytic capacitor 81D series:

81D 221 M 250 HD 2 D E3

DESCRIPTION	
CODE	EXPLANATION
81D	Product type
221	Capacitance value (220 μ F)
M	Tolerance (M = ± 20 %)
250	Voltage rating at 105 °C (250 V)
HD	Can size (see dimensions table)
2	PVC insulating sleeve
D	Terminal style (D = 2 pin snap-in)
E3	RoHS compliant

ELECTRICAL DATA AND ORDERING INFORMATION						
CAPACITANCE (μ F)	PART NUMBER	NOMINAL CASE SIZE D x L	MAX. ESR at 25 °C (m Ω)		MAX. RIPPLE at + 85 °C (A)	
			120 Hz	20 kHz to 40 kHz	120 Hz	20 kHz to 40 kHz
16 WVDC at + 105 °C, SURGE = 20 V						
15 000.0	81D153M016JC2DE3	0.984 x 1.378 (25.0 x 35.0)	58.0	43.0	4.72	5.47
22 000.0	81D223M016KB2DE3	1.181 x 1.181 (30.0 x 30.0)	53.7	41.0	5.24	5.94
33 000.0	81D333M016MC2DE3	1.378 x 1.378 (35.0 x 35.0)	28.0	21.0	8.42	9.71
47 000.0	81D473M016MD2DE3	1.378 x 1.575 (35.0 x 40.0)	23.0	17.0	9.70	11.20
25 WVDC at + 105 °C, SURGE = 30 V						
4700.0	81D472M025JA2DE3	0.984 x 0.984 (25.0 x 25.0)	86.0	60.0	3.44	4.15
6800.0	81D682M025KA2DE3	1.181 x 0.984 (30.0 x 25.0)	71.0	54.0	4.25	4.91
10 000.0	81D103M025KB2DE3	1.181 x 1.181 (30.0 x 30.0)	54.0	41.0	5.24	5.94
15 000.0	81D153M025KD2DE3	1.181 x 1.575 (30.0 x 40.0)	36.4	27.0	7.07	8.16
22 000.0	81D223M025MD2DE3	1.378 x 1.575 (35.0 x 40.0)	23.0	17.0	9.41	11.20

Aluminum Capacitors
+ 105 °C, Snap-In

Vishay Sprague

ELECTRICAL DATA AND ORDERING INFORMATION						
CAPACITANCE (μ F)	PART NUMBER	NOMINAL CASE SIZE D x L	MAX. ESR at 25 °C (m Ω)		MAX. RIPPLE at + 85 °C (A)	
			120 Hz	20 kHz to 40 kHz	120 Hz	20 kHz to 40 kHz
35 WVDC at + 105 °C, SURGE = 40 V						
4700.0	81D472M035KA2DE3	1.181 x 0.984 (30.0 x 25.0)	75.0	54.0	4.13	4.84
6800.0	81D682M035KB2DE3	1.181 x 1.181 (30.0 x 30.0)	57.0	41.0	5.10	5.94
12 000.0	81D123M035KD2DE3	1.181 x 1.575 (30.0 x 40.0)	37.7	27.0	6.92	8.16
10 000.0	81D103M035MB2DE3	1.378 x 1.181 (35.0 x 30.0)	36.0	24.0	7.04	8.63
50 WVDC at + 105 °C, SURGE = 63 V						
2200.0	81D222M050JB2DE3	0.984 x 1.181 (25.0 x 30.0)	85.0	48.0	3.69	4.93
4700.0	81D472M050KC2DE3	1.181 x 1.378 (30.0 x 35.0)	53.0	33.0	5.51	7.05
6800.0	81D682M050KE2DE3	1.181 x 1.969 (30.0 x 50.0)	33.0	22.0	8.04	9.74
63 WVDC at + 105 °C, SURGE = 79 V						
2200.0	81D222M063JC2DE3	0.984 x 1.378 (25.0 x 35.0)	72.0	38.0	4.21	5.78
4700.0	81D472M063KD2DE3	1.181 x 1.575 (30.0 x 40.0)	44.0	27.0	6.32	8.16
100 WVDC at + 105 °C, SURGE = 125 V						
680.0	81D681M100JB2DE3	0.984 x 1.181 (25.0 x 30.0)	188.0	86.0	2.48	3.67
1000.0	81D102M100KB2DE3	1.181 x 1.181 (30.0 x 30.0)	136.0	66.0	3.28	4.69
1500.0	81D152M100KC2DE3	1.181 x 1.378 (30.0 x 35.0)	106.0	52.0	3.90	5.59
2200.0	81D222M100KE2DE3	1.181 x 1.969 (30.0 x 50.0)	66.0	33.0	5.69	8.05
200 WVDC at + 105 °C, SURGE = 250 V						
220.0	81D221M200JA2DE3	0.984 x 0.984 (25.0 x 25.0)	625.0	272.0	1.37	2.08
330.0	81D331M200KA2DE3	1.181 x 0.984 (30.0 x 25.0)	498.0	192.0	1.71	2.77
470.0	81D471M200KB2DE3	1.181 x 1.181 (30.0 x 30.0)	294.0	136.0	2.39	3.51
1000.0	81D102M200KE2DE3	1.181 x 1.969 (30.0 x 50.0)	142.0	67.0	4.09	5.95
820.0	81D821M200MC2DE3	1.378 x 1.378 (35.0 x 35.0)	189.0	93.0	3.47	4.94
1000.0	81D102M200MD2DE3	1.378 x 1.575 (35.0 x 40.0)	149.0	74.0	4.07	5.78
250 WVDC at + 105 °C, SURGE = 300 V						
330.0	81D331M250JD2DE3	0.984 x 1.575 (25.0 x 40.0)	382.0	121.0	2.12	3.81
470.0	81D471M250JE2DE3	0.984 x 1.969 (25.0 x 25.0)	243.0	93.0	2.81	4.54
680.0	81D681M250KE2DE3	1.181 x 1.969 (30.0 x 50.0)	198.0	67.0	3.47	5.99
1000.0	81D102M250ME2DE3	1.378 x 1.969 (35.0 x 50.0)	132.0	58.0	4.69	7.07
400 WVDC at + 105 °C, SURGE = 450 V						
100.0	81D101M400JB2DE3	0.984 x 1.181 (25.0 x 30.0)	2920.0	1550.0	0.683	0.902
150.0	81D151M400JD2DE3	0.984 x 1.575 (25.0 x 40.0)	1650.0	880.0	1.000	1.1329
220.0	81D221M400KD2DE3	1.181 x 1.575 (30.0 x 40.0)	1110.0	580.0	1.476	1.781
330.0	81D331M400MD2DE3	1.378 x 1.575 (35.0 x 40.0)	730.0	390.0	1.695	2.257

Aluminum Capacitors + 105 °C, Snap-In

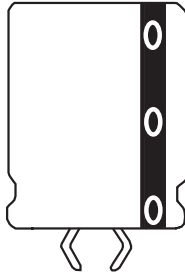


Fig.1 Component Outlines

FEATURES

- Improved performance
- Operating temperature to + 105 °C
- High ripple current capability
- Low ESR
- Replaces type 81D



RoHS
COMPLIANT

QUICK REFERENCE DATA	
DESCRIPTION	VALUE
Noal case size Ø D x L in inches (mm)	1.38 x 3.18 (35.0 x 80.0)
Operating temperature	- 40 °C to + 105 °C
Rated capacitance range, C _R	47 µF to 180 000 µF
Tolerance on C _R	± 20 %
Rated voltage range, U _R	6.3 WVDC to 400 WVDC
Termination	Snap-in
Life validation test at 105 °C	2000 h: ΔCAP ≤ 15 % from initial measurement. ΔESR ≤ 1.5 x initial specified limit. ΔDCL ≤ initial specified limit
Shelf life at 85 °C	500 h: ΔCAP ≤ 15 % from initial measurement. ΔESR ≤ 1.3 x initial specified limit. ΔDCL ≤ 2 x initial specified limit
DC leakage current 5 min charge time	$I = K \cdot \sqrt{CV}$ K = 4.0 at + 25 °C I in µA, C in µF, V in Volts

RIPPLE CURRENT MULTIPLIERS			
TEMPERATURE			
AMBIENT TEMPERATURE		MULTIPLIERS	
+ 55 °C		1.5	
+ 65 °C		1.34	
+ 75 °C		1.2	
+ 85 °C		1.0	
+ 95 °C		0.77	
+ 105 °C		0.45	
FREQUENCY (Hz)			
WVDC	50 TO 60	300 TO 1000	1000 AND UP
0 to 49	0.85	1.10	1.15
50 to 199	0.83	1.15	1.20
200 to 400	0.80	1.30	1.40

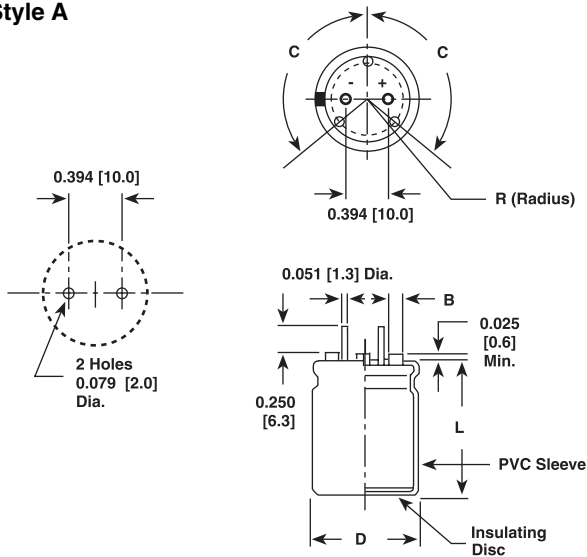
DIMENSIONS in inches (millimeters)							
CASE CODE	DIAMETER		STYLE 2 TYPICAL WEIGHT (g)	CASE CODE	DIAMETER		STYLE 2 TYPICAL WEIGHT (g)
	D + 0.04 - 0 (+ 1.0 - 0)	L ± 0.08 (2.0)			D + 0.04 - 0 (+ 1.0 - 0)	L ± 0.08 (2.0)	
JA	1.00 (25.0)	1.00 (25.0)	20.0	MD	1.38 (35.0)	1.57 (40.0)	61.0
JB	1.00 (25.0)	1.18 (30.0)	24.0	ME	1.38 (35.0)	2.00 (50.0)	74.0
JC	1.00 (25.0)	1.38 (35.0)	27.0	MF	1.38 (35.0)	2.50 (63.0)	91.0
JD	1.00 (25.0)	1.57 (40.0)	31.0	MG	1.38 (35.0)	3.18 (80.0)	113.0
JE	1.00 (25.0)	2.00 (50.0)	38.0	NA	1.58 (40.0)	1.00 (25.0)	48.0
KA	1.18 (30.0)	1.00 (25.0)	30.0	NB	1.58 (40.0)	1.18 (30.0)	58.0
KB	1.18 (30.0)	1.18 (30.0)	35.0	NC	1.58 (40.0)	1.38 (35.0)	66.0
KC	1.18 (30.0)	1.38 (35.0)	39.0	ND	1.58 (40.0)	1.57 (40.0)	81.0
KD	1.18 (30.0)	1.57 (40.0)	44.0	NE	1.58 (40.0)	2.00 (50.0)	103.0
KE	1.18 (30.0)	2.00 (50.0)	53.0	NF	1.58 (40.0)	2.50 (63.0)	128.0
MB	1.38 (35.0)	1.18 (30.0)	48.0	NG	1.58 (40.0)	3.18 (80.0)	183.0
MC	1.38 (35.0)	1.38 (35.0)	54.0				



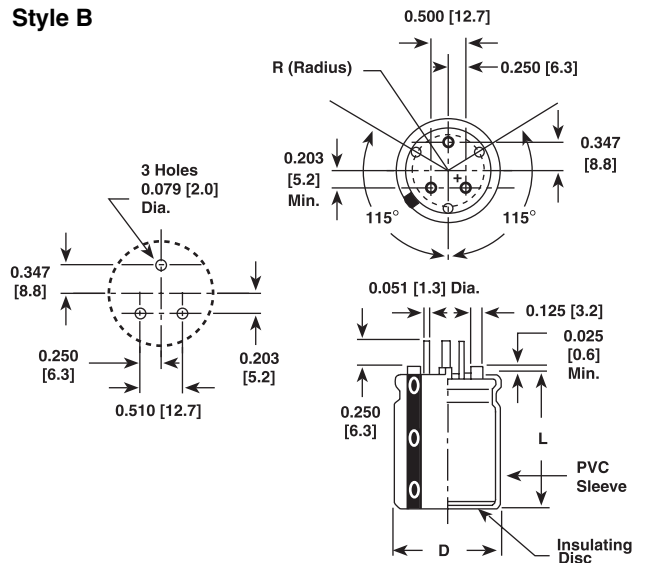
DIMENSIONS in inches (millimeters)					
CIRCUIT BOARD MOUNT TERMINAL DIMENSIONS					
DIAMETER		STYLE A			STYLE B
D	CASE CODE	B	R	C	R
1.00 (25.0)	J	0.093 (2.4)	0.301 (7.6)	140°	N/A
1.18 (30.0)	K	0.125 (3.2)	0.363 (9.2)	120°	0.391 (9.9)
1.38 (35.0)	M	0.125 (3.2)	0.458 (11.6)	120°	0.458 (11.6)

DIMENSIONS AND AVAILABLE FORMS

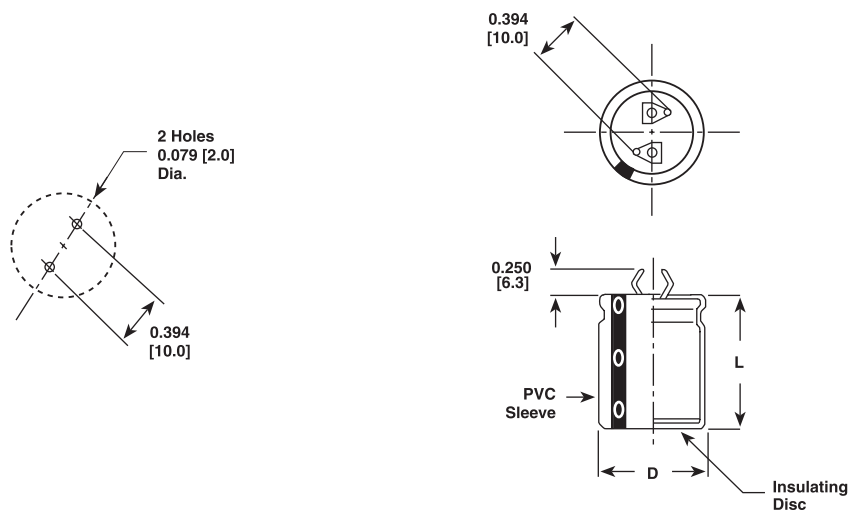
Style A

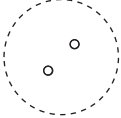
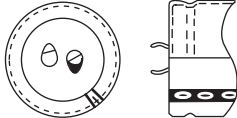
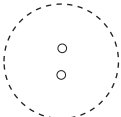
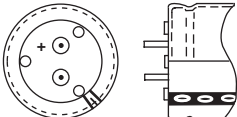
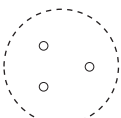
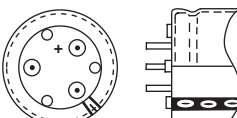


Style B



Style D



TERMINAL CONFIGURATION in inches (millimeters)					
LEAD CODE	DESCRIPTION	OUTLINE DRAWINGS		AVAILABLE DIAMETERS	AVAILABLE VOLTAGES AND TYPES
		MOUNTING CONFIGURATION	TERMINAL CONFIGURATION		
D	Standard 2 pin snap-in			0.98 (25.0) - J 1.18 (30.0) - K 1.38 (35.0) - M	All voltages 81D, 81DA 82D, 82DA
A	2 straight wire lead molded cover with standoffs			0.98 (25.0) - J 1.18 (30.0) - K 1.38 (35.0) - M	All voltages 82D, 82DA V ≤ 250 V _{DC} 81D, 81DA
B	3 straight wire lead molded cover with standoffs			1.18 (30.0) - K 1.38 (35.0) - M	All voltages 82D, 82DA V ≤ 250 V _{DC} 81D, 81DA

ORDERING EXAMPLE

Electrolytic capacitor 81DA series: 81DA 271 M 250 HD 2 D E3

DESCRIPTION	
CODE	EXPLANATION
81DA	Product type
271	Capacitance value (270 μF)
M	Tolerance (M = ± 20 %)
250	Voltage rating at 105 °C (250 V)
HD	Can size (see dimensions table)
2	PVC insulating sleeve
D	Terminal style (D = 2 pin snap-in)
E3	RoHS compliant

ELECTRICAL DATA AND ORDERING INFORMATION						
CAPACITANCE (μF)	PART NUMBER	NOMINAL CASE SIZE D x L	MAX. ESR at 25 °C (mΩ)		MAX. RIPPLE at + 85 °C (A)	
			120 Hz	20 kHz to 40 kHz	120 Hz	20 kHz to 40 kHz
25 WVDC at + 105 °C, SURGE = 30 V						
10 000.0	81DA103M025JC2DE3	0.984 x 1.378 (25.0 x 35.0)	48.9	37.2	5.16	6.64
15 000.0	81DA153M025KC2DE3	1.181 x 1.378 (30.0 x 35.0)	42.2	33.0	6.17	7.30
35 WVDC at + 105 °C, SURGE = 40 V						
4700.0	81DA472M035JA2DE3	0.984 x 0.984 (25.0 x 25.0)	83.3	60.3	3.53	4.76
10 000.0	81DA103M035KB2DE3	1.181 x 1.181 (30.0 x 30.0)	53.4	41.0	5.19	5.94
50 WVDC at + 105 °C, SURGE = 63 V						
6800.0	81DA682M050KC2DE3	1.181 x 1.378 (30.0 x 50.0)	47.5	33.0	5.82	7.05
200 WVDC at + 105 °C, SURGE = 250 V						
330.0	81DA331M200JB2DE3	0.984 x 1.181 (25.0 x 30.0)	399.3	184.4	1.81	2.67
820.0	81DA821M200KD2DE3	1.181 x 1.575 (30.0 x 40.0)	175.4	85.5	3.37	4.84
250 WVDC at + 105 °C, SURGE = 300 V						
560.0	81DA561M250MB2DE3	1.378 x 1.181 (35.0 x 30.0)	254.0	113.0	2.82	4.23

Note

- Other ratings and voltages available on special order

Aluminum Capacitors + 85 °C, Large Can

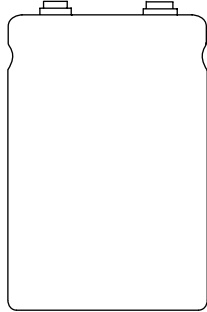


Fig. 1 Component Outlines

FEATURES

- The industry standard for large can aluminum capacitors
- Ideal for high wattage power supplies and energy storage applications
- Capacitance values to 2.2 F
- Largest CV available
- Highest voltage available


**RoHS
COMPLIANT**

QUICK REFERENCE DATA	
DESCRIPTION	VALUE
Nominal case size Ø D x L in inches (mm)	1.375 x 1.625 (35.0 x 41.3) to 3.00 x 8.675 (76.2 x 220.3)
Operating temperature	- 40 °C to + 85 °C
Rated capacitance range, C _R	100 µF to 2.2 F
Tolerance on C _R	- 10 % to 50 %
Rated voltage range, U _R	6.3 WVDC to 450 WVDC
Termination	Screw thread
Life validation test at 85 °C	2000 h: ΔCAP ≤ 15 % from initial measurement ΔESR ≤ 1.5 x initial specified limit ΔDCL ≤ initial specified limit
Shelf life at 85 °C	500 h: ΔCAP ≤ 15 % from initial measurement. ΔESR ≤ 1.2 x initial specified limit. ΔDCL ≤ 2 x initial specified limit
DC leakage current	$I = K \sqrt{CV}$ K = 4.0 at + 25 °C; 32.0 at + 85 °C I in µA, C in µF, V in Volts

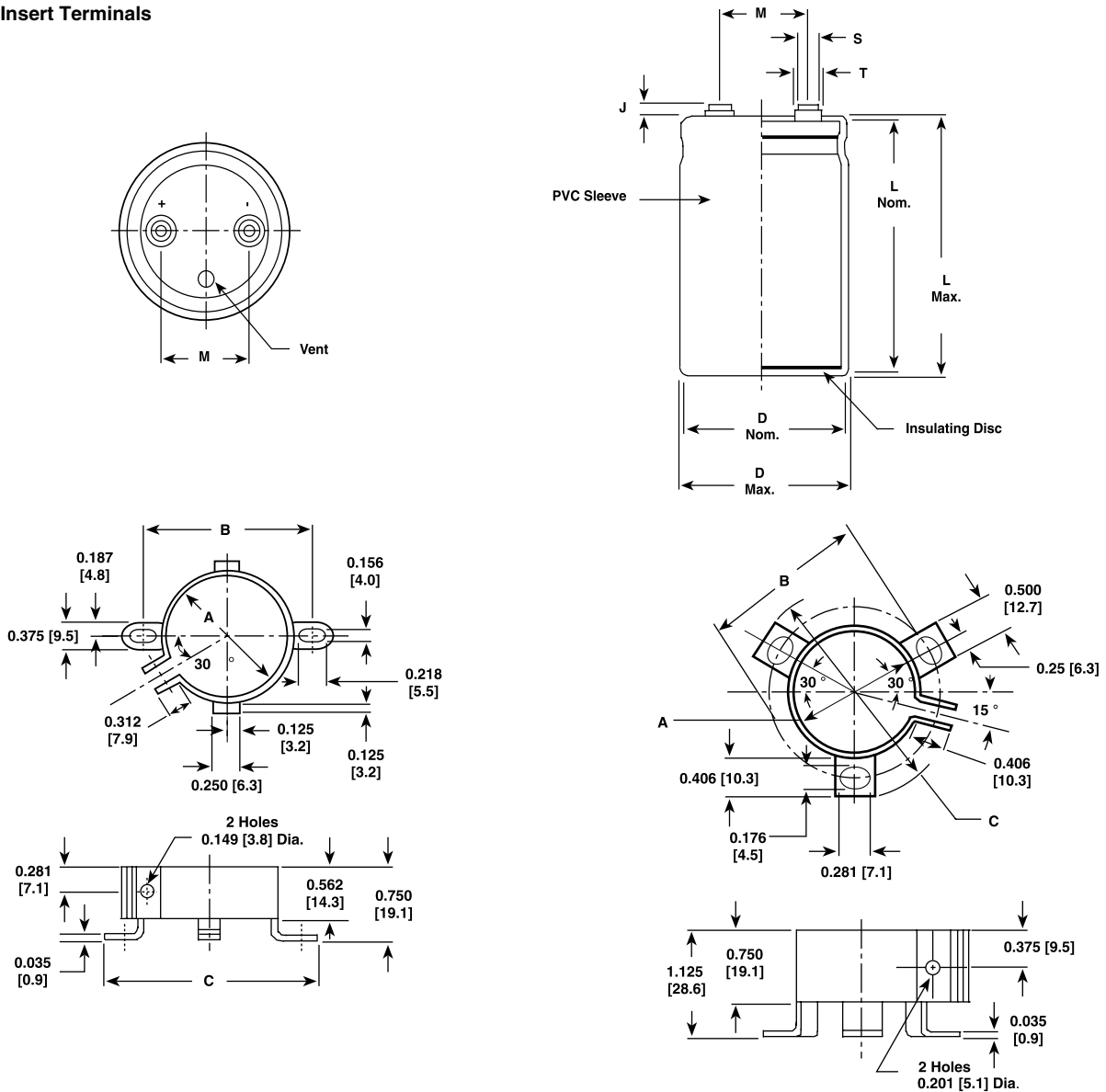
RIPPLE CURRENT MULTIPLIERS			
TEMPERATURE			
AMBIENT TEMPERATURE		MULTIPLIERS	
+ 85 °C		1.0	
+ 75 °C		1.4	
+ 65 °C		1.7	
+ 55 °C and below		2.0	
FREQUENCY (Hz)			
RATED WVDC	120	400	1000 AND UP
0 to 50	1.0	1.05	1.10
51 to 100	1.0	1.10	1.15
150 to 300	1.0	1.15	1.25
301 to 450	1.0	1.20	1.30

DIMENSIONS in inches (millimeters)

LARGE CAN CAPACITORS							
CASE CODE	NOMINAL		WITH INSULATING SLEEVE			TERMINAL SPACING M ± 0.016 (0.4)	TYPICAL WEIGHT (g)
	D ± 0.032 (0.8)	L ± 0.063 (1.6)	D (Max.)	L (Max.)	P TERMINAL H (Max.)		
AN	1.375 (35.0)	1.625 (41.0)	1.453 (36.9)	1.750 (44.5)	1.849 (47.0)	0.500 (12.7)	43.0
AY	1.375 (35.0)	1.875 (48.0)	1.453 (36.9)	2.000 (50.8)	1.099 (53.3)	0.500 (12.7)	54.0
AA	1.375 (35.0)	2.125 (54.0)	1.453 (36.9)	2.250 (57.2)	1.349 (59.7)	0.500 (12.7)	63.0
AM	1.375 (35.0)	2.625 (67.0)	1.453 (36.9)	2.750 (69.9)	1.849 (72.4)	0.500 (12.7)	82.0
AB	1.375 (35.0)	3.125 (79.0)	1.453 (36.9)	3.250 (82.6)	1.349 (85.1)	0.500 (12.7)	105.0
AL	1.375 (35.0)	3.625 (92.0)	1.453 (36.9)	3.750 (95.3)	1.849 (97.8)	0.500 (12.7)	122.0
AC	1.375 (35.0)	4.125 (105.0)	1.453 (36.9)	4.250 (108.0)	1.349 (110.5)	0.500 (12.7)	129.0
AD	1.375 (35.0)	4.625 (117.0)	1.453 (36.9)	4.750 (120.7)	1.849 (123.2)	0.500 (12.7)	162.0
AE	1.375 (35.0)	5.125 (130.0)	1.453 (36.9)	5.250 (133.4)	1.349 (125.9)	0.500 (12.7)	179.0
AF	1.375 (35.0)	5.625 (143.0)	1.453 (36.9)	5.750 (146.1)	1.849 (148.6)	0.500 (12.7)	201.0

DIMENSIONS in inches (millimeters)							
LARGE CAN CAPACITORS							
CASE CODE	NOMINAL		WITH INSULATING SLEEVE			TERMINAL SPACING M ± 0.016 (0.4)	TYPICAL WEIGHT (g)
	D ± 0.032 (0.8)	L ± 0.063 (1.6)	D (Max.)	L (Max.)	P TERMINAL H (Max.)		
EN	1.750 (44.0)	1.625 (41.0)	1.828 (46.4)	1.750 (44.5)	1.849 (47.0)	0.750 (19.1)	71.0
EY	1.750 (44.0)	1.875 (48.0)	1.828 (46.4)	2.000 (50.8)	2.099 (53.3)	0.750 (19.1)	88.0
EA	1.750 (44.0)	2.125 (54.0)	1.828 (46.4)	2.250 (57.2)	2.349 (59.7)	0.750 (19.1)	102.0
EM	1.750 (44.0)	2.625 (67.0)	1.828 (46.4)	2.750 (69.9)	2.849 (72.4)	0.750 (19.1)	133.0
EB	1.750 (44.0)	3.125 (79.0)	1.828 (46.4)	3.250 (82.6)	3.349 (85.1)	0.750 (19.1)	167.0
EL	1.750 (44.0)	3.625 (92.0)	1.828 (46.4)	3.750 (95.3)	3.849 (97.8)	0.750 (19.1)	198.0
EC	1.750 (44.0)	4.125 (105.0)	1.828 (46.4)	4.250 (108.0)	4.349 (110.5)	0.750 (19.1)	230.0
ED	1.750 (44.0)	4.625 (117.0)	1.828 (46.4)	4.750 (120.7)	4.849 (123.2)	0.750 (19.1)	252.0
EE	1.750 (44.0)	5.125 (130.0)	1.828 (46.4)	5.250 (133.4)	5.349 (135.9)	0.750 (19.1)	269.0
EF	1.750 (44.0)	5.625 (143.0)	1.828 (46.4)	5.750 (146.1)	5.849 (148.6)	0.750 (19.1)	318.0
BY	2.000 (51.0)	1.875 (48.0)	2.078 (52.8)	2.000 (50.8)	2.099 (53.3)	0.875 (22.2)	113.0
BA	2.000 (51.0)	2.125 (54.0)	2.078 (52.8)	2.250 (57.2)	2.349 (59.7)	0.875 (22.2)	133.0
BM	2.000 (51.0)	2.625 (67.0)	2.078 (52.8)	2.750 (69.9)	2.849 (72.4)	0.875 (22.2)	176.0
BB	2.000 (51.0)	3.125 (79.0)	2.078 (52.8)	3.250 (82.6)	3.349 (85.1)	0.875 (22.2)	213.0
BL	2.000 (51.0)	3.625 (92.0)	2.078 (52.8)	3.750 (95.3)	3.849 (97.8)	0.875 (22.2)	261.0
BC	2.000 (51.0)	4.125 (105.0)	2.078 (52.8)	4.250 (108.0)	4.349 (110.5)	0.875 (22.2)	381.0
BD	2.000 (51.0)	4.625 (117.0)	2.078 (52.8)	4.750 (120.7)	4.849 (123.2)	0.875 (22.2)	326.0
BE	2.000 (51.0)	5.125 (130.0)	2.078 (52.8)	5.250 (133.4)	5.349 (135.9)	0.875 (22.2)	337.0
BF	2.000 (51.0)	5.625 (143.0)	2.078 (52.8)	5.750 (146.1)	5.849 (148.6)	0.875 (22.2)	408.0
CB	2.500 (64.0)	3.125 (79.0)	2.578 (65.5)	3.250 (82.6)	N/A	1.125 (28.6)	329.0
CL	2.500 (64.0)	3.625 (92.0)	2.578 (65.5)	3.750 (95.3)	N/A	1.125 (28.6)	400.0
CC	2.500 (64.0)	4.125 (105.0)	2.578 (65.5)	4.250 (108.0)	N/A	1.125 (28.6)	473.0
CD	2.500 (64.0)	4.625 (117.0)	2.578 (65.5)	4.750 (120.7)	N/A	1.125 (28.6)	562.0
CE	2.500 (64.0)	5.125 (130.0)	2.578 (65.5)	5.250 (133.4)	N/A	1.125 (28.6)	607.0
CF	2.500 (64.0)	5.625 (143.0)	2.578 (65.5)	5.750 (146.1)	N/A	1.125 (28.6)	675.0
DB	3.000 (76.0)	3.125 (79.0)	3.078 (78.2)	3.250 (82.6)	N/A	1.250 (31.8)	496.0
DL	3.000 (76.0)	3.625 (92.0)	3.078 (78.2)	3.750 (95.3)	N/A	1.250 (31.8)	598.0
DC	3.000 (76.0)	4.125 (105.0)	3.078 (78.2)	4.250 (108.0)	N/A	1.250 (31.8)	700.0
DD	3.000 (76.0)	4.625 (117.0)	3.078 (78.2)	4.750 (120.7)	N/A	1.250 (31.8)	802.0
DE	3.000 (76.0)	5.125 (130.0)	3.078 (78.2)	5.250 (133.4)	N/A	1.250 (31.8)	944.0
DF	3.000 (76.0)	5.625 (143.0)	3.078 (78.2)	5.750 (146.1)	N/A	1.250 (31.8)	1004.0
DJ	3.000 (76.0)	8.625 (219.0)	3.078 (78.2)	8.750 (222.3)	N/A	1.250 (31.8)	1403.0

DIMENSIONS in inches (millimeters)						
BRACKETS (RoHS COMPLIANT)						
TYPE	PART NUMBER	A	B	C	FIGURE NUMBER	
2 Feet	1245860035A	1.375 (34.9)	1.781 (45.2)	2.218 (56.3)	1	
3 Feet	1245860036A	2.000 (50.8)	2.500 (63.5)	2.875 (73.0)	2	
3 Feet	1245860037A	2.500 (63.5)	3.000 (76.2)	3.375 (85.7)	2	
3 Feet	1245860038A	3.000 (76.2)	3.500 (88.9)	3.875 (98.4)	2	
SCREW INSERT TERMINAL DIMENSIONS						
TERMINAL CODE	THREAD	THREAD DEPTH	HEIGHT J ± 0.032 (0.8)	DIAMETER S ± 0.010 (0.25)	DIAMETER T ± 0.010 (0.25)	NOTES
A	10-32 NF-28	0.219 (5.6)	0.063 (1.6)	0.313 (8.0)	0.438 (11.1)	All cases codes
B	10-32 NF-28	0.375 (9.5)	0.250 (6.4)	0.313 (8.0)	0.438 (11.1)	All cases codes
D	1/4-28 NF-28	0.344 (8.7)	0.093 (2.4)	0.688 (17.5)	-	C and D dia. codes only

DIMENSIONS AND AVAILABLE FORMS
Screw Insert Terminals

ORDERING EXAMPLE

Electrolytic capacitor 36DY series: 36DY 683 F 6R3 AA 2 A

DESCRIPTION	
CODE	EXPLANATION
36DY	Product type
683	Capacitance value (68 000 μ F)
F	Tolerance (G = - 10 %/+ 75 %; F = - 10 %/+ 50 %)
6R3	Voltage rating at 85 °C (6.3 V)
AA	Can size (see dimensions table)
2	PVC insulating sleeve
A	Terminal code (low insert 10-32 screw thread)

ELECTRICAL DATA AND ORDERING INFORMATION

CAPACITANCE (μ F)	PART NUMBER	NOMINAL CASE SIZE D x L	MAX. ESR at 25 °C (m Ω) 120 Hz	MAX. RIPPLE at + 85 °C (A) 120 Hz
6.3 WVDC at + 85 °C, SURGE = 8 V				
68 000.0	36DY683F6R3AA2A	1.375 x 2.125 (35.0 x 54.0)	32.0	5.92
120 000.0	36DY124F6R3AB2A	1.375 x 3.125 (35.0 x 79.0)	20.0	8.70
220 000.0	36DY224F6R3BB2A	2.000 x 3.125 (51.0 x 79.0)	11.2	14.4
560 000.0	36DY564F6R3BF2A	2.000 x 5.625 (51.0 x 143.0)	6.6	23.8
820 000.0	36DY824F6R3CF2A	2.500 x 5.625 (64.0 x 143.0)	4.1	34.4
1.0 F	36DY105F6R3DD2A	3.000 x 4.625 (76.0 x 117.0)	14.5	34.0
10 WVDC at + 85 °C, SURGE = 12 V				
82 000.0	36DY823F010AB2A	1.375 x 3.125 (35.0 x 79.0)	19.8	8.65
150 000.0	36DY154F010AD2A	1.375 x 4.625 (35.0 x 117.0)	14.0	12.2
220 000.0	36DY224F010BL2A	2.000 x 3.625 (51.0 x 92.0)	9.6	16.5
390 000.0	36DY394F010BF2A	2.000 x 5.625 (51.0 x 143.0)	6.7	23.7
470 000.0	36DY474F010CC2A	2.500 x 4.125 (64.0 x 105.0)	5.0	27.6
680 000.0	36DY684F010DC2A	3.000 x 4.125 (76.0 x 105.0)	5.0	30.9
15 WVDC at + 85 °C, SURGE = 18 V				
47 000.0	36DY473F015AM2A	1.375 x 2.625 (35.0 x 67.0)	25.0	7.19
68 000.0	36DY683F015AL2A	1.375 x 3.625 (35.0 x 92.0)	17.5	9.79
100 000.0	36DY104F015AD2A	1.375 x 4.625 (35.0 x 117.0)	14.2	12.1
56 000.0	36DY563F015BA2A	2.000 x 2.125 (51.0 x 54.0)	20.0	9.40
100 000.0	36DY104F015BB2A	2.000 x 3.125 (51.0 x 79.0)	11.6	14.2
150 000.0	36DY154F015BC2A	2.000 x 4.125 (51.0 x 105.0)	8.7	18.3
220 000.0	36DY224F015BF2A	2.000 x 5.625 (51.0 x 143.0)	6.7	23.6
470 000.0	36DY474F015CF2A	2.500 x 5.625 (64.0 x 143.0)	4.2	34.0
680 000.0	36DY684F015DF2A	3.000 x 5.625 (76.0 x 143.0)	4.1	38.4
25 WVDC at + 85 °C, SURGE = 30 V				
18 000.0	36DY183F025AM2A	1.375 x 2.625 (35.0 x 67.0)	25.0	7.12
22 000.0	36DY223F025AB2A	1.375 x 3.125 (35.0 x 79.0)	21.0	8.42
47 000.0	36DY473F025AF2A	1.375 x 5.625 (35.0 x 143.0)	12.6	14.0
33 000.0	36DY333F025BM2A	2.000 x 2.625 (51.0 x 67.0)	15.4	11.5
47 000.0	36DY473F025BB2A	2.000 x 3.125 (51.0 x 79.0)	12.3	13.8
100 000.0	36DY104F025BF2A	2.000 x 5.625 (51.0 x 143.0)	7.2	22.8
120 000.0	36DY124F025CC2A	2.500 x 4.125 (64.0 x 105.0)	6.7	23.8
220 000.0	36DY224F025DE2A	3.000 x 5.125 (76.0 x 130.0)	4.5	35.3
390 000.0	36DY394F025DJ2A	3.000 x 8.625 (76.0 x 219.0)	3.5	49.5
40 WVDC at + 85 °C, SURGE = 50 V				
4700.0	36DY472F040AN2A	1.375 x 1.625 (35.0 x 41.0)	59.0	3.89
10 000.0	36DY103F040AM2A	1.375 x 2.625 (35.0 x 67.0)	28.0	6.84
12 000.0	36DY123F040AB2A	1.375 x 3.125 (35.0 x 79.0)	23.0	8.10
15 000.0	36DY153F040AL2A	1.375 x 3.625 (35.0 x 92.0)	19.4	9.30
10 000.0	36DY103F040BY2A	2.000 x 1.875 (51.0 x 48.0)	30.0	7.40
27 000.0	36DY273F040BB2A	2.000 x 3.125 (51.0 x 79.0)	12.8	13.5
33 000.0	36DY333F040BL2A	2.000 x 3.625 (51.0 x 92.0)	10.9	15.5
39 000.0	36DY393F040BC2A	2.000 x 4.125 (51.0 x 105.0)	9.6	17.4
47 000.0	36DY473F040CB2A	2.500 x 3.125 (64.0 x 79.0)	9.1	18.4
100 000.0	36DY104F040DC2A	3.000 x 4.125 (76.0 x 105.0)	5.4	29.7
8200.0	36DY822F040AM2A	1.375 x 2.625 (35.0 x 67.0)	29.0	6.66
10 000.0	36DY103F040AB2A	1.375 x 3.125 (35.0 x 79.0)	24.0	7.79
15 000.0	36DY153F040AC2A	1.375 x 4.125 (35.0 x 105.0)	18.2	10.1

Aluminum Capacitors
+ 85 °C, Large Can

Vishay Sprague

ELECTRICAL DATA AND ORDERING INFORMATION				
CAPACITANCE (μF)	PART NUMBER	NOMINAL CASE SIZE D x L	MAX. ESR at 25 °C (mΩ) 120 Hz	MAX. RIPPLE at + 85 °C (A) 120 Hz
50 WVDC at + 85 °C, SURGE = 65 V				
5600.0	36DY562F050AA2A	1.375 x 2.125 (35.0 x 54.0)	40.0	5.25
8200.0	36DY822F050AM2A	1.375 x 2.625 (35.0 x 67.0)	29.0	6.66
10 000.0	36DY103F050AB2A	1.375 x 3.125 (35.0 x 79.0)	24.0	8.60
47 000.0	36DY473F050BF2A	2.000 x 5.625 (51.0 x 143.0)	7.7	22.1
100 000.0	36DY104F050DE2A	3.000 x 5.125 (76.0 x 130.0)	4.8	34.2
180 000.0	36DY184F050DJ2A	3.000 x 8.625 (76.0 x 219.0)	3.6	48.8
60 WVDC at + 85 °C, SURGE = 75 V				
2700.0	36DY272F060AN2A	1.375 x 1.625 (35.0 x 41.0)	69.0	3.62
4700.0	36DY472F060AA2A	1.375 x 2.125 (35.0 x 54.0)	42.0	5.10
8200.0	36DY822F060AB2A	1.375 x 3.125 (35.0 x 79.0)	25.0	7.72
10 000.0	36DY103F060AL2A	1.375 x 3.625 (35.0 x 92.0)	22.0	8.75
15 000.0	36DY153F060BB2A	2.000 x 3.125 (51.0 x 79.0)	13.9	13.0
22 000.0	36DY223F060BL2A	2.000 x 3.625 (51.0 x 92.0)	11.7	15.0
47 000.0	36DY473F060CD2A	2.500 x 4.625 (64.0 x 117.0)	6.6	25.1
100 000.0	36DY104F060DF2A	3.000 x 5.625 (76.0 x 143.0)	4.5	36.7
75 WVDC at + 85 °C, SURGE = 95 V				
1800.0	36DY182F075AN2A	1.375 x 1.625 (35.0 x 41.0)	104.0	2.95
3300.0	36DY332F075AA2A	1.375 x 2.125 (35.0 x 54.0)	62.0	4.19
5600.0	36DY562F075AB2A	1.375 x 3.125 (35.0 x 79.0)	36.0	6.45
6800.0	36DY682F075AL2A	1.375 x 3.625 (35.0 x 92.0)	30.0	7.50
10 000.0	36DY103F075AD2A	1.375 x 4.625 (35.0 x 117.0)	24.0	9.26
12 000.0	36DY123F075BB2A	2.000 x 3.125 (51.0 x 79.0)	18.8	11.1
18 000.0	36DY183F075BC2A	2.000 x 4.125 (51.0 x 105.0)	13.7	14.5
47 000.0	36DY473F075CF2A	2.500 x 5.625 (64.0 x 143.0)	6.7	26.9
47 000.0	36DY473F075DC2A	3.000 x 4.125 (76.0 x 105.0)	8.9	23.2
120 000.0	36DY124F075DJ2A	3.000 x 8.625 (76.0 x 219.0)	5.0	41.5
100 WVDC at + 85 °C, SURGE = 125 V				
1800.0	36DY182F100AM2A	1.375 x 2.625 (35.0 x 67.0)	56.0	4.82
4700.0	36DY472F100AC2A	1.375 x 4.125 (35.0 x 105.0)	32.0	7.68
4700.0	36DY472F100BM2A	2.000 x 2.625 (51.0 x 67.0)	30.0	8.29
10 000.0	36DY103F100BC2A	2.000 x 4.125 (51.0 x 105.0)	16.3	13.3
10 000.0	36DY103F100CB2A	2.500 x 3.125 (64.0 x 79.0)	14.8	14.5
18 000.0	36DY183F100DL2A	3.000 x 3.625 (76.0 x 92.0)	11.2	19.7
33 000.0	36DY333F100DE2A	3.000 x 5.125 (76.0 x 130.0)	7.9	26.7
150 WVDC at + 85 °C, SURGE = 175 V				
2700.0	36DY272F150AF2A	1.375 x 5.625 (35.0 x 143.0)	35.0	6.84
2200.0	36DY222F150BB2A	2.000 x 3.125 (51.0 x 79.0)	57.0	5.22
5600.0	36DY562F150BF2A	2.000 x 5.625 (51.0 x 143.0)	22.0	10.66
10 000.0	36DY103F150CF2A	2.500 x 5.625 (64.0 x 143.0)	12.0	16.43
10 000.0	36DY103F150DC2A	3.000 x 4.125 (76.0 x 105.0)	17.0	13.68
200 WVDC at + 85 °C, SURGE = 250 V				
1000.0	36DY102F200AB2A	1.375 x 3.125 (35.0 x 79.0)	84.0	1.5
1500.0	36DY152F200BM2A	2.000 x 2.625 (51.0 x 67.0)	72.0	4.36
2200.0	36DY222F200BL2A	2.000 x 3.625 (51.0 x 92.0)	49.0	5.97
2700.0	36DY272F200BC2A	2.000 x 4.125 (51.0 x 105.0)	40.0	6.95
3300.0	36DY332F200CB2A	2.500 x 3.125 (64.0 x 79.0)	32.0	8.03
4700.0	36DY472F200CC2A	2.500 x 4.125 (64.0 x 105.0)	22.0	10.73
10 000.0	36DY103F200DE2A	3.000 x 5.125 (76.0 x 130.0)	14.0	16.36

**ELECTRICAL DATA AND ORDERING INFORMATION**

CAPACITANCE (μ F)	PART NUMBER	NOMINAL CASE SIZE D x L	MAX. ESR at 25 °C ($m\Omega$) 120 Hz	MAX. RIPPLE at + 85 °C (A) 120 Hz
250 WVDC at + 85 °C, SURGE = 300 V				
560.0	36DY561F250AM2A	1.375 x 2.625 (35.0 x 67.0)	132.0	2.55
1000.0	36DY102F250AL2A	1.375 x 3.625 (35.0 x 92.0)	74.0	3.89
2700.0	36DY272F250BD2A	2.000 x 4.625 (51.0 x 117.0)	34.0	7.90
3300.0	36DY332F250BF2A	2.000 x 5.625 (51.0 x 143.0)	29.0	9.44
2700.0	36DY272F250CB2A	2.500 x 3.125 (64.0 x 79.0)	34.0	7.79
4700.0	36DY472F250DL2A	3.000 x 3.625 (76.0 x 92.0)	24.0	10.99
10 000.0	36DY103F250DF2A	3.000 x 5.625 (76.0 x 143.0)	11.0	19.14
350 WVDC at + 85 °C, SURGE = 400 V				
470.0	36DY471F350AB2A	1.375 x 3.125 (35.0 x 79.0)	272.0	1.91
1000.0	36DY102F350AF2A	1.375 x 5.625 (35.0 x 143.0)	128.0	3.58
1000.0	36DY102F350BL2A	2.000 x 3.625 (51.0 x 92.0)	136.0	3.58
1800.0	36DY182F350BF2A	2.000 x 5.625 (51.0 x 143.0)	76.0	5.73
3300.0	36DY332F350DC2A	3.000 x 4.125 (76.0 x 105.0)	44.0	8.50
4700.0	36DY472F350DE2A	3.000 x 5.125 (76.0 x 130.0)	31.0	10.99
400 WVDC at + 85 °C, SURGE = 450 V				
270.0	36DY271F400AM2A	1.375 x 2.625 (35.0 x 67.0)	429.0	1.41
680.0	36DY681F400AE2A	1.375 x 5.125 (35.0 x 130.0)	170.0	2.98
1000.0	36DY102F400BC2A	2.000 x 4.125 (51.0 x 105.0)	123.0	3.96
2200.0	36DY222F400CD2A	2.500 x 4.625 (64.0 x 117.0)	55.0	7.09
2700.0	36DY272F400DC2A	3.000 x 4.125 (76.0 x 105.0)	48.0	8.14
6800.0	36DY682F400DJ2A	3.000 x 8.625 (76.0 x 219.0)	19.0	17.36
450 WVDC at + 85 °C, SURGE = 525 V				
330.0	36DY331F450AB2A	1.375 x 3.125 (35.0 x 79.0)	317.0	1.77
680.0	36DY681F450AE2A	1.375 x 5.125 (35.0 x 130.0)	164.0	3.13
1000.0	36DY102F450BC2A	2.000 x 4.125 (51.0 x 105.0)	113.0	4.13
2700.0	36DY272F450CF2A	2.500 x 5.625 (64.0 x 143.0)	42.0	8.78
3300.0	36DY332F450DD2A	3.000 x 4.625 (64.0 x 117.0)	36.0	10.20
5600.0	36DY562F450DJ2A	3.000 x 8.625 (76.0 x 219.0)	21.0	16.51

Aluminum Capacitors Powerlytic[®], Large Can

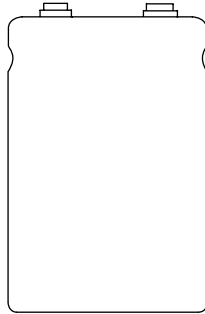


Fig.1 Component Outlines

FEATURES

- High capacitance per case size
- High ripple current
- Low leakage current
- Long shelf life and operating life
- Type 36D ratings recommended for replacement applications only. For new designs, see type 36DY.


**RoHS
COMPLIANT**

QUICK REFERENCE DATA	
DESCRIPTION	VALUE
Nominal case size Ø D x L in inches (mm)	1.453 x 2.250 (36.9 x 57.2) to 3.078 x 8.750 (78.2 x 222.3)
Operating temperature	- 40 °C to + 85 °C (36DX) - 40 °C to + 95 °C (36DE)
Rated capacitance range, C _R	190 µF to 50 000 µF
Tolerance on C _R	+ 75 %, - 10 % (10 WVDC to 100 WVDC) + 50 %, - 10 % (200 WVDC to 450 WVDC)
Rated voltage range, U _R	10 WVDC to 450 WVDC
Life validation test at 85 °C	1000 h: ΔCAP ± 15 % from initial measurement. ΔESR 1.5 x initial specified limit

DIMENSIONS in inches (millimeters)							
LARGE CAN CAPACITORS							
CASE CODE	NOMINAL		WITH INSULATING SLEEVE			TERMINAL SPACING M ± 0.016 (0.4)	TYPICAL WEIGHT (g)
	D ± 0.032 (0.8)	L ± 0.063 (1.6)	D (Max.)	L (Max.)	P TERMINAL H (Max.)		
AN	1.375 (35.0)	1.625 (41.0)	1.453 (36.9)	1.750 (44.5)	1.849 (47.0)	0.500 (12.7)	43.0
AY	1.375 (35.0)	1.875 (48.0)	1.453 (36.9)	2.000 (50.8)	1.099 (53.3)	0.500 (12.7)	54.0
AA	1.375 (35.0)	2.125 (54.0)	1.453 (36.9)	2.250 (57.2)	1.349 (59.7)	0.500 (12.7)	63.0
AM	1.375 (35.0)	2.625 (67.0)	1.453 (36.9)	2.750 (69.9)	1.849 (72.4)	0.500 (12.7)	82.0
AB	1.375 (35.0)	3.125 (79.0)	1.453 (36.9)	3.250 (82.6)	1.349 (85.1)	0.500 (12.7)	105.0
AL	1.375 (35.0)	3.625 (92.0)	1.453 (36.9)	3.750 (95.3)	1.849 (97.8)	0.500 (12.7)	122.0
AC	1.375 (35.0)	4.125 (105.0)	1.453 (36.9)	4.250 (108.0)	1.349 (110.5)	0.500 (12.7)	129.0
AD	1.375 (35.0)	4.625 (117.0)	1.453 (36.9)	4.750 (120.7)	1.849 (123.2)	0.500 (12.7)	162.0
AE	1.375 (35.0)	5.125 (130.0)	1.453 (36.9)	5.250 (133.4)	1.349 (125.9)	0.500 (12.7)	179.0
AF	1.375 (35.0)	5.625 (143.0)	1.453 (36.9)	5.750 (146.1)	1.849 (148.6)	0.500 (12.7)	201.0
EN	1.750 (44.0)	1.625 (41.0)	1.828 (46.4)	1.750 (44.5)	1.849 (47.0)	0.750 (19.1)	71.0
EY	1.750 (44.0)	1.875 (48.0)	1.828 (46.4)	2.000 (50.8)	2.099 (53.3)	0.750 (19.1)	88.0
EA	1.750 (44.0)	2.125 (54.0)	1.828 (46.4)	2.250 (57.2)	2.349 (59.7)	0.750 (19.1)	102.0
EM	1.750 (44.0)	2.625 (67.0)	1.828 (46.4)	2.750 (69.9)	2.849 (72.4)	0.750 (19.1)	133.0
EB	1.750 (44.0)	3.125 (79.0)	1.828 (46.4)	3.250 (82.6)	3.349 (85.1)	0.750 (19.1)	167.0
EL	1.750 (44.0)	3.625 (92.0)	1.828 (46.4)	3.750 (95.3)	3.849 (97.8)	0.750 (19.1)	198.0
EC	1.750 (44.0)	4.125 (105.0)	1.828 (46.4)	4.250 (108.0)	4.349 (110.5)	0.750 (19.1)	230.0
ED	1.750 (44.0)	4.625 (117.0)	1.828 (46.4)	4.750 (120.7)	4.849 (123.2)	0.750 (19.1)	252.0
EE	1.750 (44.0)	5.125 (130.0)	1.828 (46.4)	5.250 (133.4)	5.349 (135.9)	0.750 (19.1)	269.0
EF	1.750 (44.0)	5.625 (143.0)	1.828 (46.4)	5.750 (146.1)	5.849 (148.6)	0.750 (19.1)	318.0

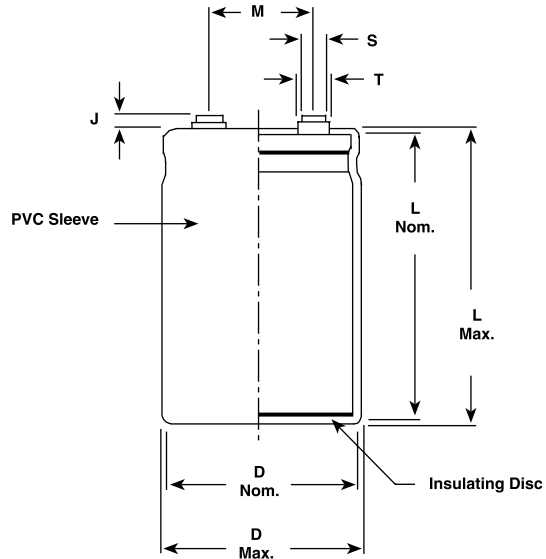
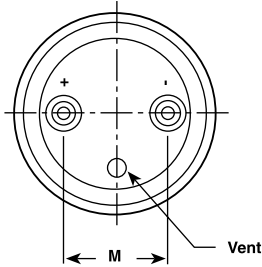


DIMENSIONS in inches (millimeters)							
LARGE CAN CAPACITORS							
CASE CODE	NOMINAL		WITH INSULATING SLEEVE			TERMINAL SPACING M ± 0.016 (0.4)	TYPICAL WEIGHT (g)
	D ± 0.032 (0.8)	L ± 0.063 (1.6)	D (Max.)	L (Max.)	P TERMINAL H (Max.)		
BY	2.000 (51.0)	1.875 (48.0)	2.078 (52.8)	2.000 (50.8)	2.099 (53.3)	0.875 (22.2)	113.0
BA	2.000 (51.0)	2.125 (54.0)	2.078 (52.8)	2.250 (57.2)	2.349 (59.7)	0.875 (22.2)	133.0
BM	2.000 (51.0)	2.625 (67.0)	2.078 (52.8)	2.750 (69.9)	2.849 (72.4)	0.875 (22.2)	176.0
BB	2.000 (51.0)	3.125 (79.0)	2.078 (52.8)	3.250 (82.6)	3.349 (85.1)	0.875 (22.2)	213.0
BL	2.000 (51.0)	3.625 (92.0)	2.078 (52.8)	3.750 (95.3)	3.849 (97.8)	0.875 (22.2)	261.0
BC	2.000 (51.0)	4.125 (105.0)	2.078 (52.8)	4.250 (108.0)	4.349 (110.5)	0.875 (22.2)	381.0
BD	2.000 (51.0)	4.625 (117.0)	2.078 (52.8)	4.750 (120.7)	4.849 (123.2)	0.875 (22.2)	326.0
BE	2.000 (51.0)	5.125 (130.0)	2.078 (52.8)	5.250 (133.4)	5.349 (135.9)	0.875 (22.2)	337.0
BF	2.000 (51.0)	5.625 (143.0)	2.078 (52.8)	5.750 (146.1)	5.849 (148.6)	0.875 (22.2)	408.0
CB	2.500 (64.0)	3.125 (79.0)	2.578 (65.5)	3.250 (82.6)	N/A	1.125 (28.6)	329.0
CL	2.500 (64.0)	3.625 (92.0)	2.578 (65.5)	3.750 (95.3)	N/A	1.125 (28.6)	400.0
CC	2.500 (64.0)	4.125 (105.0)	2.578 (65.5)	4.250 (108.0)	N/A	1.125 (28.6)	473.0
CD	2.500 (64.0)	4.625 (117.0)	2.578 (65.5)	4.750 (120.7)	N/A	1.125 (28.6)	562.0
CE	2.500 (64.0)	5.125 (130.0)	2.578 (65.5)	5.250 (133.4)	N/A	1.125 (28.6)	607.0
CF	2.500 (64.0)	5.625 (143.0)	2.578 (65.5)	5.750 (146.1)	N/A	1.125 (28.6)	675.0
DB	3.000 (76.0)	3.125 (79.0)	3.078 (78.2)	3.250 (82.6)	N/A	1.250 (31.8)	496.0
DL	3.000 (76.0)	3.625 (92.0)	3.078 (78.2)	3.750 (95.3)	N/A	1.250 (31.8)	598.0
DC	3.000 (76.0)	4.125 (105.0)	3.078 (78.2)	4.250 (108.0)	N/A	1.250 (31.8)	700.0
DD	3.000 (76.0)	4.625 (117.0)	3.078 (78.2)	4.750 (120.7)	N/A	1.250 (31.8)	802.0
DE	3.000 (76.0)	5.125 (130.0)	3.078 (78.2)	5.250 (133.4)	N/A	1.250 (31.8)	944.0
DF	3.000 (76.0)	5.625 (143.0)	3.078 (78.2)	5.750 (146.1)	N/A	1.250 (31.8)	1004.0
DJ	3.000 (76.0)	8.625 (219.0)	3.078 (78.2)	8.750 (222.3)	N/A	1.250 (31.8)	1403.0

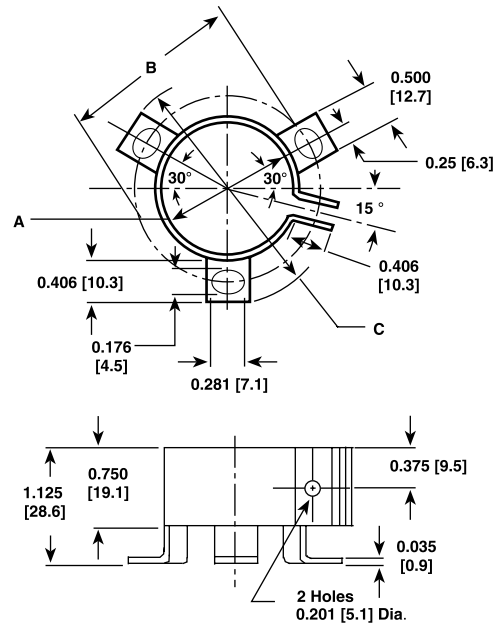
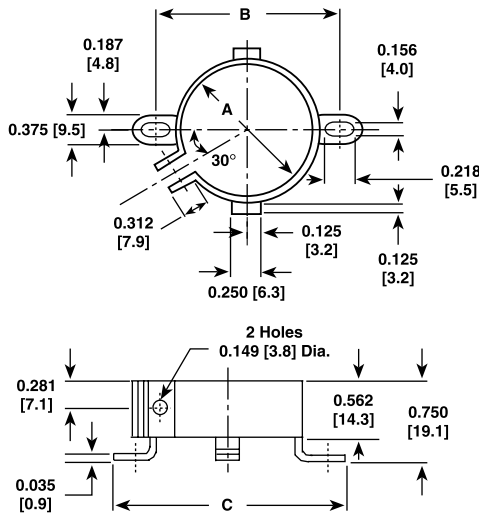
DIMENSIONS in inches (millimeters)						
BRACKETS (RoHS COMPLIANT)						
TYPE	PART NUMBER	A	B	C	FIGURE NUMBER	
2 Feet	1245860035A	1.375 (34.9)	1.781 (45.2)	2.218 (56.3)	1	
3 Feet	1245860036A	2.000 (50.8)	2.500 (63.5)	2.875 (73.0)	2	
3 Feet	1245860037A	2.500 (63.5)	3.000 (76.2)	3.375 (85.7)	2	
3 Feet	1245860038A	3.000 (76.2)	3.500 (88.9)	3.875 (98.4)	2	
SCREW INSERT TERMINAL DIMENSIONS						
TERMINAL CODE	THREAD	THREAD DEPTH	HEIGHT J ± 0.032 (0.81)	DIAMETER S ± 0.010 (0.25)	DIAMETER T ± 0.010 (0.25)	NOTES
A	10-32 NF-28	0.219 (5.6)	0.063 (1.6)	0.313 (8.0)	0.438 (11.1)	All cases codes
B	10-32 NF-28	0.375 (9.5)	0.250 (6.4)	0.313 (8.0)	0.438 (11.1)	All cases codes
D	1/4-28 NF-28	0.344 (8.7)	0.093 (2.4)	0.688 (17.5)	-	C and D dia. codes only

DIMENSIONS AND AVAILABLE FORMS

Screw Insert Terminals



Large Can Brackets



ORDERING EXAMPLE

Electrolytic capacitor 36DX series: 36DX 392 G 075 BB 2 A

DESCRIPTION	
CODE	EXPLANATION
36DX	Product type
392	Capacitance value (3900 μ F)
G	Tolerance (G = - 10 %/+ 75 %; F = -10 %/+ 50 %)
075	Voltage rating at 85 °C (75 V)
BB	Can size (see dimensions table)
2	PVC insulating sleeve
A	Terminal code (low insert 10-32 screw thread)

ELECTRICAL DATA (Original/improved ratings)		
CAPACITANCE (μ F)	CASE CODE	PART NUMBER
TYPE 36D ORIGINAL RATINGS		
25 WVDC at + 85 °C, SURGE = 30 V		
2700.0 ⁽¹⁾	AA	36D272G025AA2A
5500.0 ⁽¹⁾	AB	36D552G025AB2A
40 WVDC at + 85 °C, SURGE = 50 V		
5500.0 ⁽¹⁾	AC	36D552G040AC2A
8400.0 ⁽¹⁾	BB	36D842G040BB2A
50 WVDC at + 85 °C, SURGE = 650 V		
1300.0 ⁽¹⁾	AA	36D132G050AA2A
5200.0 ⁽¹⁾	AE	36D522G050AE2A
TYPE 36DE IMPROVED RATINGS		
25 WVDC at + 85 °C, SURGE = 30 V		
40 000.0 ⁽¹⁾	BB	36DE403G025BB2A
TYPE 36DE ORIGINAL RATINGS		
10 WVDC at + 85 °C, SURGE = 12 V		
23 000.0 ⁽¹⁾	AA	36DE233G010AA2A
40 WVDC at + 85 °C, SURGE = 50 V		
24 000.0 ⁽¹⁾	BB	36DE243G040BB2A
TYPE 36DX IMPROVED RATINGS		
200 WVDC at + 85 °C, SURGE = 250 V		
850.0 ⁽¹⁾	AC	36DX851F200AC2A
2000.0 ⁽¹⁾	BC	36DX202F200BC2A
2800.0 ⁽¹⁾	BC	36DX282F200BC2A
3400.0 ⁽¹⁾	CC	36DX342F200CC2A
7400.0 ⁽¹⁾	DF	36DX742F200DF2A
250 WVDC at + 85 °C, SURGE = 300 V		
500.0 ⁽¹⁾	AB	36DX501F250AB2A
350 WVDC at + 85 °C, SURGE = 400 V		
260.0 ⁽¹⁾	AB	36DX261F350AB2A
5100.0	DJ	36DX512F350DJ2A
450 WVDC at + 85 °C, SURGE = 525 V		
230.0 ⁽¹⁾	AC	36DX231F450AC2A
2000.0 ⁽¹⁾	DF	36DX202F450DF2A
TYPE 36DX ORIGINAL RATINGS		
15 WVDC at + 85 °C, SURGE = 18 V		
7500.0 ⁽¹⁾	AA	36DX752G015AA2A
15 000.0 ⁽¹⁾	AB	36DX153G015AB2A
22 000.0 ⁽¹⁾	AC	36DX223G015AC2A
34 000.0 ⁽¹⁾	AF	36DX343G015AF2A
50 000.0 ⁽¹⁾	BC	36DX503G015BC2A
25 WVDC at + 85 °C, SURGE = 30 V		
4500.0 ⁽¹⁾	AA	36DX452G025AA2A
9000.0 ⁽¹⁾	AB	36DX902G025AB2A
13 000.0 ⁽¹⁾	AC	36DX133G025AC2A
30 000.0 ⁽¹⁾	BC	36DX303G025BC2A
50 000.0 ⁽¹⁾	CC	36DX503G025CC2A



ELECTRICAL DATA (Original/improved ratings)		
CAPACITANCE (μF)	CASE CODE	PART NUMBER
30 WVDC at + 85 °C, SURGE = 40 V		
4000.0 ⁽¹⁾	AA	36DX402G030AA2A
8000.0 ⁽¹⁾	AB	36DX802G030AB2A
18 000.0 ⁽¹⁾	AF	36DX183G030AF2A
26 000.0	BC	36DX263G030BC2A
40 WVDC at + 85 °C, SURGE = 50 V		
2900.0 ⁽¹⁾	AA	36DX292G040AA2A
5800.0 ⁽¹⁾	AB	36DX582G040AB2A
8700.0 ⁽¹⁾	AC	36DX872G040AC2A
20 000.0 ⁽¹⁾	BC	36DX203G040BC2A
34 000.0 ⁽¹⁾	CC	36DX343G040CC2A
50 WVDC at + 85 °C, SURGE = 65 V		
2400.0 ⁽¹⁾	AA	36DX242G050AA2A
4800.0 ⁽¹⁾	AB	36DX482G050AB2A
7200.0 ⁽¹⁾	AC	36DX722G050AC2A
11 000.0	AF	36DX113G050AF2A
16 000.0 ⁽¹⁾	BC	36DX163G050BC2A
24 000.0 ⁽¹⁾	BF	36DX243G050BF2A
40 000.0 ⁽¹⁾	CF	36DX403G050CF2A
41 000.0 ⁽¹⁾	DC	36DX413G050DC2A
75 WVDC at + 85 °C, SURGE = 95 V		
1400.0 ⁽¹⁾	AA	36DX142G075AA2A
10 000.0 ⁽¹⁾	BC	36DX103G075BC2A
17 000.0 ⁽¹⁾	CC	36DX173G075CC2A

Note

⁽¹⁾ This is representative of normally stocked ratings. Many other ratings are available.

Check your nearest stocking distributor. Additional Part Numbers normally found in distribution inventory include:

36D103G075CC2A	36D231G013BB2A	36D902G050BC2A	36DX332F350DF2A
36D123G040BC2A	36D262G050AB2A	36DX103F250DJ2A	36DX352F450DJ2A
36D133G015AC2A	36D392G050AC2A	36DX172G100AB2A	36DX372F350DF2A
36D153G050CC2A	36D392G075BB2A	36DX203G025AF2A	36DX422G075AC2A
36D191F350AB2A	36D602G050BB2A	36DX312F450DJ2A	

Aluminum Capacitors + 85 °C and + 95 °C, Large Can

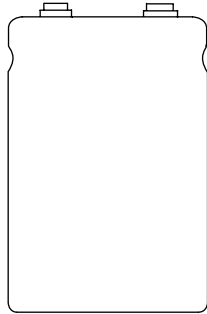


Fig.1 Component Outlines

FEATURES

- The industry standard for large can aluminum capacitors
- Ideal for high wattage power supplies and energy storage applications
- Largest capacitance available
- Highest voltage available
- Metric threads and stud mount versions included
- Replaces type 36DY



RoHS
COMPLIANT

QUICK REFERENCE DATA	
DESCRIPTION	VALUE
Nominal case size Ø D x L in inches (mm)	1.375 x 1.625 (35.0 x 41.2) to 3.000 x 8.675 (76.2 x 220.3)
Operating temperature	- 40 °C to + 95 °C: 6.3 WVDC to 100 WVDC; - 40 °C to + 85 °C; 125 WVDC to 500 WVDC
Rated capacitance range, C _R	100 µF to 2.2 F
Tolerance on C _R	- 10 % to 50 %
Rated voltage range, U _R	6.3 WVDC to 500 WVDC
Termination	Screw insert or solderable terminals
Life validation test at 85 °C	2000 h: ΔCAP ≤ 15 % from initial measurement ΔESR ≤ 1.5 x initial specified limit
Shelf life at 85 °C	500 h: ΔCAP ≤ 15 % from initial measurement ΔESR ≤ 1.2 x initial specified limit
DC leakage current 5 min charge time	$I = K\sqrt{CV}$ K = 4.0 at + 25 °C; 32.0 at + 85 °C I in µA, C in µF, V in Volts

RIPPLE CURRENT MULTIPLIERS			
TEMPERATURE			
AMBIENT TEMPERATURE	MULTIPLIERS		
+ 85 °C	1.0		
+ 75 °C	1.4		
+ 65 °C	1.7		
+ 55 °C and below	2.0		
FREQUENCY (Hz)			
RATED WVDC	120	400	1000 AND UP
0 to 50	1.0	1.05	1.10
51 to 100	1.0	1.10	1.15
150 to 300	1.0	1.15	1.25
301 to 500	1.0	1.20	1.30

DIMENSIONS in inches (millimeters)							
LARGE CAN CAPACITORS							
CASE CODE	NOMINAL		WITH INSULATING SLEEVE			TERMINAL SPACING M ± 0.016 (0.4)	TYPICAL WEIGHT (g)
	± 0.032 (0.8)	± 0.063 (1.6)	D (Max.)	L (Max.)	(P TERMINAL) H (Max.)		
AN	1.375 (35.0)	1.625 (41.0)	1.453 (36.9)	1.750 (44.5)	1.849 (47.0)	0.500 (12.7)	43.0
AY	1.375 (35.0)	1.875 (48.0)	1.453 (36.9)	2.000 (50.8)	1.099 (53.3)	0.500 (12.7)	54.0
AA	1.375 (35.0)	2.125 (54.0)	1.453 (36.9)	2.250 (57.2)	1.349 (59.7)	0.500 (12.7)	63.0
AM	1.375 (35.0)	2.625 (67.0)	1.453 (36.9)	2.750 (69.9)	1.849 (72.4)	0.500 (12.7)	82.0
AB	1.375 (35.0)	3.125 (79.0)	1.453 (36.9)	3.250 (82.6)	1.349 (85.1)	0.500 (12.7)	105.0
AL	1.375 (35.0)	3.625 (92.0)	1.453 (36.9)	3.750 (95.3)	1.849 (97.8)	0.500 (12.7)	122.0
AC	1.375 (35.0)	4.125 (105.0)	1.453 (36.9)	4.250 (108.0)	1.349 (110.5)	0.500 (12.7)	129.0

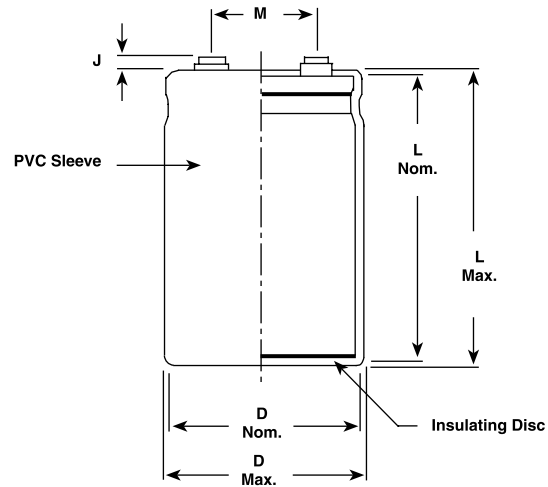
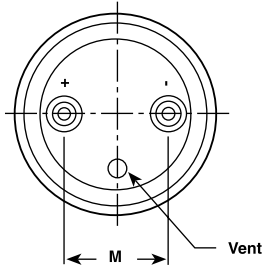


Aluminum Capacitors
+ 85 °C and + 95 °C, Large Can

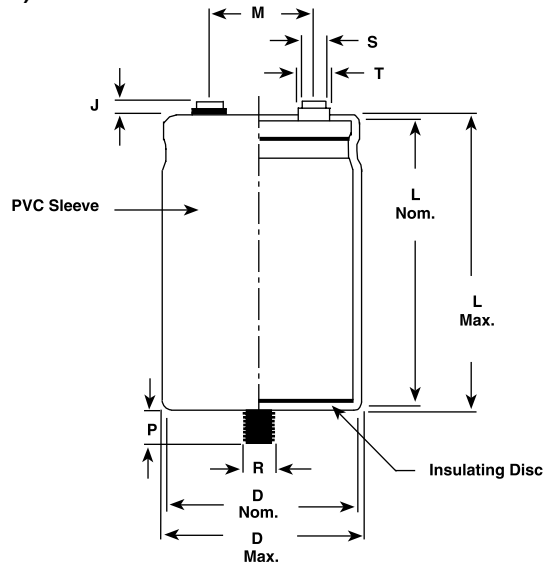
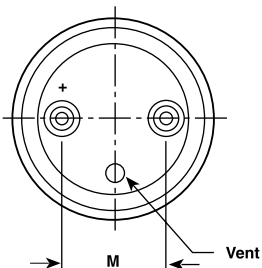
Vishay Sprague

DIMENSIONS in inches (millimeters)							
LARGE CAN CAPACITORS							
CASE CODE	NOMINAL		WITH INSULATING SLEEVE			TERMINAL SPACING M ± 0.016 (0.4)	TYPICAL WEIGHT (g)
	D ± 0.032 (0.8)	L ± 0.063 (1.6)	D (Max.)	L (Max.)	(P TERMINAL) H (Max.)		
AD	1.375 (35.0)	4.625 (117.0)	1.453 (36.9)	4.750 (120.7)	1.849 (123.2)	0.500 (12.7)	162.0
AE	1.375 (35.0)	5.125 (130.0)	1.453 (36.9)	5.250 (133.4)	1.349 (125.9)	0.500 (12.7)	179.0
AF	1.375 (35.0)	5.625 (143.0)	1.453 (36.9)	5.750 (146.1)	1.849 (148.6)	0.500 (12.7)	201.0
EN	1.750 (44.0)	1.625 (41.0)	1.828 (46.4)	1.750 (44.5)	1.849 (47.0)	0.750 (19.1)	71.0
EY	1.750 (44.0)	1.875 (48.0)	1.828 (46.4)	2.000 (50.8)	2.099 (53.3)	0.750 (19.1)	88.0
EA	1.750 (44.0)	2.125 (54.0)	1.828 (46.4)	2.250 (57.2)	2.349 (59.7)	0.750 (19.1)	102.0
EM	1.750 (44.0)	2.625 (67.0)	1.828 (46.4)	2.750 (69.9)	2.849 (72.4)	0.750 (19.1)	133.0
EB	1.750 (44.0)	3.125 (79.0)	1.828 (46.4)	3.250 (82.6)	3.349 (85.1)	0.750 (19.1)	167.0
EL	1.750 (44.0)	3.625 (92.0)	1.828 (46.4)	3.750 (95.3)	3.849 (97.8)	0.750 (19.1)	198.0
EC	1.750 (44.0)	4.125 (105.0)	1.828 (46.4)	4.250 (108.0)	4.349 (110.5)	0.750 (19.1)	230.0
ED	1.750 (44.0)	4.625 (117.0)	1.828 (46.4)	4.750 (120.7)	4.849 (123.2)	0.750 (19.1)	252.0
EE	1.750 (44.0)	5.125 (130.0)	1.828 (46.4)	5.250 (133.4)	5.349 (135.9)	0.750 (19.1)	269.0
EF	1.750 (44.0)	5.625 (143.0)	1.828 (46.4)	5.750 (146.1)	5.849 (148.6)	0.750 (19.1)	318.0
BY	2.000 (51.0)	1.875 (48.0)	2.078 (52.8)	2.000 (50.8)	2.099 (53.3)	0.875 (22.2)	113.0
BA	2.000 (51.0)	2.125 (54.0)	2.078 (52.8)	2.250 (57.2)	2.349 (59.7)	0.875 (22.2)	133.0
BM	2.000 (51.0)	2.625 (67.0)	2.078 (52.8)	2.750 (69.9)	2.849 (72.4)	0.875 (22.2)	176.0
BB	2.000 (51.0)	3.125 (79.0)	2.078 (52.8)	3.250 (82.6)	3.349 (85.1)	0.875 (22.2)	213.0
BL	2.000 (51.0)	3.625 (92.0)	2.078 (52.8)	3.750 (95.3)	3.849 (97.8)	0.875 (22.2)	261.0
BC	2.000 (51.0)	4.125 (105.0)	2.078 (52.8)	4.250 (108.0)	4.349 (110.5)	0.875 (22.2)	381.0
BD	2.000 (51.0)	4.625 (117.0)	2.078 (52.8)	4.750 (120.7)	4.849 (123.2)	0.875 (22.2)	326.0
BE	2.000 (51.0)	5.125 (130.0)	2.078 (52.8)	5.250 (133.4)	5.349 (135.9)	0.875 (22.2)	337.0
BF	2.000 (51.0)	5.625 (143.0)	2.078 (52.8)	5.750 (146.1)	5.849 (148.6)	0.875 (22.2)	408.0
CB	2.500 (64.0)	3.125 (79.0)	2.578 (65.5)	3.250 (82.6)	N/A	1.125 (28.6)	329.0
CL	2.500 (64.0)	3.625 (92.0)	2.578 (65.5)	3.750 (95.3)	N/A	1.125 (28.6)	400.0
CC	2.500 (64.0)	4.125 (105.0)	2.578 (65.5)	4.250 (108.0)	N/A	1.125 (28.6)	473.0
CD	2.500 (64.0)	4.625 (117.0)	2.578 (65.5)	4.750 (120.7)	N/A	1.125 (28.6)	562.0
CE	2.500 (64.0)	5.125 (130.0)	2.578 (65.5)	5.250 (133.4)	N/A	1.125 (28.6)	607.0
CF	2.500 (64.0)	5.625 (143.0)	2.578 (65.5)	5.750 (146.1)	N/A	1.125 (28.6)	675.0
DB	3.000 (76.0)	3.125 (79.0)	3.078 (78.2)	3.250 (82.6)	N/A	1.250 (31.8)	496.0
DL	3.000 (76.0)	3.625 (92.0)	3.078 (78.2)	3.750 (95.3)	N/A	1.250 (31.8)	598.0
DC	3.000 (76.0)	4.125 (105.0)	3.078 (78.2)	4.250 (108.0)	N/A	1.250 (31.8)	700.0
DD	3.000 (76.0)	4.625 (117.0)	3.078 (78.2)	4.750 (120.7)	N/A	1.250 (31.8)	802.0
DE	3.000 (76.0)	5.125 (130.0)	3.078 (78.2)	5.250 (133.4)	N/A	1.250 (31.8)	944.0
DF	3.000 (76.0)	5.625 (143.0)	3.078 (78.2)	5.750 (146.1)	N/A	1.250 (31.8)	1004.0
DJ	3.000 (76.0)	8.625 (219.0)	3.078 (78.2)	8.750 (222.3)	N/A	1.250 (31.8)	1403.0

DIMENSIONS AND AVAILABLE FORMS



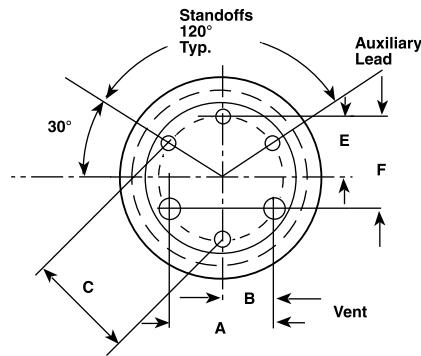
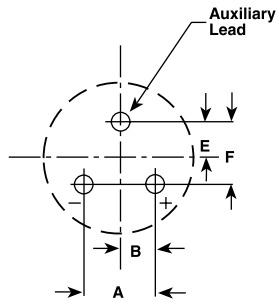
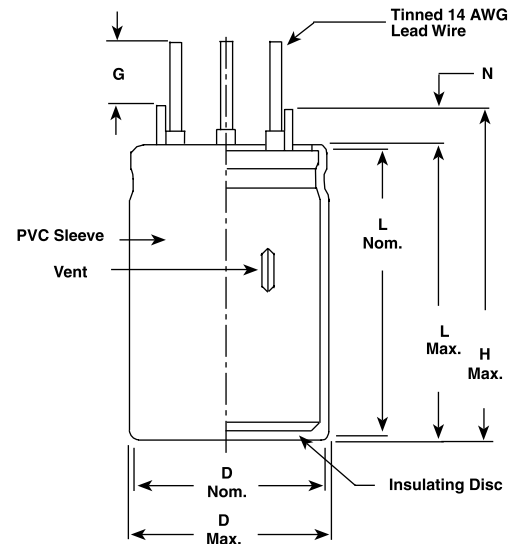
Stud Mount Option for Large Can Capacitors (Special Order)



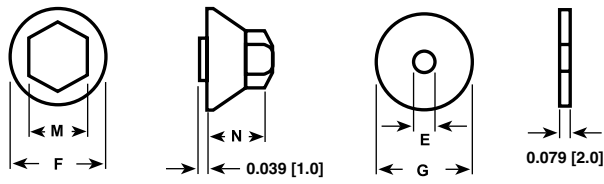
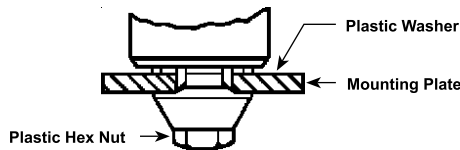
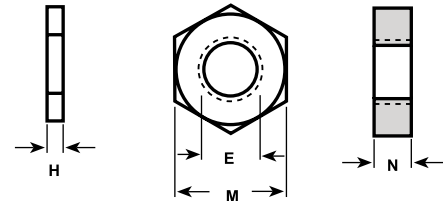
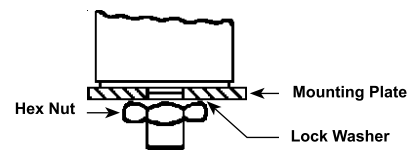
Note

• Not available on "DJ" case code, E diameters and "P" terminal option

DIMENSIONS in inches (millimeters)						
STUD						
CASE DIAMETER		R THREAD		HEIGHT P ± 0.039 (1.0)		
A		M8		0.472 (12.0)		
B, C, D		M12		0.630 (16.0)		
E		N/A		N/A		
TERMINAL CODE	THREAD	THREAD DEPTH	HEIGHT J ± 0.032 (0.8)	DIAMETER S ± 0.010 (0.25)	DIAMETER T ± 0.010 (0.25)	NOTES
A	10-32 NF-28	0.219 (5.6)	0.063 (1.6)	0.313 (8.0)	0.438 (11.1)	All sizes
B	10-32 NF-28	0.375 (9.5)	0.250 (6.4)	0.313 (8.0)	0.438 (11.1)	All sizes
D	1/4-28 NF-28	0.344 (8.7)	0.093 (2.4)	0.688 (17.5)	-	C and D dia. codes only
I	M5	0.375 (9.5)	0.250 (6.4)	0.313 (8.0)	-	Type 602D, 622D only
N	M5	0.219 (5.6)	0.063 (1.6)	0.313 (8.0)	0.438 (11.1)	Type 36D only
T	M5	0.375(9.5)	0.250 (6.4)	0.313 (8.0)	0.438 (11.1)	Type 36D only

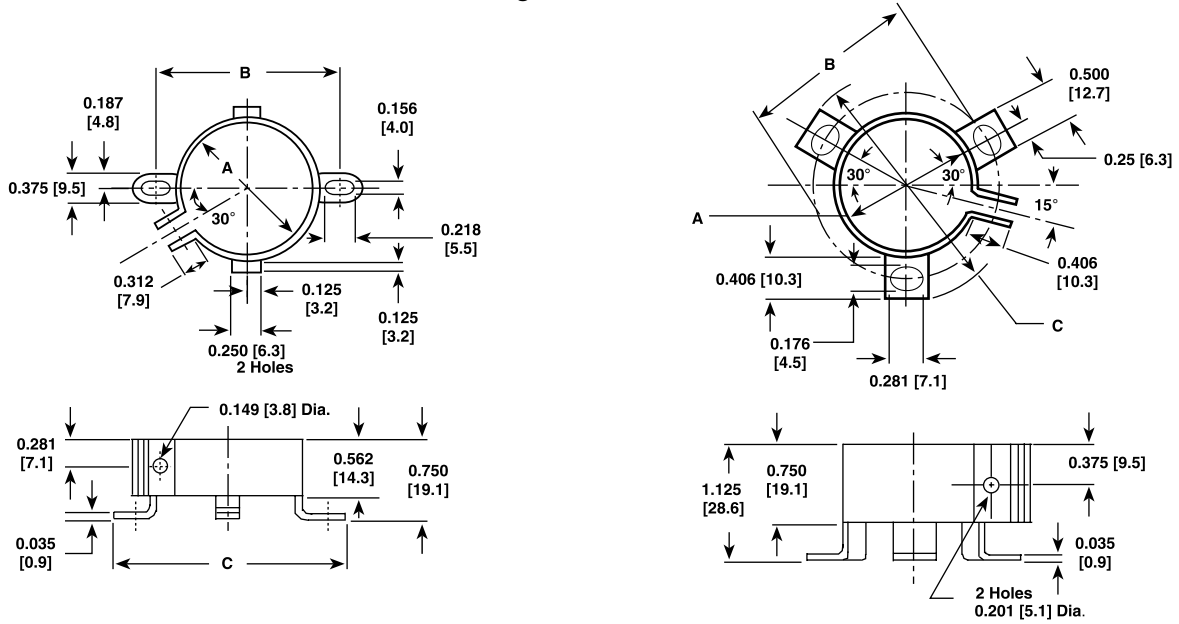
**Large Can Circuit Board Layout
(Bottom View)**

Circuit Board Mount "P" Terminal Dimensions


DIMENSIONS in inches (millimeters)						
BOARD						
NOMINAL CASE DIAMETER	A ± 0.032 (0.8)	B ± 0.032 (0.8)	C ± 0.032 (0.8)	E ± 0.032 (0.8)	F ± 0.032 (0.8)	G ± 0.020 (0.5)
1.375 (35.0)	0.500 (12.7)	0.250 (6.4)	0.937 (23.8)	0.375 (9.5)	0.550 (14.0)	0.312 (7.9)
1.750 (44.0)	0.700 (17.8)	0.350 (8.9)	1.350 (31.8)	0.525 (13.3)	0.900 (22.9)	0.312 (7.9)
2.000 (51.0)	0.800 (20.3)	0.400 (10.2)	1.400 (38.10)	0.575 (14.6)	1.000 (25.4)	0.312 (7.9)

Large Can Mounting Kits (Insulated)

Large Can Mounting Kits (Uninsulated)


DIMENSIONS in inches (millimeters)						
MOUNTING KITS						
TYPE	PART NUMBER	E	F	G	H	M
Insulated M8	50-8	0.331 (8.4)	1.0 (25.0)	1.0 (25.0)	-	0.669 (17.0)
Uninsulated M8	50-8A	0.331 (8.4)	-	0.551 (14.0)	0.31 (0.8)	0.512 (13.0)
Insulated M12	50-8B	0.512 (13.0)	1.181 (30.0)	1.0 (25.0)	-	0.748 (19.0)
Uninsulated M12	50-8C	0.512 (13.0)	-	0.807 (20.5)	0.38 (1.0)	0.748 (19.0)

Large Can Brackets



DIMENSIONS in inches (millimeters)					
BRACKETS (RoHS COMPLIANT)					
TYPE	PART NUMBER	A	B	C	FIGURE NUMBER
2 Feet	1245860035A	1.375 (35.0)	1.781 (45.0)	2.218 (56.3)	1
3 Feet	1245860036A	2.000 (51.0)	2.500 (64.0)	2.875 (73.0)	2
3 Feet	1245860037A	2.500 (64.0)	3.000 (76.0)	3.375 (85.7)	2
3 Feet	1245860038A	3.000 (76.0)	3.500 (88.9)	3.875 (98.4)	2

ORDERING EXAMPLE

Electrolytic capacitor 36DA series: 36DA 183 F 016 AN 2 A

DESCRIPTION	
CODE	EXPLANATION
36DA	Product type
183	Capacitance value (18 000 µF)
F	Tolerance (G = - 10 %/+ 75 %; F = - 10 %/+ 50 %)
016	Voltage rating at 85 °C (16 V)
AN	Can size (see dimensions table)
2	PVC insulating sleeve
A	Terminal code (low insert 10-32 screw thread)

**Aluminum Capacitors
+ 85 °C and + 95 °C, Large Can**

Vishay Sprague

ELECTRICAL DATA AND ORDERING INFORMATION				
CAPACITANCE (μF)	PART NUMBER	NOMINAL CASE SIZE D x L	MAX. ESR at 25 °C (mΩ) 120 Hz	MAX. RIPPLE at + 85 °C (A) 120 Hz
16 WVDC at + 85 °C, SURGE = 8 V				
18 000.0	36DA183F016AN2A	1.375 x 1.625 (35.0 x 41.0)	47.7	4.30
25 WVDC at + 85 °C, SURGE = 30 V				
8200.0	36DA822F025AN2A	1.375 x 1.625 (35.0 x 41.0)	51.5	4.10
12 000.0	36DA123F025AA2A	1.375 x 2.125 (35.0 x 54.0)	32.6	5.70
39 000.0	36DA393F025BM2A	2.000 x 2.625 (51.0 x 67.0)	13.7	12.2
50 WVDC at + 85 °C, SURGE = 65 V				
6800.0	36DA682F050AA2A	1.375 x 2.125 (35.0 x 54.0)	40.0	5.20
27 000.0	36DA273F050BB2A	2.000 x 3.125 (51.0 x 79.0)	13.3	13.20
47 000.0	36DA473F050CB2A	2.500 x 3.125 (64.0 x 79.0)	9.5	18.10
63 WVDC at + 85 °C, SURGE = 79 V				
2700.0	36DA272F063AN2A	1.375 x 1.625 (35.0 x 41.0)	69.0	3.62
160 WVDC at + 85 °C, SURGE = 200 V				
4700.0	36DA472F160BL2A	2.000 x 3.625 (51.0 x 92.0)	54.7	5.60
200 WVDC at + 85 °C, SURGE = 250 V				
1500.0	36DA152F200AB2A	1.375 x 3.125 (35.0 x 79.0)	84.0	3.43
2200.0	36DA222F200BM2A	2.000 x 2.675 (51.0 x 67.0)	72.0	4.36
8200.0	36DA822F200DL2A	3.000 x 3.625 (76.0 x 92.0)	20.0	12.04
250 WVDC at + 85 °C, SURGE = 300 V				
560.0	36DA561F250AA2A	1.375 x 2.125 (35.0 x 54.0)	158.0	2.15
350 WVDC at + 85 °C, SURGE = 400 V				
270.0	36DA271F350AA2A	1.375 x 2.125 (35.0 x 54.0)	590.6	1.12
470.0	36DA471F350AM2A	1.375 x 2.625 (35.0 x 41.0)	388.0	1.49
3300.0	36DA332F350CD2A	2.500 x 4.625 (64.0 x 117.0)	50.0	7.44
5600.0	36DA562F350DD2A	3.000 x 4.625 (76.0 x 117.0)	37.0	9.68
400 WVDC at + 85 °C, SURGE = 450 V				
1200.0	36DA122F400BL2A	2.000 x 3.625 (51.0 x 92.0)	150.0	3.41
450 WVDC at + 85 °C, SURGE = 525 V				
1200.0	36DA122F450BC2A	2.000 x 4.125 (51.0 x 105.0)	113.0	4.13
2200.0	36DA222F450CC2A	2.500 x 4.125 (64.0 x 105.0)	62.0	6.39



Standard Series Values in a Decade for Resistance and Capacitances

E3 TO E192																
ACCORDING TO IEC 60063																
E192	E96	E48	E192	E96	E48	E192	E96	E48	E192	E96	E48		E24	E12	E6	E3
100	100	100	178	178	178	316	316	316	562	562	562		10	10	10	10
101			180			320			569				11			
102	102		182	182		324	324		576	576			12	12		
104			184			328			583				13			
105	105	105	187	187	187	332	332	332	590	590	590		15	15	15	
106			189			336			597				16			
107	107		191	191		340	340		604	604			18	18		
109			193			344			612				20			
110	110	110	196	196	196	348	348	348	619	619	619		22	22	22	22
111			198			352			626				24			
113	113		200	200		357	357		634	634			27	27		
114			203			361			642				30			
115	115	115	205	205	205	365	365	365	649	649	649		33	33	33	
117			208			370			657				36			
118	118		210	210		374	374		665	665			39	39		
120			213			379			673				43			
121	121	121	215	215	215	383	383	383	681	681	681		47	47	47	47
123			218			388			690				51			
124	124		221	221		392	392		698	698			56	56		
126			223			397			706				62			
127	127	127	226	226	226	402	402	402	715	715	715		68	68	68	
129			229			407			723				75			
130	130		232	232		412	412		732	732			82	82		
132			234			417			741				91			
133	133	133	237	237	237	422	422	422	750	750	750					
135			240			427			759							
137	137		243	243		432	432		768	768						
138			246			437			777							
140	140	140	249	249	249	442	442	442	787	787	787					
142			252			448			796							
143	143		255	255		453	453		806	806						
145			258			459			816							
147	147	147	261	261	261	464	464	464	825	825	825					
149			264			470			835							
150	150		267	267		475	475		845	845						
152			271			481			856							
154	154	154	274	274	274	487	487	487	866	866	866					
156			277			493			876							
158	158		280	280		499	499		887	887						
160			284			505			898							
162	162	162	287	287	287	511	511	511	909	909	909					
164			291			517			920							
165	165		294	294		523	523		931	931						
167			298			530			942							
169	169	169	301	301	301	536	536	536	953	953	953					
172			305			542			965							
174	174		309	309		549	549		976	976						
176			312			556			988							

ONLINE INFORMATION

For product information and a current list of sales offices,
representatives and distributors, visit our website:

www.vishay.com

WORLDWIDE SALES CONTACTS

THE AMERICAS

UNITED STATES

VISHAY AMERICAS
ONE GREENWICH PLACE
SHELTON, CT 06484
UNITED STATES
PH: +1-402-563-6866
FAX: +1-402-563-6296

ASIA

SINGAPORE

VISHAY INTERTECHNOLOGY
ASIA PTE LTD.
25 TAMPINES STREET 92
KEPPEL BUILDING #02-00
SINGAPORE 528877
PH: +65-6788-6668
FAX: +65-6788-0988

P.R. CHINA

VISHAY TRADING (SHANGHAI) CO., LTD.
15D, SUN TONG INFOPORT PLAZA
55 HUAI HAI WEST ROAD
SHANGHAI 200030
P.R. CHINA
PH: +86-21-5258-5000
FAX: +86-21-5258-7979

JAPAN

VISHAY JAPAN CO., LTD.
MG IKENOHATA BLDG. 4F
1-2-18, IKENOHATA
TAITO-KU
TOKYO 110-0008
JAPAN
PH: +81-3-5832-6210
FAX: +81-3-5832-6260

EUROPE

GERMANY

VISHAY EUROPE SALES GMBH
GEHEIMRAT-ROSENTHAL-STR. 100
95100 SELB
GERMANY
PH: +49-9287-71-0
FAX: +49-9287-70435

FRANCE

VISHAY S.A.
199, BLVD DE LA MADELEINE
06003 NICE, CEDEX 1
FRANCE
PH: +33-4-9337-2920
FAX: +33-4-9337-2997

UNITED KINGDOM

VISHAY LTD.
PALLION INDUSTRIAL ESTATE
SUNDERLAND SR4 6SU
UNITED KINGDOM
PH: +44-191-514-4155
FAX: +44-191-567-8262

One of the World's Largest Manufacturers of
Discrete Semiconductors and Passive Components



World Headquarters

Vishay Intertechnology, Inc.
63 Lancaster Avenue
Malvern, PA 19355-2143
United States

One of the World's Largest Manufacturers of
Discrete Semiconductors and Passive Components

© Copyright 2008 Vishay Intertechnology, Inc.
® Registered trademarks of Vishay Intertechnology, Inc.
All rights reserved. Printed in Germany.
Specifications subject to change without notice.

www.vishay.com

VSE-DB0078-0810